

SL-015C Manual Focus Laser Cutting Head Operation Manual

Version: 2019.03 3rd Version
Author: Document Department
Weihong Corporation, All Rights Reserved

Contents

| | |
|--|----|
| 1. Product Overview..... | 3 |
| 1.1. Structural Diagram | 3 |
| 1.2. Main Technical Parameters..... | 4 |
| 2. Installation | 4 |
| 2.1. Check before Installation | 5 |
| 2.2. Install the Fiber Connector..... | 5 |
| 2.3. Install the Cutting Head to Z-axis..... | 8 |
| 2.4. Connect Cooling Water and Gas Pipes | 9 |
| 2.5. Install the Height Sensing Unit..... | 10 |
| 3. Commissioning..... | 10 |
| 3.1. Prepare before Commissioning..... | 10 |
| 3.2. Check the Laser Spot for Centering..... | 11 |
| 3.3. Check the Cutting Head for Verticality | 12 |
| 3.4. Test the Follow-up System | 13 |
| 3.5. Adjust the Zero Focal Position | 14 |
| 4. Maintenance | 15 |
| 4.1. Precautions..... | 15 |
| 4.2. Replacement and Maintenance of Wearing Parts | 16 |
| 5. Frequently Asked Questions (FAQs)..... | 17 |
| 5.1. Kerf Exists Adhering Slag or It Is Not Cut Thoroughly. | 17 |
| 5.2. One Side of the Kerf Exists Adhering Slag. | 18 |

| | |
|--|----|
| 5.3. Kerf is Too Large..... | 18 |
| 5.4. Temperature of the Cutting Head Rises..... | 18 |
| 5.5. The Center of the Orifice Cannot Detect Laser Emitting..... | 19 |
| 5.6. There is No Trace on the Surface of the Sheet in Marking..... | 19 |

SL Series Cutting Heads are independently developed by **WEIHONG Company** (stock code: 300508), and include the following models:

- [SL-015C](#)
- [SL-030A](#)
- [SL-060A](#)

Model naming rule: Short name + Power + Focusing mode + Version:

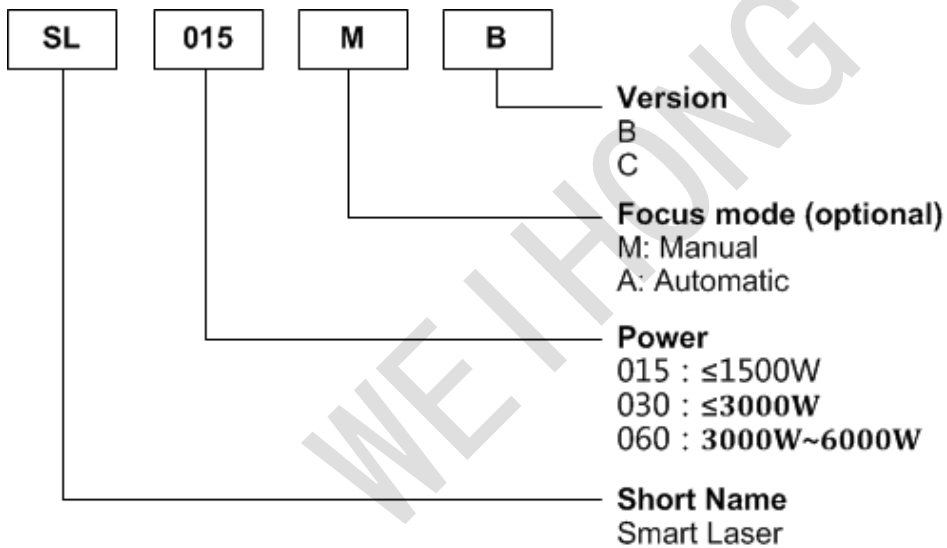

This manual is intended for operators / manufacturers. It mainly includes the following:

- [Product Overview](#)
- [Installation](#)
- [Commissioning](#)
- [Maintenance](#)
- [Frequently Asked Questions\(FAQs\)](#)

1. Product Overview

SL-015C Manual Focus Laser Cutting Head (Hereinafter referred to as **SL-015C**) is a cutting head for laser cutting machine tools with cutting power $\leq 1500\text{W}$. And it owns the following characteristics:

- Equipped with a detection system for full closed-loop focal position to monitor the change of focal position in real time.
- Simple and elegant appearance with the overall multi-level seal.
- Better stability with our **NcEditor V12 Laser Cutting Control System**.

1.1. Structural Diagram

The structural diagram of **SL-015C** is as follows:

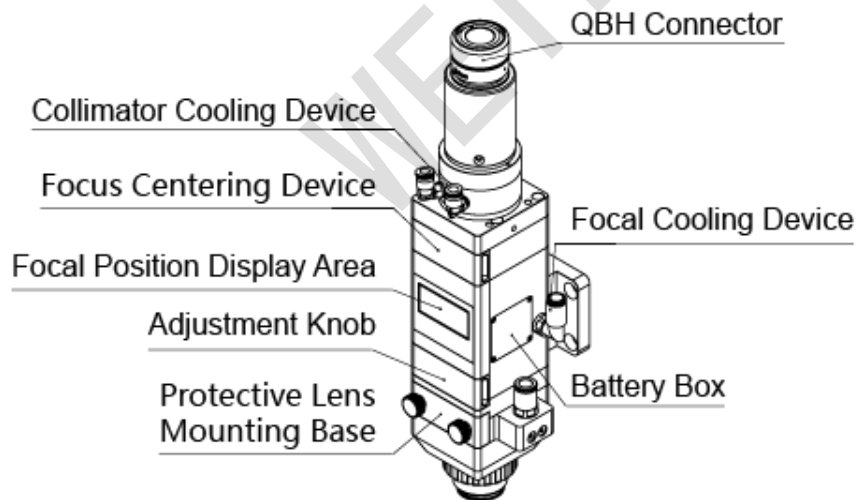

Note: Unauthorized disassembling of this product is PROHIBITED, except for wearing parts.

1.2. Main Technical Parameters

Main technical parameters of **SL-015C** are as follows:

- Product name: SL-015C Manual Focus Laser Cutting Head
- Product model: SL-015C
- Dimension: 98mm*90mm*343mm
- Type of fiber adapter: QBH
- Wavelength range: 1030nm~1060nm
- Power range: ≤1500W
- Clear aperture: 28mm
- Collimator focal length: 100mm
- Focal length: 125mm
- Adjustment range of focal length: -7mm ~ +7mm
- Adjustment precision of focal length: 0.01mm
- Adjustment precision of centering: 0.02mm
- Specification of focal protective lens: φ25.4mm*4mm
- Bearing of protective lens: ≤20bar
- Diameter of laser spot: 60μm ~ 200μm
- Mass: 2.5kg

2. Installation

The installation should be done by professional personnel according to the dimensional drawing and mounting method offered by us.

Before installation, checking is required. Please refer to [Check before Installation](#) for details.

The installation includes the following operations in order:

1. [Install the fiber connector.](#)
2. [Install the cutting head to Z-axis.](#)
3. [Connect the cooling water and gas pipes.](#)
4. [Install the height sensing unit.](#)

2.1. Check before Installation

This operation is used to get everything prepared before installation.

Before installation, check the following:

1. Open the product package, and check whether the model is what you have ordered and all accessories are included.

Please refer to *Packing List* for details.

2. Check whether the power range specified on the nameplate and the product certification matches with the power of laser device.
3. According to the following dimensional drawing, check whether the cutting head interferes with other parts of the machine tool and whether its travel setting meets that of the machine tool:

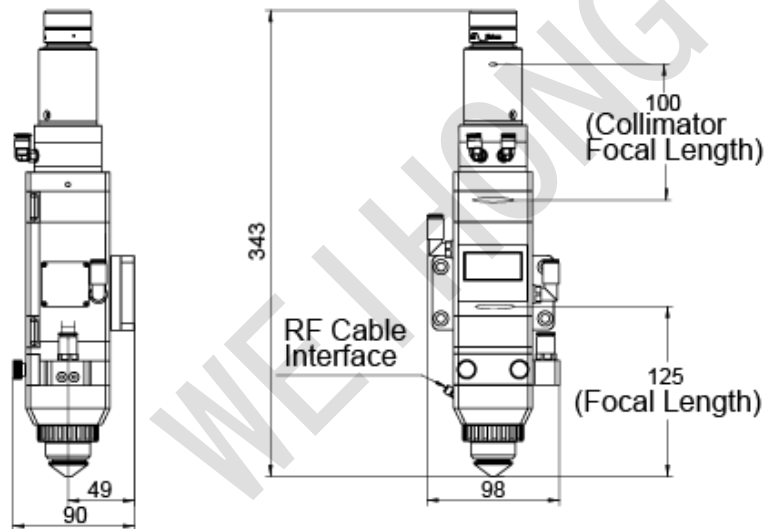

2.2. Install the Fiber Connector

This operation is used to lock the fiber connector.

The schematic diagram of the fiber connector is as follows:

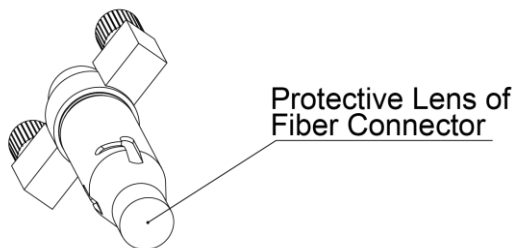

Before installing the fiber connector, cleaning is required:

- For how to clean it, refer to [Cleaning Steps](#) for details.
- For how to install it, refer to [Installing Steps](#) for details.

During cleaning and installing it, you need to follow the following requirements:

- A dust-free environment is required.
- Used tools and materials should not touch the surface of the fiber connector or inner surface of its interface.
- Protective lens of the fiber connector should keep dust-free.

2.2.1. Cleaning Steps

Before cleaning the fiber connector, prepare the following tools and materials:

- Several cleaning rods
- Several pieces of dust-free clothes
- A small amount of ethanol (alcohol) or acetone
- A pair of dust-free gloves
- A mask

To clean the fiber connector, do the following:

1. Clean your hands, put on dust-free gloves after drying your hands, and wear a mask.
2. Dip a piece of dust-free cloth in alcohol, and wipe the fiber optic cap and fiber connector needed to hold with the cloth.
3. Take off the fiber optic cap, and check the surface of the fiber connector for dust, mainly check the joint between the fiber optic cap and the fiber connector:
 - If no dust exists, [start installing the fiber connector](#).
 - If dust exists, proceed to next step.
4. **Optional:** Wipe the head, drive the dust into the tail, and wipe it in the tail with a piece of dust-free cloth.

Note: During the wiping process, dust-free cloth or cleaning rod cannot dip in too much alcohol to avoid water spot on the surface.

After the volatilization of liquid, install the fiber connector.

Warning: For fiber connectors without protective lens, wiping the position of the protective lens is PROHIBITED.

2.2.2. Installing Steps

To install the fiber connector, do the following:

1. Observe whether the marks of the QBH connector are in the same direction.

If not, rotate the QBH connector and keep the two marks in a straight line:

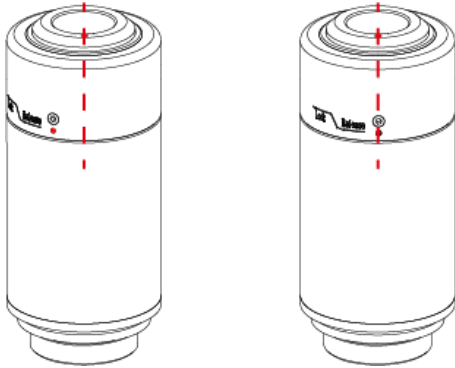

2. Horizontally place the cutting head and the fiber connector:

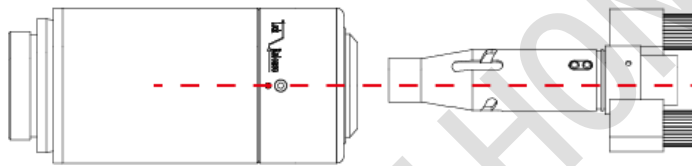

3. Align marks of the fiber connector and the QBH connector:

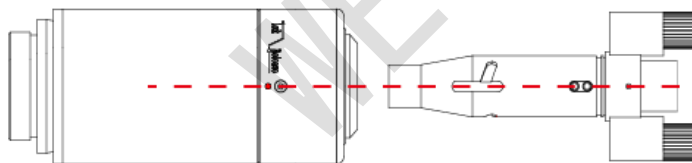

4. Gradually insert the fiber connector into the QBH connector:

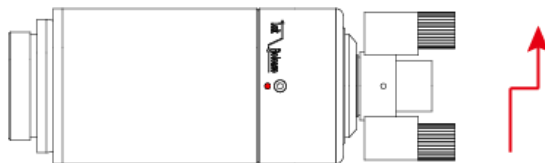

5. According to the marking direction of the QBH connector, lock the fiber connector by locking both ends.

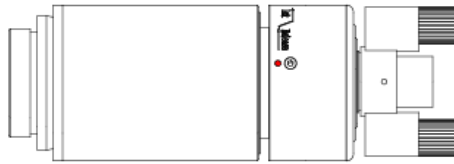

6. **Optional:** To further isolate dust, put a rustproof rubber sleeve between the fiber connector and QBH connector.

2.3. Install the Cutting Head to Z-axis

This operation is used to install the cutting head to Z-axis on the machine tool.

To install the cutting head to Z-axis on the machine tool, design the size and position of the mounting screw holes on the machine tool according the following mounting dimension:

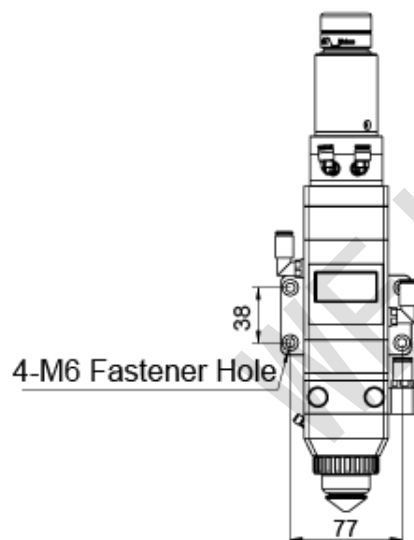

2.4. Connect Cooling Water and Gas Pipes

This operation is used to well connect cooling water pipes of different modules in series and the gas pipes in the cutting head, so as to avoid leakage.

To connect cooling water pipes and gas pipes, do the following:

1. Connect cooling water pipes of different modules in series according to the following schematic diagram:

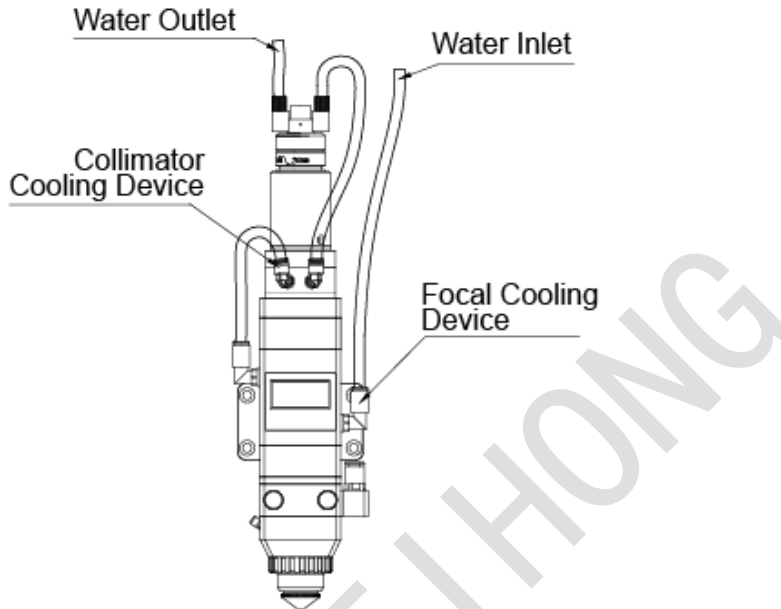

2. Turn on cooling water, and observe the flow to ensure no leakage at the seams.
3. Firmly install the gas pipe in the cutting head.
4. Spray bubbles at the joints of gas pipe and seams of the nozzle, and enable **Blow** function to observe whether there are bubbles at the joints and seams.

Note: When protective lens is not put into its mounting base or the cutting head is not inserted into the mounting base, **Blow** function is PROHIBITED!

2.5. Install the Height Sensing Unit

This operation is used to install the height sensing unit to the cutting head.

Install the height sensing unit according to the following schematic diagram:

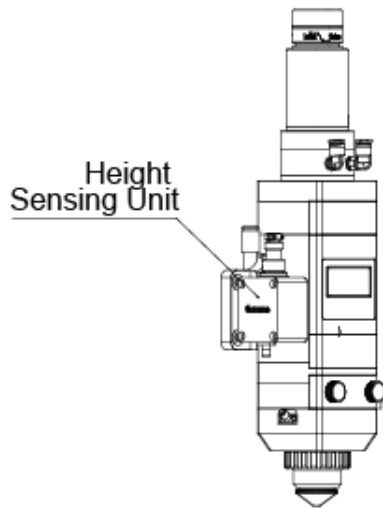

3. Commissioning

The commissioning should be done by professional personnel.

Before commissioning, preparing is required. Please refer to [Prepare before Commissioning](#) for details.

The commissioning includes the following operations in order:

1. [Check the laser spot for centering.](#)
2. [Check the cutting head for verticality.](#)
3. [Test the follow-up system.](#)
4. [Adjust the zero focal position.](#)

3.1. Prepare before Commissioning

This operation is used to prepare tools and materials used for commissioning.

Before doing commissioning, prepare the following tools and materials:

- Related laser cutting head
- Scotch tape
- Multimeter
- 1mm stainless steel sheet
- 0.5mm deformed sheet
- Height sensing unit

- A set of socket head wrench
- A machine tool with our laser cutting CNC system

3.2. Check the Laser Spot for Centering

This operation is used to check whether the laser spot is in the center of the orifice, and adjust it to the center if not.

To check the laser spot for centering, do the following:

1. Stick a piece of scotch tape on the nozzle of the cutting head.
2. Enable **Burst** function of the laser device to break it down.

Note: Please ensure **Shutter** is enabled before enabling **Burst** and **Laser** functions, and avoid being burned during using these functions.

3. Gradually tear the scotch tape laterally.
4. Observe the position relation between the trace left by the scotch tape on the orifice (shaded area in following figure) and the laser spot (the spots in following figure):

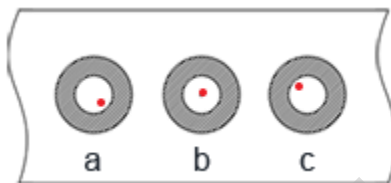

- b: the correct result of the dimming. The laser spot is in the center of the orifice
 - a and c: none of the laser spots is in the center of the orifice. Proceed to next step.
5. **Optional:** Adjust the following A and B adjusting screws in the adjustment mechanism of laser spot centering:

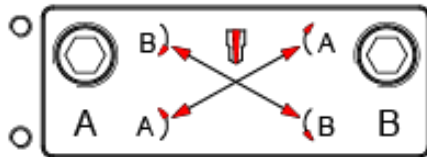

- To make the laser spot move towards the upper-right corner, adjust A.
- To make the laser spot move towards the upper-left corner, adjust B.
- To adjust both screws at the same time, first adjust the screw that needs to be unscrewed and then adjust the screw that needs to be screwed.

3.3. Check the Cutting Head for Verticality

This operation is used to check whether the cutting head is mounted vertically by judging whether Z-axis verticality is within the allowable range, and adjust the cutting head if not.

To check the cutting head for verticality, do the following:

1. Mount the cutting head on Z-axis mounting plate of the machine tool.
2. Move the cutting head to the follow-up height and mark on the sheet.
3. Move the cutting head to Z-axis upper limit, and mark the sheet.
4. Compare these two marks in above steps:
 - If the two marks overlap, it shows Z-axis verticality is within the allowable range.
 - If the two marks do not overlap, it shows the cutting head is not mounted vertically. Taking **SL-015C** as an example:

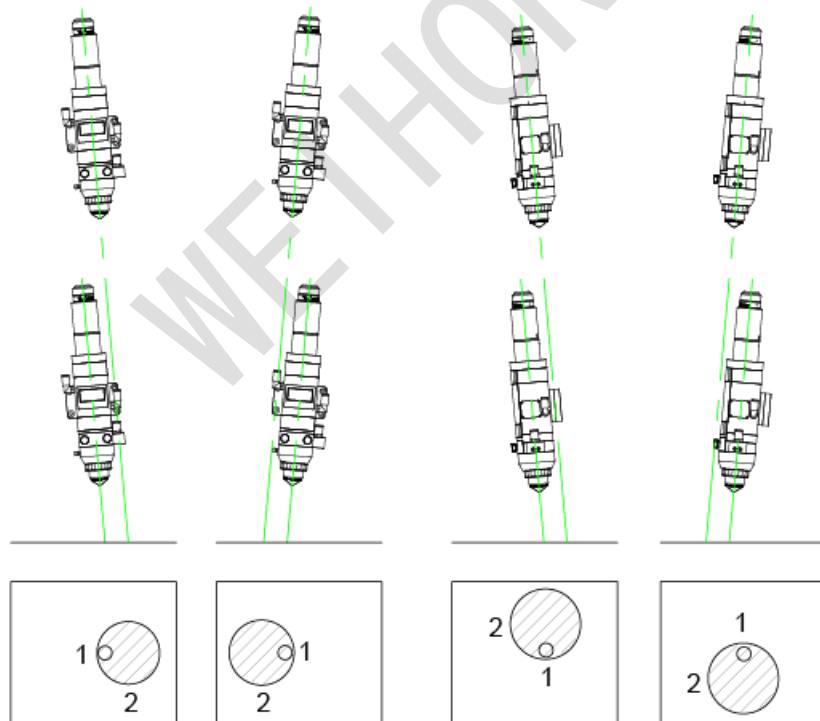

Proceed to next step.

5. **Optional:** According to the marking order and relation between the positions of the two marks, judge the inclined direction when mounting the cutting head, re-adjust its mounting angle, and repeat the above steps until the two marks overlap.

3.4. Test the Follow-up System

This operation is used to check whether the follow-up system works normally.

It is suggested to use our integrated follow-up system. And the cutting head can also match with other follow-up systems.

To ensure that the height sensing unit has been firmly mounted on the cutting head, and the cutting head has been firmly fixed on the extended board of the machine tool, before testing the follow-up system, do continuity test with multimeter, and check the following:

1. Conduction between the nozzle and the inner hole of RF cable interface:
 - If it succeeds, proceed to next step.
 - If it fails, consult our technical sales engineers.
2. Conduction between the nozzle and the shell of RF cable interface:
 - If it succeeds, consult our technical sales engineers.
 - If it fails, proceed to next step.
3. Conduction between the shell of RF cable interface and any uninsulated surface of the machine tool:
 - If it succeeds, proceed to next step.
 - If it fails, consult our technical sales engineers.
4. Conduction between the shell of the height sensing unit and any uninsulated surface of the machine tool:
 - If it succeeds, start testing the follow-up system.
 - If it fails, consult our technical sales engineers.

To test the follow-up system, do the following:

1. Power on and turn on the laser cutting CNC system.
2. Enable **Follow-up Mark** function to judge whether capacitance relation between the cutting head and the machined sheet is normal.

If the cutting head is 10cm away from the machined sheet, the value of real-time capacitance is about 1200,000.

If it is not normal, test the laser cutting CNC system.

3. Cut a piece of deformed sheet with the cutting head, and monitor the fluctuation of item **Real-time Error**.

If its fluctuation range does not exceed the allowable range, the follow-up system works normally.

If you adopt our follow-up system, please see [Follow-up System](#) for details.

3.5. Adjust the Zero Focal Position

This operation is used to precisely adjust the actual zero focal position to the range within 0.1mm, so as to solve the problem that it differs due to the difference of laser device's beam divergence angles.

Before adjusting the zero focal position, do the following:

1. Prepare the following material:
 - A single nozzle (Suggested: single 2.0 nozzle)
 - A piece of stainless steel sheet with thickness 0.5~1mm
 - Cutting gas: Nitrogen
2. Press **ON / OFF** on the cutting head, rotate the focusing rotary knob, and observe the following:
 - Whether the values of focus positions change normally:
If not, contact with our sale engineers.
 - Whether digital jump occurs or the rotation of the knob is smooth.
If digital jump occurs, check the machine tool for ground connection.
3. Set the theoretical zero focal position for optical element:
 1. To define the position of hard limit, rotate the focusing rotary knob until it cannot be rotated.

To define the upper hard limit, rotate to the left; to define to the lower hard limit, rotate to the right.
 2. Rotate 7mm.

To define the upper hard limit, rotate 7mm down; to define to the lower hard limit, rotate 7mm up.
 3. Press **ORIGIN** to reset.

To adjust the zero focal position, do the following:

1. Take 0.1mm as a gradient, and cut a piece of stainless steel sheet with thickness 0.5mm~1mm at the theoretical zero focal position above and below 1mm.
2. Measure the width of the kerf with a plug gauge:

The focal position corresponding to the thinnest kerf is the actual zero position.
3. Press **ORIGIN** to reset.

Example

Assuming that the focal position corresponding to the thinnest kerf is **-0.1**:

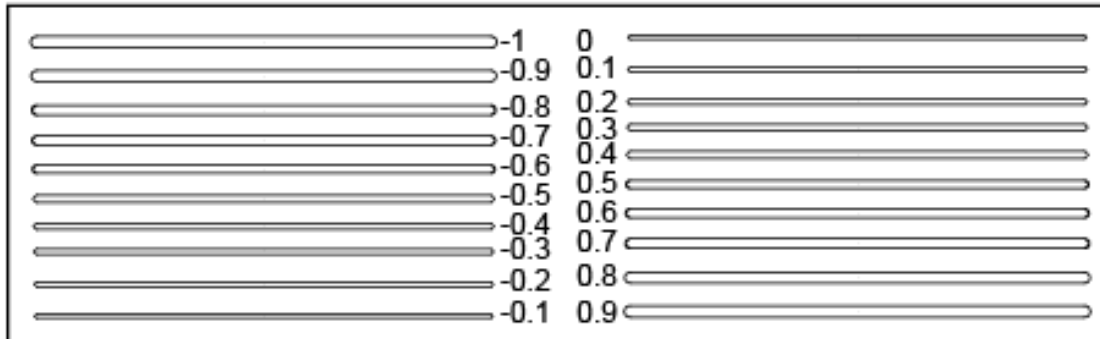

Then, the actual zero focal position is **-0.1**.

At this time, press **ORIGIN** to reset.

4. Maintenance

To maximize the life of **SL-015C**, you need to know knowledge about precautions and maintenance of wearing parts.

4.1. Precautions

The part includes precautions before running, in running and after running:

1. Before running, do the following:
 - Check whether the cutting head is fixed on the machine tool.
 - Check whether the fiber connector is correctly mounted on the cutting head.
 - Check whether the height sensing unit is fixed on the cutting head.
 - With multimeter, check whether abnormal conduction exists between the nozzle and the body of cutting head and whether the shell of height sensing unit is well connected to the ground wire.
 - Turn on water, and check whether the pipe is installed correctly and whether there is seepage among the parts.
 - Turn on the gas, and check whether the pipe is installed correctly and whether there is seepage on the installed positions of the nozzle.
 - Check whether the battery power is sufficient and the focal position displays normally.
 - Check whether the panel and the body of the cutting head fits well.
 - Check whether the laser spot is in the center of the nozzle.

2. In running, do the following:
 - Check the positions of collimator lens and focal lens of the cutting head for any abnormal temperature rise.
 - Check the joints of parts for seepage.
 - Check the fiber connector for any abnormal temperature rise and seepage.
 - When adjusting the focus, check adjustment knob for dust or debris.
 - After changing the nozzle or mounting the fiber connector again, check the laser spot again to see whether it is in the center of the nozzle.
 - Check whether there are spatters on the nozzle during seaming cutting.
3. After running, do the following:
 - Check the cutting head for seepage and condensed vapor.
 - Take out the protective lens, check the lens for water vapor, stains, burns and etc. If these exist, change the protective lens.
 - Check the nozzle for serious scratches and the orifice for abnormal deformation.
 - Check the joints of the connection parts for looseness.

4.2. Replacement and Maintenance of Wearing Parts

You need to make sure that the machine tool stops running during parts replacement or maintenance.

In order to secure the best performance of **SL-015C**, you need to replace the following parts timely according to the actual operating conditions:

- Focal protective lens
- Collimator protective lens
- Nozzle
- Spring seal for protective lens
- Battery

For proper and safe operation, regular maintenance and inspection on the cutting head according to the following requirements are essential:

- During the fiber connector replacement, use QBH plug to seal the QBH connector.
- When the cutting head is not in use, seal the inlet of gas and liquid adapters with rubber sleeve.
- During the fiber connector replacement, keep the cutting head horizontal as much as possible to prevent the dust from falling into the cutting head.
- When taking out the mounting base of the protective lens for a long time, seal the notch of the mount with seamless tape.

- When removing parts, clean the dust and debris around the parts first. If necessary, remove the whole cutting head and place it in a dust-free environment for dismantlement and maintenance.

5. Frequently Asked Questions (FAQs)

The following are the general questions that might occur during use, their corresponding causes and solutions. For any other questions, please contact with our sale engineers.

5.1. Kerf Exists Adhering Slag or It Is Not Cut Thoroughly.

Cause

1. The protective lens has been damaged.
2. The focus is not set correctly.
3. The pressure is not set properly.
4. The cutting speed is too fast.
5. The nozzle is not installed correctly.
6. Flow path leakage.
7. Incorrect setting of chiller temperature leads to moisture condensation of the lens.

Solution

1. Change the protective lens.
2. Based on the thickness of material and sheet, reset focal position.
3. Based on the thickness of material and sheet, reset the pressure.
4. Based on the forms of the adhering slag, judge and reset the cutting speed.
5. Reinstall the nozzle of the cutting head.
6. Check the leakage position with pure water or foam water.
7. Check chiller temperature, and set it properly.

5.2. One Side of the Kerf Exists Adhering Slag.

Cause

1. The laser spot is not in the center of the orifice.
2. Deformation occurs in the orifice.
3. The cutting head is not mounted vertically.

Solution

1. Re-adjust the position of laser spot.
 - For **SL-015C**, see [Check the Laser Spot for Centering](#) for details.
 - For **SL-030A**, see [Check the Laser Spot for Centering](#) for details.

2. Replace the nozzle.

3. Re-adjust the installation position of the cutting head.

See [Check the Cutting Head for Verticality](#) for details.

5.3. Kerf is Too Large.

Cause

1. The cutting head is not mounted vertically.
2. Proportion of focal length is too small.

Solution

1. Re-adjust the cutting head according to the inclination direction.

See [Check the Cutting Head for Verticality](#) for details.

2. Select another cutting head with greater proportion of focal length.

5.4. Temperature of the Cutting Head Rises.

Cause

1. The set temperature for cooling pump is too high.
2. The collimator lens or focal lens has been damaged.
3. Cooling flow path of the cutting head is blocked.

Solution

1. Lower the set temperature for cooling pump.
2. Contact our technical sales engineers to change the damaged lens.
3. Contact our technical sales engineers to check flow path.

5.5. The Center of the Orifice Cannot Detect Laser Emitting.

Cause

1. The laser spot is not within the orifice.
2. The shutter is off.
3. The laser device does not work normally.
4. Transparency of the scotch tape is too high.
5. Power for bursting is too low.

Solution

1. Remove the nozzle, coarsely adjust the laser spot to the center in the mount of the nozzle, install the nozzle, and finely adjust the position of the laser spot.
2. Check the shutter settings on the software.
3. Check the laser device to see whether it is on and whether it works properly.
4. Touch the scotch tape with fingers, and enable **Burst** function.
5. Raise power for bursting on the software, and enable **Burst** function.

5.6. There is No Trace on the Surface of the Sheet in Marking.

Cause

1. Follow-up height is too high or power for marking is too low.
2. The shutter is off.
3. The laser device does not work normally.

Solution

1. Check settings for follow-up height and power for marking on the software to see whether they are within allowable ranges.
2. Check the shutter settings on the software.
3. Check laser device to see whether it is on and whether it works properly.

SPECIALIZED / CONCENTRATED / FOCUSED



Shanghai Weihong Electronic Technology Co., Ltd.

Address: No. 1590, Huhang Rd., Fengxian, Shanghai, China, 201401

Hot-line: 400 882 9188

Website: www.weihong.com.cn/en