

# Lambda Series CNC System

## Manufacturers' Manual

---

9th Edition

(For PM85A/95A, NC65A/65B/65C)

Weihong Electronic Technology Co., Ltd.

The copyright of this manual belongs to Weihong Electronic Technology Co., Ltd. (hereinafter referred to as Weihong Company). This manual and any image, table, data or other information contained in this manual may not be reproduced, transferred, or translated without any prior written permission of Weihong Company.

The information contained in this manual is constantly being updated. You can login to the official website of Weihong Company [www.weihong.com.cn/en/](http://www.weihong.com.cn/en/) to download the latest PDF edition for free.

# Preface

## About This manual

This manual is intended for manufacturers. If you use the CNC system for the first time, you need to read through the manual. If you are experienced with the system, you can search for the desired info via the contents.

With 7 chapters, this manual can be divided into 4 parts, as follows:

- 1) Part 1: preface, introducing the precautions about transportation and storage, installation, wiring, debugging, usage, and so on. You need to read them carefully beforehand to ensure safe operations.
- 2) Part 2: product, including chapter 1~4. Chapter 1 is product overview, chapter 2 wiring, chapter 3 and 4 are installation and machine debugging.
- 3) Part 3: appendix, including chapter 5~6. Chapter 5 lists parameter settings and wiring diagrams of various drivers. Chapter 6 introduces certain important terms and concepts in motion control field.
- 4) Part 4: software license agreement in chapter 7.

## Applicable Product Models

This manual is applicable to Lambda series CNC system, including NC65A/65B/65C host, PM85A/95A communication card and Lambda series controller. Refer to the table below for details:

Product Model	Remarks
NC65A/65B host	Integrating CPU, 60G SSD, 1G RAM, communication card and NcStudio motion control software, used together with Lambda 4S/5S controller.
NC65C host	Integrating dual-core CPU, 60G SSD, 2G RAM, communication card and motion control software NcStudio, NC65C is an upgraded product in terms of mainboard on the basis of NC65B, and can be used together with Lambda 3S/3L/4S/5S/5E/5M controllers.
PM85A/95A communication card	Self-developed multi-axis communication card, used together with Lambda series controllers.
Lambda series controller	High-performance integrated controllers, including Lambda 3S/3L/4S/5S/5E/5M, used together with PM85A/95A communication cards or NC65A/65B/65C hosts. Lambda 5M is applied in bus CNC systems or systems with absolute encoders, while Lambda 3S/3L/4S/5S/5E is applied in non-bus CNC systems.

## Revision History

You can refer to the following table for the revision records of each edition.

Date	Edition	Revision
2017.02	R9	1) Add section 1.7 <i>Lambda 5M Controller</i> ; 2) Add section 2.3 <i>Lambda 5M Controller</i> ; 3) Add section 5.2.2 <i>Parameter Setting of WISE Servo Driver(Bus)</i> ; 4) Add section 5.2.5 <i>Parameter Setting of YASKAWA <math>\Sigma</math>-7 Servo Driver(Bus)</i> ; 5) Update section 1.9.2, 1.10, 2.1, 2.2.4, 2.4.2, 4.1 and 6.3; 6) Other revisions.
2016.10	R7.3	1) Wiring diagram of laser cutting software in section 2.2.4 updated. 2) Settings for parameters “Screw pitch”, “PG division ratio (X4)” and “Allowable move distance at power off” in section 6.2.5 updated. 3) Settings for parameters Pr008, Pr009, Pr010 and Pr0.08, Pr0.09 and Pr0.10 in section 5.1.1, 5.2.1 and 5.2.7 updated. 4) Remarks added in section 5.1.6 and 5.2.9. 5) Terminals in wiring diagram with DELTA servo driver in section 5.4.6 revised.
2016.02	R7	1) Contact information updated; 2) Wiring diagrams related to Lambda controllers updated in section 1.4, 1.5, 1.6, 2.1 and 2.2; 3) Add wiring diagrams of Lambda controllers in two-axis and three-axis configuration of waterjet cutting software in section 2.2.3; 4) Wiring diagrams in section 5.4 updated.
2015.12	R6	1) Update chapter 2.2.1, including revision of wiring in case of standard configuration of three-axis engraving and milling software, and additions of wirings in case of disk-type tool magazine and linear tool magazine of three-axis engraving and milling software. 2) Revision of parameter setting in chapter 6.2.5. 3) Other revisions.
2015.11	R5	1) Add chapter 1.6 introduction to Lambda 5E controller. 2) Add chapter 2.2.3 wiring diagram of Lambda 5E controller in case of AC-type machine in waterjet cutting application as well as descriptions of the driver interfaces when Lambda 5E controller is used together. 3) Add chapter 6.2 introduction to absolute encoder function. 4) Update of chapter 5 wiring diagrams of the controller and the driver. 5) Add chapter 1.2 introductions to NC65C host and other information related to NC65C in other chapters. 6) Other revisions.
2015.07	R3	1) Update of 2.1 <i>Lambda 3S/3L Controller</i> according to the latest software; 2) Update of 2.2 <i>Lambda 4S/5S/5E/5M Controller</i> according to the latest software; 3) Update of 3.1.2 <i>Driver Update</i> ; 4) Update of 3.2.1 <i>Software Setup</i> ; 5) Other revisions.



## Contact Us

You can contact us by the following info for technical support and pre-sales/after-sales service:

Company Name: Weihong Electronic Technology Co., Ltd.  
Headquarters Address: No.1590, Huhang Rd., Fengxian, Shanghai, PRC 201400  
Tel: +86-21-33587550  
Fax: +86-21-33587519  
Website: <http://www.weihong.com.cn/en/>

## Precautions

Precautions can be divided into caution and warning according to the degree of possible loss or injury in case of negligence or omission of precautions stipulated in this manual.



: general info, mainly for informing, such as supplementary instructions and conditions to enable a function. In case of negligence or omission of this kind of precautions, you may not activate a function. Note that in some circumstances, negligence or omission of even this kind of precautions could cause physical injury or machine damage.



: warning info requiring special attention. In case of negligence or omission of this kind of precautions, you may suffer physical injury, or even death, machine damage or other losses.



### 1) Precautions Related to Storage and Transportation

- The products should be transported properly in terms of the weight;
- An excess of specified quantity of stacking products is prohibited;
- Climbing, standing or placing heavy loads on the products is prohibited;
- Dragging or carrying the products via cables or devices connected to them is prohibited;

### 2) Precautions Related to Installation

- Only when this equipment installed in the qualified electricity cabinet can it be used. The construction of the cabinet must reach IP54 grade of protection;
- Paste sealing strips on the joint of the cabinet to seal all the cracks;
- Cable entry should be sealed while easy-to-open on the spot;
- A fan or heat exchanger should be adopted for the heat dissipation and air convection of the cabinet;
- If a fan is adopted, air strainer is a must in air inlet or air outlet;
- Dust or cutting fluids may have access to the CNC device via the tiny cracks and tuyere. Therefore it is necessary to pay attention to the surroundings and air flow direction of the air vent to make sure that the outflow gas is towards pollution source;
- 100 mm space should be preserved between the back of the CNC device and the cabinet wall for plugging cable connected with the device and the ventilation & heat dissipation in the cabinet;
- Space between this device and other equipment should also be preserved according to the requirements;
- The product should be installed firmly and without vibration. During installing, casting, knocking, striking, or loading on the product is forbidden;
- To reduce electromagnetic interference, power-supply components used should be above AC or DC 50V and the space between cable and CNC device should be preserved above 100mm;



- It will be better if CNC device is installed at a position facilitating debugging and maintenance.

### **3) Precautions Related to Wiring**

- Only qualified people are allowed to participate in the wiring and checking;
- The CNC device should be grounded reliably and grounding resistance should be less than 4 ohm. Neutral line is absolutely not allowed to replace earth wire. Otherwise, it may result in malfunction of the device due to the interference;
- Wiring should be firm and steady, or misoperation may occur;
- Voltage values and positive & negative polarity of any connection plug should be in accordance with specifications set forth in the manual, or it may result in breakdowns such as short circuit and permanent damage to the device;
- To guard against electric shock or CNC device damage, fingers should keep dry before plugging or touching switch;
- The connecting wire should not be damaged and squeezed, or the leakage or short circuit may occur;
- It is prohibited to plug or open the chassis of CNC device when power on.

### **4) Precautions Related to Running & Debugging**

- Parameters setting should be checked before running, since wrong setting may lead to accidental movements;
- Modification to parameters should be within the allowable range, or such breakdowns as unsteady running and machine damage will occur.

### **5) Precautions in Use**

- Before power-on, please make sure that the switch is on blackout to avoid occasional start-up;
- Please check the electromagnetic compatibility during electrical design in order to avoid or reduce electromagnetic interference to the CNC device. A low pass filter should be employed to reduce electromagnetic interference if there are other electrical devices nearby;
- It is not allowed to frequently power on and power off. It is recommended to power up the machine again at least one (1) minute later after power failure or blackout.

**1) Precautions Related to Product and Manual**

- Matters related to restrictions and functions available stipulated in the manuals issued by the machine manufacturer are prior to those in this manual;
- This manual assumes all the optional functions are available, which you must confirm through manuals issued by the machine manufacturer;
- Please refer to manuals issued by the machine manufacturer for the instructions of machine tools;
- Functions, and software interfaces vary with the system and the version of software. Before using the system, you must confirm the specifications.

**2) Precautions When Opening the Package**

- Please make sure that the products are what you have ordered;
- Check if the products are damaged in transit;
- Check if the components and accessories are damaged or missing in terms of the detailed list;
- Please contact us promptly if product discrepancy, accessory missing or transit damage occurs.

# Contents

<b>1</b>	<b>Overview</b> .....	<b>1</b>
1.1	Host NC65A/65B.....	1
1.2	Host NC65C.....	2
1.3	Communication Card PM85A/95A.....	2
1.3.1	Structural Drawing of Communication Card PM85A.....	3
1.3.2	Structural Drawing of Communication Card PM95A.....	3
1.4	Lambda 3S/3L Controller.....	4
1.5	Lambda 4S/5S Controller.....	5
1.6	Lambda 5E Controller.....	6
1.7	Lambda 5M Controller.....	7
1.8	System Running Status Description.....	8
1.9	Configuration.....	8
1.9.1	Lambda 3S/3L CNC System.....	8
1.9.2	Lambda 4S/5S/5E/5M Series CNC System.....	9
1.10	Overall Connection Diagram.....	10
<b>2</b>	<b>Wiring</b> .....	<b>12</b>
2.1	Lambda 3S/3L Controller.....	12
2.1.1	Wiring of Lambda 3S Controller.....	12
2.1.2	Definitions of Inputs.....	13
2.1.3	Definitions of Outputs.....	14
2.2	Lambda 4S/5S/5E/5M Controller.....	15
2.2.1	Wiring in Engraving and Milling software.....	15
2.2.1.1	Three-axis Configurations in Engraving and Milling Software.....	16
2.2.1.2	Four-axis Configuration in Engraving and Milling Software.....	19
2.2.1.3	Five-axis AC Configuration in Engraving and Milling Software.....	20
2.2.2	Wiring in Glass Cutting Software.....	21
2.2.2.1	XYA Configuration in Glass Cutting Software.....	21
2.2.2.2	XYZA Configuration in Glass Cutting Software.....	23

2.2.2.3	X1YAX2 Config in Glass Cutting Software .....	25
2.2.2.4	XYA No Edge Configuration in Glass Cutting Software .....	27
2.2.2.5	XYZA No Edge Config in Glass Cutting Software.....	28
2.2.3	Wiring in Waterjet Cutting Software .....	29
2.2.3.1	XY1Y2 Configuration in Waterjet Cutting Software.....	30
2.2.3.2	XY1Z2 Configuration in Waterjet Cutting Software .....	32
2.2.3.3	XYC Configuration in Waterjet Cutting Software.....	34
2.2.3.4	XY1CY2 Configuration in Waterjet Cutting Software .....	36
2.2.3.5	XYZC Configuration in Waterjet Cutting Software.....	38
2.2.3.6	XY1ZCY2 Configuration in Waterjet Cutting Software.....	40
2.2.3.7	StadA with 2Y Configuration in Waterjet Cutting Software .....	42
2.2.3.8	In case of Five-axis Waterjet Cutting Machines of AC-type .....	45
2.2.4	Wiring of Three-axis Configuration in Laser Cutting Software .....	47
2.2.5	Wiring in Dual Z Axes Configuration Software.....	50
2.2.6	Wiring in Three Z Axes Configuration Software.....	52
<b>2.3</b>	<b>Lambda 5M Controller .....</b>	<b>53</b>
2.3.1	Waterjet Cutting .....	54
2.3.2	NK280B .....	56
2.3.3	NK300CX.....	58
2.3.3.1	Integrated software .....	58
2.3.3.2	Union configuration in multi Z software .....	60
2.3.3.3	Turn configuration in multi Z software.....	62
2.3.3.4	Dual Y union configuration in multi Z software .....	64
2.3.4	NK500 .....	65
2.3.5	NcStudio V10 Three-axis Dual Z axes .....	66
2.3.6	NcStudio V10 Three-axis Quadruple Z.....	68
<b>2.4</b>	<b>Driver Interface.....</b>	<b>70</b>
2.4.1	Lambda 3S/3L Controller.....	70
2.4.2	Lambda 4S/5S/5M Controller .....	70
2.4.3	Lambda 5E Controller .....	71
<b>2.5</b>	<b>MPG Interface.....</b>	<b>73</b>
<b>2.6</b>	<b>Extended Terminal Board Interface .....</b>	<b>74</b>
2.6.1	Cascade Connection .....	74
2.6.2	Non-cascade Connection .....	74
<b>2.7</b>	<b>Signal Types .....</b>	<b>75</b>
2.7.1	Binary Input Signal.....	75
2.7.2	Relay Output Signal .....	75

2.7.3	Servo Enable Signal.....	75
2.7.4	Encoder Signal .....	76
2.7.5	Command Pulse Signal .....	76
2.7.6	Analog Output Signal.....	77
<b>3</b>	<b>Installation .....</b>	<b>78</b>
<b>3.1</b>	<b>PM85A/95A Communication Card .....</b>	<b>78</b>
3.1.1	Installation Steps .....	78
3.1.2	Driver Update .....	78
3.1.3	Customization of Setup Installation Package.....	82
<b>3.2</b>	<b>NC65A/65B/65C Host .....</b>	<b>83</b>
3.2.1	Software Setup .....	83
3.2.2	OS Backup and Restore.....	85
3.2.2.1	First-time OS Backup.....	85
3.2.2.2	Other Backups.....	85
3.2.2.3	OS Restore.....	86
3.2.3	OS Backup and Restore via USB Flash Disk .....	87
3.2.3.1	Preparation .....	87
3.2.3.2	Setup.....	87
3.2.3.3	OS Backup and Restore .....	88
<b>4</b>	<b>Machine Tool Debugging.....</b>	<b>90</b>
<b>4.1</b>	<b>Debugging Steps .....</b>	<b>90</b>
<b>4.2</b>	<b>Pulse Test .....</b>	<b>94</b>
4.2.1	Stepping Driver .....	94
4.2.2	Servo Driver .....	94
<b>5</b>	<b>Driver Parameter Settings and Wiring Diagrams .....</b>	<b>95</b>
<b>5.1</b>	<b>Driver Parameter Setting (Lambda 3S/3L).....</b>	<b>95</b>
5.1.1	Parameter Setting of WISE Servo Driver .....	95
5.1.2	Parameter Setting of YASKAWA $\Sigma$ -II Servo Driver.....	97
5.1.3	Parameter Setting of DELTA ASDA-A Servo Driver .....	98
5.1.4	Parameter Setting of DELTA ASDA-B Servo Driver .....	99
5.1.5	Parameter Setting of Panasonic MINAS A4 Servo Driver .....	100
5.1.6	Parameter Setting of MITSUBISHI MR-E Servo Driver .....	101

5.1.7	Parameter Setting of FUJI FALDIC-β Servo Driver .....	102
5.1.8	Parameter Setting of STONE GS Servo Driver .....	103
<b>5.2</b>	<b>Driver Parameter Setting (Lambda 4S/5S/5E/5M) .....</b>	<b>104</b>
5.2.1	Parameter Setting of WISE Servo Driver(Pulse).....	104
5.2.2	Parameter Setting of WISE Servo Driver(Bus).....	106
5.2.3	Parameter Setting of YASKAWA Σ- II Servo Driver.....	107
5.2.4	Parameter Setting of YASKAWA Σ- V / Σ-7 Servo Driver.....	109
5.2.5	Parameter Setting of YASKAWA Σ-7 Servo Driver(Bus).....	111
5.2.6	Parameter Setting of Panasonic MINAS A4 Servo Driver .....	117
5.2.7	Parameter Setting of Panasonic MINAS A5 Servo Driver .....	119
5.2.8	Parameter Setting of MITSUBISHI MR-JE Servo Driver .....	121
5.2.9	Parameter Setting of MITSUBISHI MR-E Servo Driver .....	122
5.2.10	Parameter Setting of DELTA ASDA-A Servo Driver .....	123
5.2.11	Parameter Setting of DELTA ASDA-A2 Servo Driver .....	126
5.2.12	Parameter Setting of DELTA ASDA-B Servo Driver .....	128
5.2.13	Parameter Setting of DELTA ASDA-B2 Servo Driver .....	130
5.2.14	Parameter Setting of SANYO PY Servo Driver.....	132
5.2.15	Parameter Setting of SANYO R Servo Driver.....	134
5.2.16	Parameter Setting of SANYO Q Servo Driver .....	135
5.2.17	Parameter Setting of KT270 Servo Driver .....	136
5.2.18	Parameter Setting of FUJI FALDIC-β Servo Driver .....	138
5.2.19	Parameter Setting of Stone GS Servo Driver .....	139
5.2.20	Parameter Setting of TECO TSDA Servo Driver .....	141
<b>5.3</b>	<b>Wiring Diagrams with Drivers (Lambda 3S/3L) .....</b>	<b>142</b>
5.3.1	Wiring with Stepping Driver with Common Port.....	142
5.3.2	Wiring With Differential Input Stepping Driver.....	142
5.3.3	Wiring with WISE Servo Driver .....	143
5.3.4	Wiring with YASKAWA Σ- II Servo Driver .....	144
5.3.5	Wiring with DELTA ASDA-A/AB Servo Driver.....	145
5.3.6	Wiring with PANASONIC MINAS A4 Servo Driver .....	146
5.3.7	Wiring with MITSUBISHI MR-E Servo Driver.....	147
5.3.8	Wiring with FUJI FALDIC-β Servo Driver .....	148
5.3.9	Wiring with STONE GS Servo Driver .....	148
<b>5.4</b>	<b>Wiring Diagrams with Drivers (Lambda 4S/5S/5M).....</b>	<b>148</b>



5.4.1	Wiring Diagram with WISE Servo Driver .....	149
5.4.2	Wiring Diagram with YASKAWA AC Servo Driver .....	150
5.4.3	Wiring Diagram with PANASONIC AC Servo Driver .....	151
5.4.4	Wiring Diagram with MITSUBISHI MR-JE Servo Driver .....	152
5.4.5	Wiring Diagram with MITSUBISHI MR-E Servo Driver .....	153
5.4.6	Wiring Diagram with DELTA Servo Driver .....	153
5.4.7	Wiring Diagram with FUJI Servo Driver .....	156
5.4.8	Wiring Diagram with HITACHI Servo Driver .....	156
5.4.9	Wiring Diagram with SANYO PY Servo Driver .....	157
5.4.10	Wiring Diagram with SANYO R Servo Driver .....	158
5.4.11	Wiring Diagram with KT270 Servo Driver .....	158
5.4.12	Wiring Diagram with STONE GS Servo Driver .....	159
5.4.13	Wiring Diagram with TECO TSDA Servo Driver .....	160
5.4.14	Wiring Diagram with TECO ESDA Servo Driver .....	161
<b>6</b>	<b>Appendix .....</b>	<b>162</b>
<b>6.1</b>	<b>Back to Machine Zero (Back to Reference Point) .....</b>	<b>162</b>
6.1.1	Principle of Returning to Machine Origin (without Encoder Feedback) .....	163
6.1.2	Principle of Returning to Machine Origin (with Encoder Feedback) .....	165
<b>6.2</b>	<b>Absolute Encoder Function .....</b>	<b>166</b>
6.2.1	Brief Introduction to Absolute Encoder .....	166
6.2.2	Hardware Basis of Absolute Encoder .....	166
6.2.3	Driver Setup .....	168
6.2.4	How to Use Absolute Encoder Function in the Software .....	168
6.2.5	Parameter Setup in the Software .....	169
<b>6.3</b>	<b>Pulse Equivalent Adjustment .....</b>	<b>170</b>
6.3.1	Concept of Pulse Equivalent .....	170
6.3.2	Calculation of Pulse Equivalent .....	171
<b>6.4</b>	<b>Electronic Gear Ratio .....</b>	<b>172</b>
6.4.1	Electronic Gear .....	172
6.4.2	Electronic Gear Functions .....	172
6.4.3	Computing Method of Electric Gear Ratio .....	173
6.4.4	Samples of Electronic Gear Setting .....	174

**7 Software License Agreement.....177**

# 1 Overview

## 1.1 Host NC65A/65B

Independently developed and industrial-mainboard based, NC65A/65B integrated CNC system comprises Lambda 4S/5S controller and NC65A/65B host integrating CPU, 60G SSD, 1G RAM, control card and NcStudio motion control software, having proven its daily use in glass edging, glass cutting, engraving & milling, and other cutting industries.

Running on PC-based OS platform, NC65A/65B, through strict EMC test, is with digital verification function and thus anti-virus, featuring high reliability, high cost performance and compact design.

There are some external interfaces on host NC65A/65B:

- L, N and E: live wire, neutral wire and earth wire respectively, for external connection with 220V power supply;
- USB: for external connection with USB device (e.g. USB flash drive);
- LAN: Ethernet port, 100Mbps;
- VGA: video output interface;
- Terminal board: for external connection with Lambda 4S/5S controller;
- Fuse: replaceable, only available in NC65B host.

Dimensional drawings of NC65A/NC65B are shown as Fig. 1-1 and Fig. 1-2.

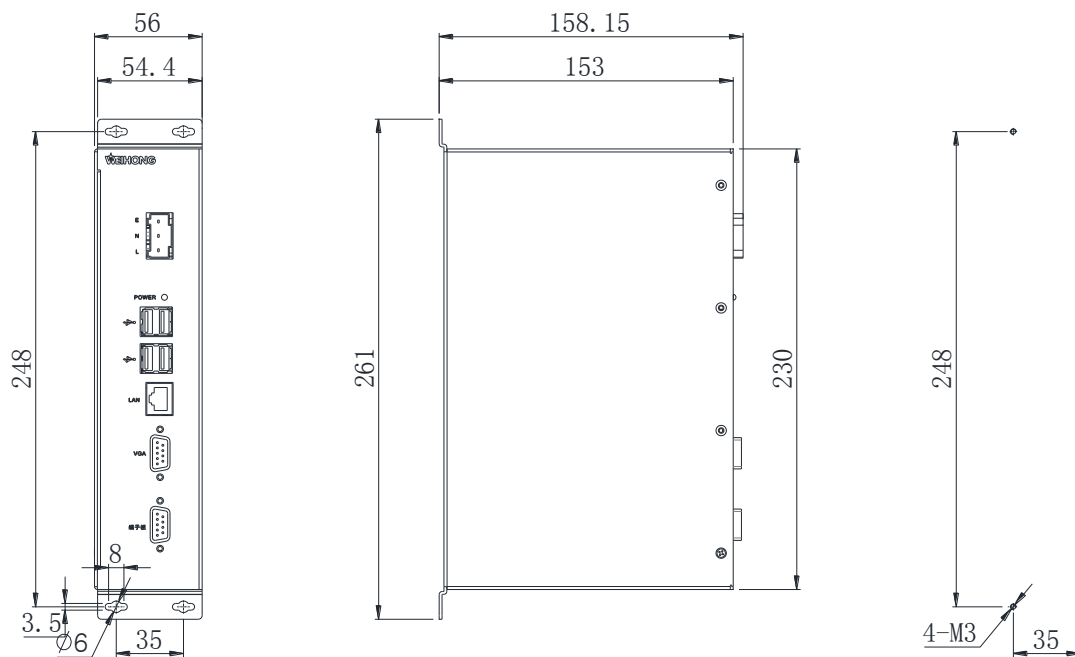

Fig. 1-1 Dimensional drawing of NC65A host

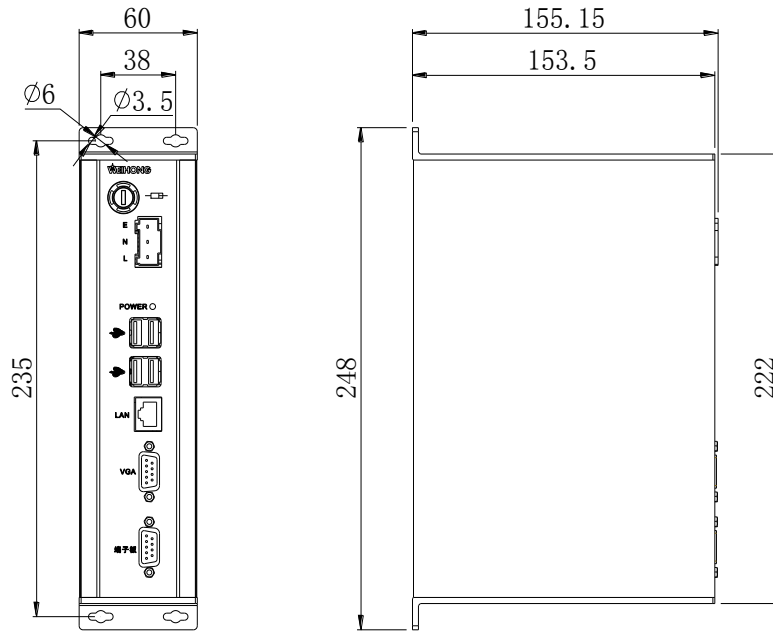

Fig. 1-2 Dimensional drawing of NC65B host

## 1.2 Host NC65C

Independently developed by Weihong Electronic Technology Co., Ltd, NC65C host is an upgraded product on the basis of NC65B in terms of mainboard. Upgraded mainboard boasts faster CPU clock speed and memory data rate, or 40% higher performance compared with NC65A/65B. Running on Win8.1-32bit operating system, NC65C features faster boot speed and better anti-virus function. Specifically, NC65C host takes dual-core CPU, 60G SSD, 2G RAM, communication card, NcStudio motion control software as a whole, and can be used together with Lambda 3S/3L/4S/5S/5E/5M controllers, depending number of axes and applied industries.

Dimension of NC65C host is 248mm\*153.5mm\*60mm, same as dimension of NC65B host. You can refer to Fig. 1-2 for details.

For definition of external interfaces on NC65C host, you can turn to the counterpart information of NC65A/65B in section 1.1. However, please note that, terminal board interfaces on NC65C host can be connected to Lambda 3S/3L/4S/5S/5E/5M controller. You can choose suitable Lambda controller according to number of axes, and requirement of encoder feedback function or bus function.

## 1.3 Communication Card PM85A/95A

Independently developed by Weihong Electronic Technology Co., Ltd., communication card PM85A/95A, when used with NcStudio motion control software, has proven itself in daily use on routers, engraving and milling machines, drilling machines and cutting machines, available of comprehensive functions and convenient to use.

### 1.3.1 Structural Drawing of Communication Card PM85A

PM85A should be inserted into a PCI slot, and its dimension is 138.4mm \* 59.7mm.

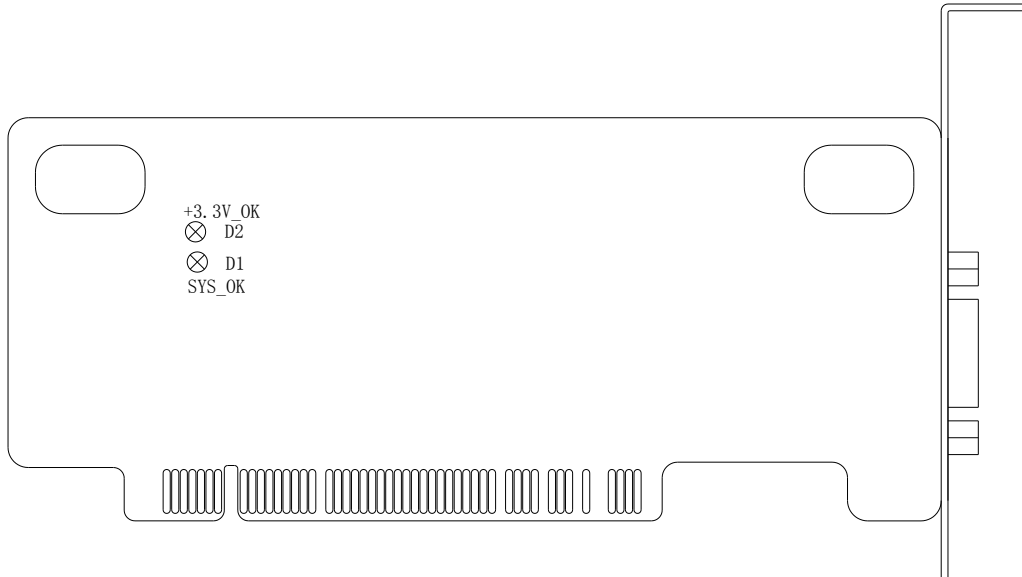

Fig. 1-3 Structural drawing of communication card PM85A

### 1.3.2 Structural Drawing of Communication Card PM95A

PM95A should be inserted into a PCI-E slot, and its dimension is 138mm \* 60.5mm.

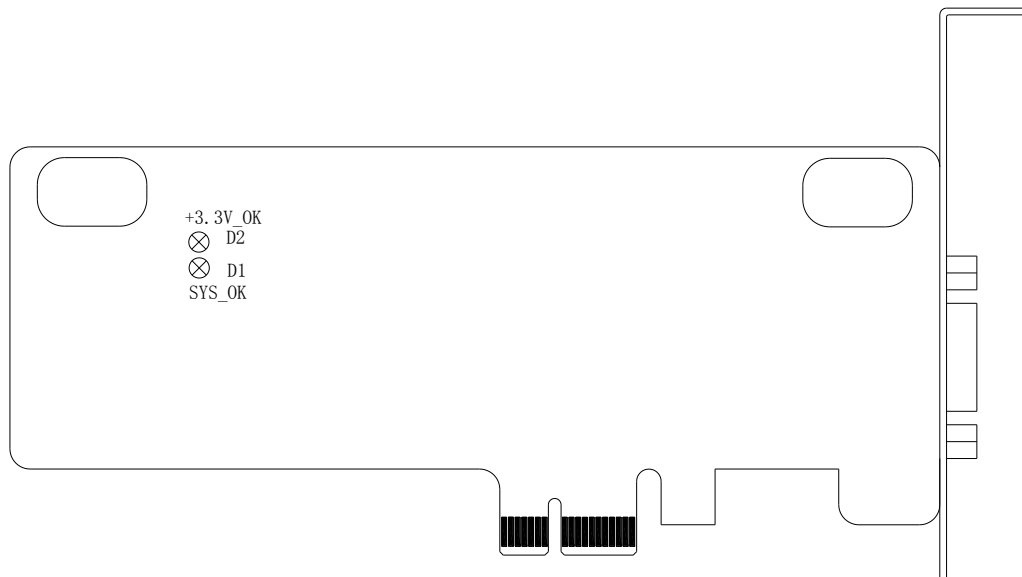

Fig. 1-4 Structural drawing of communication card PM95A



Both PM85A and PM95A have two indicator lamps: +3.3V\_OK (D2) and SYS\_OK (D1). The latter one is the system indicator lamp. See Section 1.6 for details. The former one is the power indicator lamp, on after the card is correctly inserted into the PC slot and the PC is started.

## 1.4 Lambda 3S/3L Controller

Independently developed by Weihong Electronic Technology Co., Ltd., Lambda 3S/3L controller, used together with PM85A/95A communication card, is mainly applied to controlling routers, engraving and milling machines, drilling machines and cutting machines, available of comprehensive functions and convenient to use. Generally, Lambda 3S/3L controller is used together with stepping motor drivers.

Lambda 3S supports time registration function for the driver while Lambda 3L does not. Besides, Lambda 3S has a MPG interface while Lambda 3L does not have a MPG interface. Their other functions are the same.

Lambda 3S/3L controller includes the following features:

- Enclosed controller, oil-proof, dust-proof, and water-proof;
- Serial communication, high speed 485 interface, baud rate 10Mbps;
- Max. pulse output frequency: 1MHz;
- Fewer cables and easier wiring;
- On-line update of firmware; hardware adaptable, software customizable;
- Hardware encryption and software encryption for safety concerns;
- Input polarity adjustable, inputs active high/ low.

See Fig. 1-5 for the dimensional drawing of Lambda 3S. The dimension of Lambda 3L is the same as that of Lambda 3S.

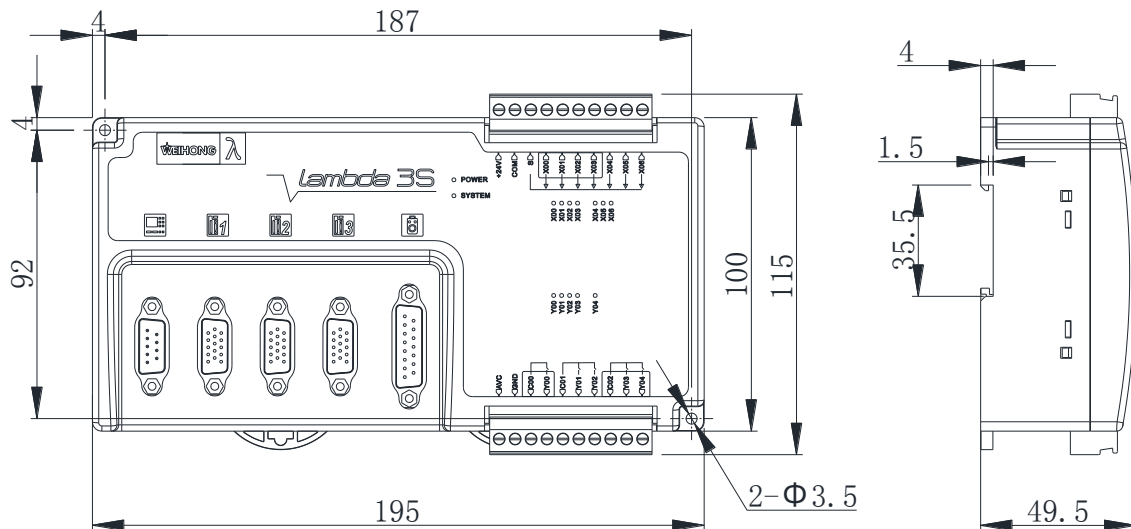

Fig. 1-5 Dimensional drawing of Lambda 3S

## 1.5 Lambda 4S/5S Controller

Fully enclosed, Lambda 4S/5S controller not only has better protection, but also improves appearance and quality. With a brand new hardware design scheme for the control board in the controller, Lambda 4S/5S is designed in an integrated way, extensively applied in engraving & milling, waterjet cutting, glass cutting and other industries.

Lambda 5S can support motion control of up to 5 axes, while Lambda 4S up to 4 axes.

Lambda 4S/5S controller includes the following features:

- Enclosed controller, oil-proof, dust-proof, and water-proof;
- Input polarity adjustable, inputs active high/ low;
- Serial communication, high speed 485 interface, baud rate 10Mbps;
- Max. pulse output frequency: 1MHz;
- Fewer cables and easier wiring;
- On-line update of firmware; hardware adaptable, software customizable;
- Hardware encryption and software encryption for safety concerns;
- Incremental encoder feedback function available;
- 2 to 5 axes motion control;
- Time registration function for drivers available.



As with interfaces of external terminal boards, cascade connection is **unavailable** in Lambda 4S, while **available** in Lambda 5S.

See Fig. 1-6 for the dimensional drawing of Lambda 5S controller, whose dimension is the same as that of Lambda 4S controller.

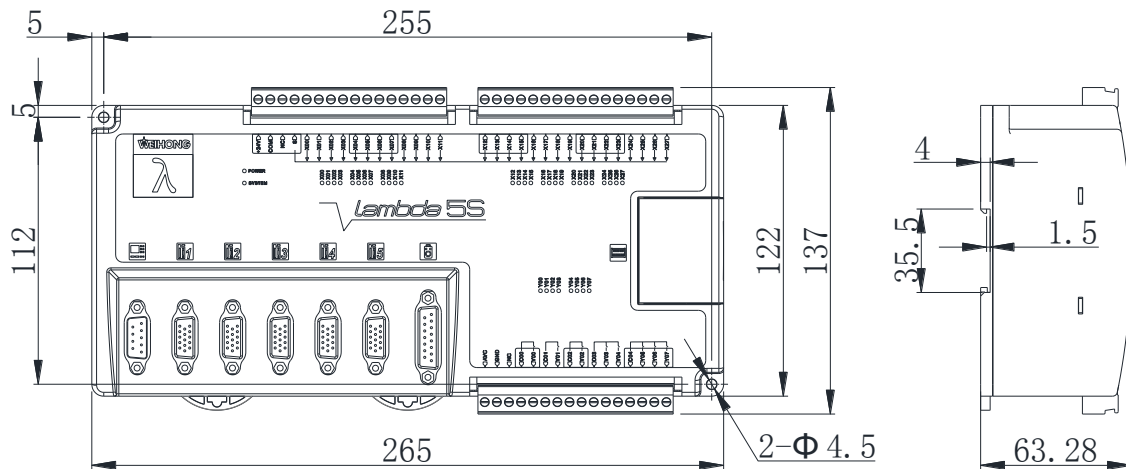

Fig. 1-6 Dimensional drawing of Lambda 5S controller

## 1.6 Lambda 5E Controller

Based on the Lambda 5S controller, Lambda 5E controller supports absolute encoder function, and can be widely used in such industries as milling and engraving, waterjet cutting, glass cutting.

Lambda 5E controller can support motion control of up to 5 axes.

Lambda 5E controller includes following features:

- Enclosed controller, oil-proof, dust-proof, and water-proof, enhanced stability;
- Input polarity adjustable, inputs active high/low supported;
- Serial communication, high speed 485 interface, baud rate 10Mbps;
- Max. pulse output frequency: 1MHz;
- Fewer cables and easier wiring;
- On-line update of firmware; hardware adaptable and software customizable;
- Hardware encryption and software encryption for safety concerns;
- Encoder feedback from both incremental and absolute encoders available;
- 2 to 5 axes motion control;
- Time registration function for drivers available.

See Fig. 1-7 for dimensional drawing of Lambda 5E controller:



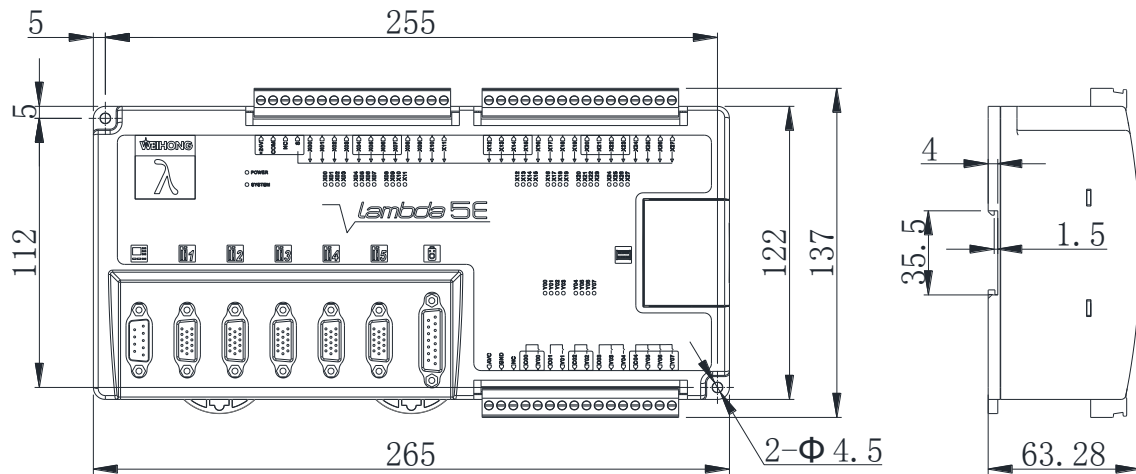

Fig. 1-7 Dimensional drawing of Lambda 5E controller

## 1.7 Lambda 5M Controller

Based on Lambda 5S controller, Lambda 5M controller supports bus function, and can be widely used in such industries as milling and engraving, wood and 3C.

Lambda 5M controller includes the following features:

- Enclosed controller, oil-proof, dust-proof, and water-proof, enhanced stability;
- Support 24V power;
- Support a group of spindle analog output with voltage range 0~10V, and precision 0.2V;
- 28 common input ports(X00~X27). Support modification of input polarity and active high/low inputs;
- 8 common output ports(X00~X07). Port Y00/Y01 is added with protective circuit and voltage under 24V for brake;
- 1 pulse axis interface, which supports control of pulse axis. Max. pulse output frequency: 1MHz;
- 1 Mechatrolink- II interface which supports bus control of at most 8 axes;
- 1 MPG interface, which supports control of at most 6 axes through MPG;
- 1 extended interface for cascade. Serial communication, high-speed 485 interface, baud rate 10Mbps;
- On-line update of firmware; hardware adaptable and software customizable;
- Phoenix communication. Communication cycle of link layer is 50μs.
- Support encoder latch and absolute encoder feedback;
- Support M2 communication mode. Pulse interpolation cycle is 1ms.
- Support slave station loss detection and station address set.
- Fewer cable and elbow plug terminal, which is easier to wire.
- Time registration function for drivers available.

See Fig. 1-8 for dimensional drawing of Lambda 5M controller:

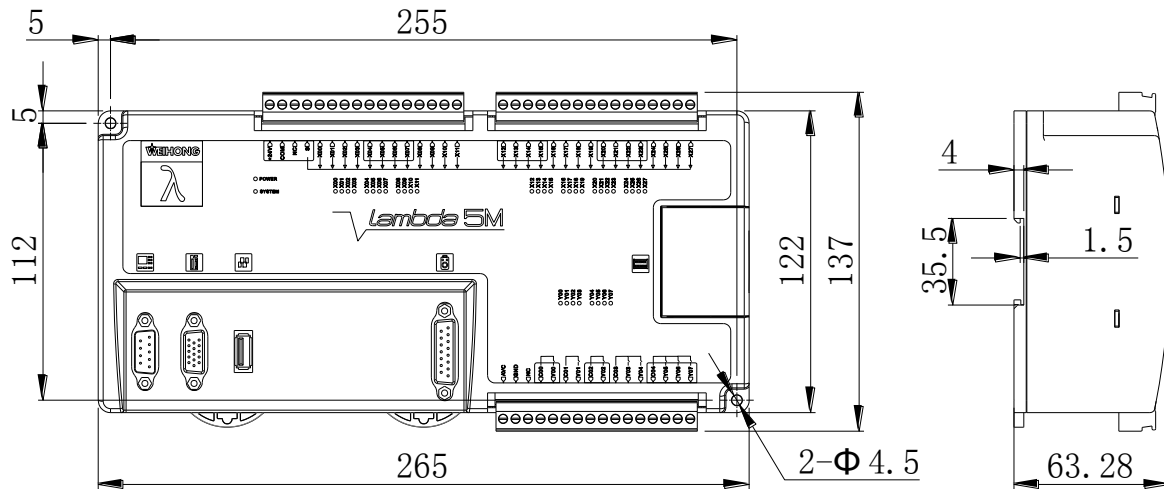

Fig. 1-8 Dimensional drawing of Lambda 5M controller

## 1.8 System Running Status Description

The system indicator lamp of PM85A/95A is SYS\_OK, while that of Lambda series controllers is SYSTEM. Their flash frequency is used to tell whether the system communication is normal, as follows:

- When the machine tool is in idle status, the flash frequency is 0.33Hz (flashing once every 3 seconds);
- When the communication is normal, the flash frequency is 2Hz (flashing twice every second);
- When the system is abnormal, the flash frequency is 10Hz (flashing 10 times every second);
- When hardware exception occurs, such as under voltage, hardware damage, pseudo soldering, and short circuit, the system indicator lamp is always on or off.
- For a Lambda 4S/5S series CNC system, when PC logical data or physical connection interrupted, the IO ports on the controller and the extended terminal board maintain their status.

## 1.9 Configuration

### 1.9.1 Lambda 3S/3L CNC System

- One communication card (PM85A or PM95A), or one NC65A/65B/65C host;
- One Lambda 3S/3L controller;
- One DB9M/F cable (Cable length customizable);
- Cables (DB15) connected to stepping drivers (Configured according to actual situations);
- One NcStudio motion control software CD (Not required if software customized);

- One NK-MPG-06 handwheel (Optional).

## 1.9.2 Lambda 4S/5S/5E/5M Series CNC System

- One communication card (PM85A or PM95A) or one NC65A/65B/65C or NK300BX host or NK300CX host;
- One Lambda 4S/5S/5E/5M controller;
- One NcStudio motion control software CD (not required if software customized);
- One DB9M/F cable (cable length customizable);
- M2 communication wires,
- One M2 terminal resistance(for Lambda 5M controller)
- One handwheel (optional, including NK-MPG-06, aviation plug handwheel NK-MPG-09 and EHDW-DA5S-1M).



- 1) For the info related to Lambda 4S controller used together with NK300BX, please refer to *NK300BX Integrated CNC System Manufacturers' Manual*.
- 2) The configuration specified in Section 1.9 is the standard one. Please make sure the configuration according to the delivery note.
- 3) Production of NK300BX has been ceased since October, 2016.

# 1.10 Overall Connection Diagram

Lambda 3S/3L/4S/5S/5E controllers are used in non-bus CNC system. Fig. 1-9 is an example of non-bus system connection with Lambda 4S controller. And bus system connection connection with Lambda 5M controller is as shown in Fig. 1-10.

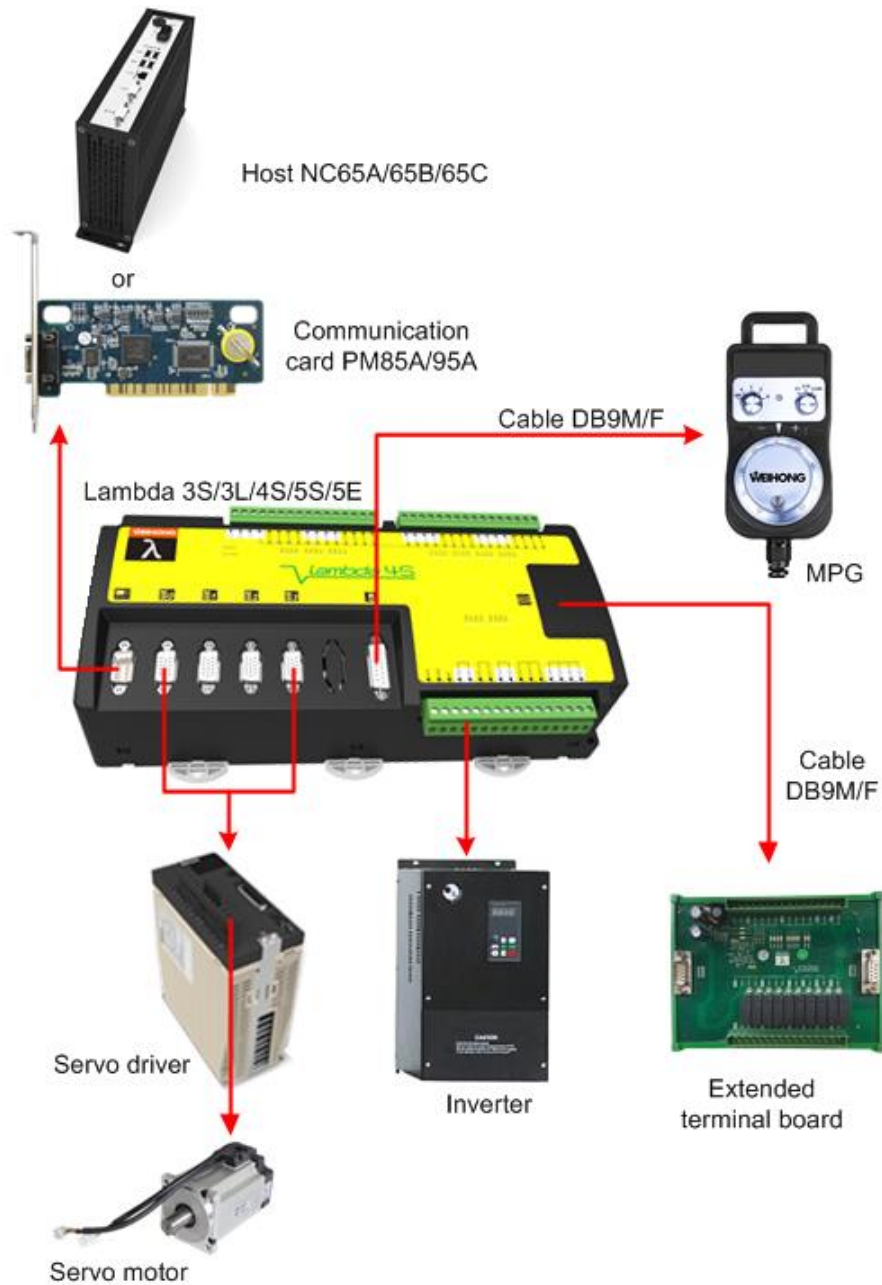

Fig. 1-9 Overall wiring diagram (non-bus system)

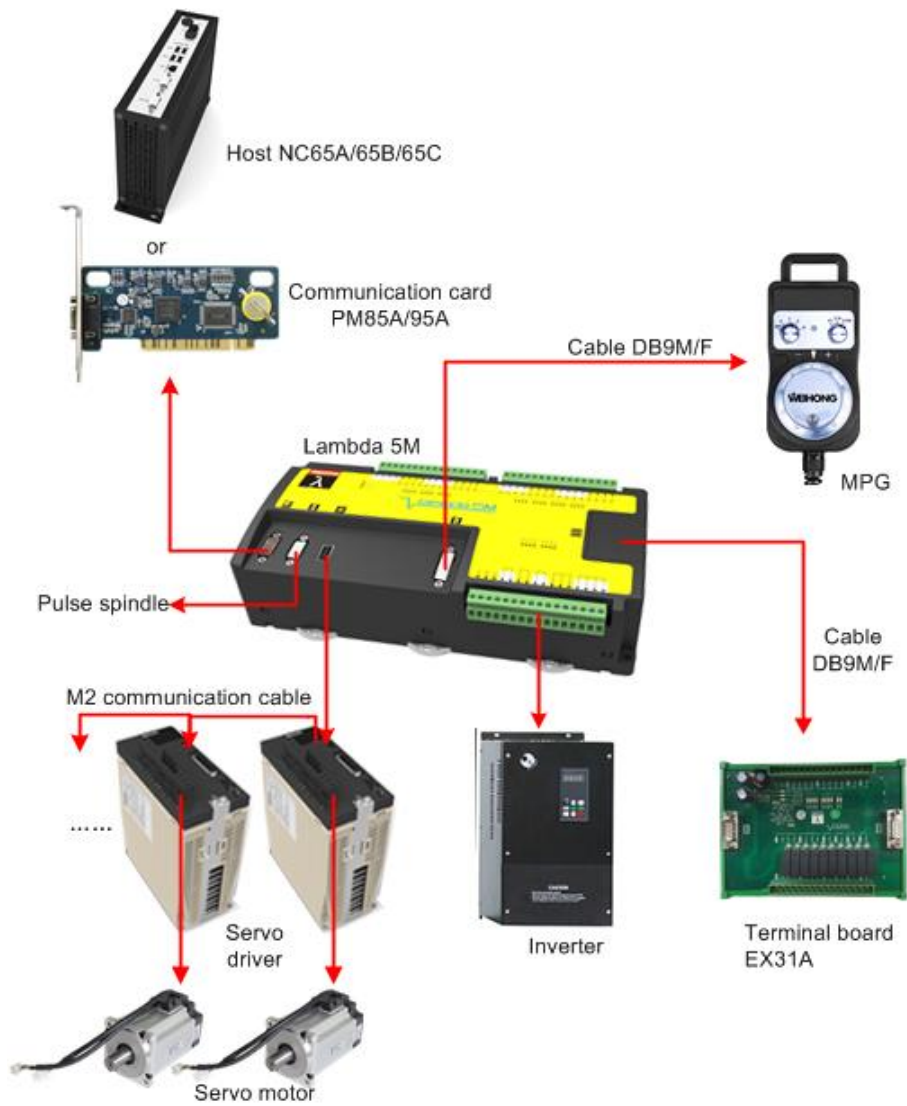

Fig. 1-10 Overall wiring diagram (bus system)



Please connect according to the actual situations. The above pictures are provided for reference only.

# 2 Wiring

## 2.1 Lambda 3S/3L Controller

Lambda series controllers are compatible with PNP and NPN switches, with inputs NO/NC and active high/low. When S is connected to COM, inputs are active high; when connected to +24V, active low.

The type of the power circuit of Lambda 3S/3L series circuit board is switching power supply, with overvoltage and under-voltage protection.

### 2.1.1 Wiring of Lambda 3S Controller

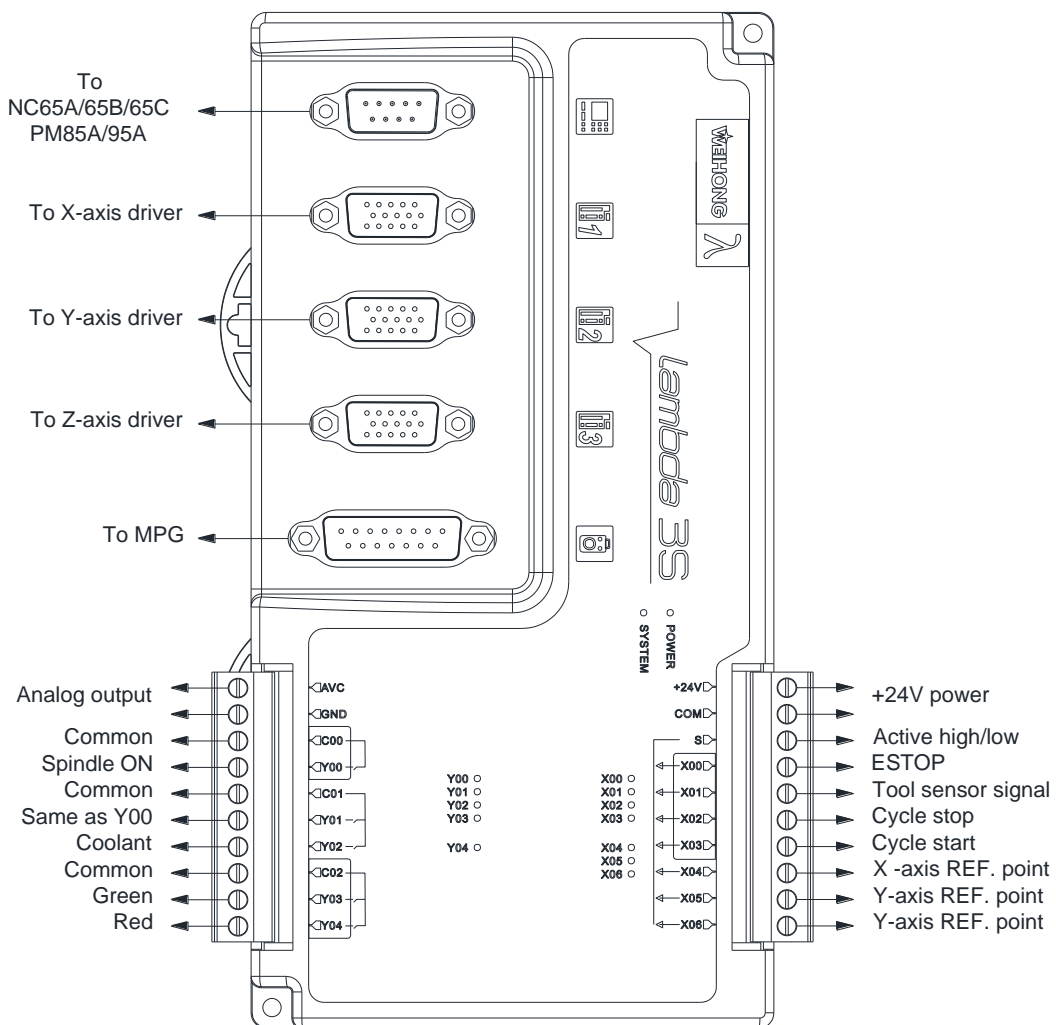

Fig. 2-1 Wiring of Lambda 3S controller



- 1) Except for no MPG interface, Lambda 3L controller has the same inputs and outputs as Lambda 3S.
- 2) The above wiring is standard, provided for reference only. Please refer to the specific software for IO definitions and IO wiring.
- 3) In system with Lambda 3S/3L controller, port Y01 synchronizes with port Y00.

## 2.1.2 Definitions of Inputs

There are altogether 7 inputs, with their definitions as follows:

Category	Port No.	Definition	Remark
External power supply	+24V	DC 24V power supply	Providing power supply for the controller.
	COM		
Inputs commonly used	X00	Emergency stop	Binary input, generally connected to a NC button.
	X01	Tool sensor signal	Binary input, connected to tool sensor signal.
	X02	Cycle stop	For external connection with an operating button.
	X03	Cycle start	For external connection with an operating button.
	X04	X-axis reference point	Binary input, connected to X-axis home switch.
	X05	Y-axis reference point	Binary input, connected to Y-axis home switch.
	X06	Z-axis reference point	Binary input, connected to Z-axis home switch.
Common	S	Common port of the above 7 input signals	When S is connected to COM, inputs are active high; when to +24V, active low.

## 2.1.3 Definitions of Outputs

The definitions of the outputs are as follows:

Category	Port No.	Definition	Remark
Spindle control	AVC	Analog voltage (0~10V) output signal	Controlling the rotary speed of spindle motor. It externally connects with the analog voltage frequency instruction input terminal of an inverter (generally known as AVI/VI) and controls spindle speed through voltage change causing frequency change of inverter.
	GND	Analog voltage ground	Connecting with analog ground of an inverter (generally known as ACM).
	Y00	Spindle on	Relay output.
Outputs commonly used	Y01	-	Synchronizing with Y00
	Y02	Coolant	Controlling coolant pump on/off.
	Y03	Green	Green lamp on when a machine tool is in normal working status.
	Y04	Red	Red lamp on when system E-stop occurs, also on as a reminder when machining ends regularly.
Common	C00	Common of Y00	
	C01	Common of Y01 and Y02	
	C02	Common of Y03 and Y04	



## 2.2 Lambda 4S/5S/5E/5M Controller

The normal working range of Lambda 4S/5S/5E/5M controller is 17V~30V, and the rated voltage is 24V. When the voltage difference between power voltage and the Common S is over 8V, the input connection becomes effective. The inputs of Lambda 4S/5S/5E/5M controller can be active high/low, so can the extended terminal board. When Common S is connected to COM, inputs are active high; when to +24V, active low.



The wirings below are for the general software for the time being, provided for reference only. Please refer to the specific software for definitions and wiring of input and output ports.

### 2.2.1 Wring in Engraving and Milling software

See this section for the wiring diagrams of controller for three to five axis engraving and milling machines.

For three-axis and four-axis engraving and milling system, Lambda 4S controller is used. When IOs are not enough, you can choose extended terminal board EX27A.

For non-bus five-axis engraving and milling system, Lambda 5S controller is used. When IOs are not enough, you can choose extended terminal board EX31A. In addition, if encoder feedback function is required, choose Lambda 5E controller.

**2.2.1.1 Three-axis Configurations in Engraving and Milling Software**

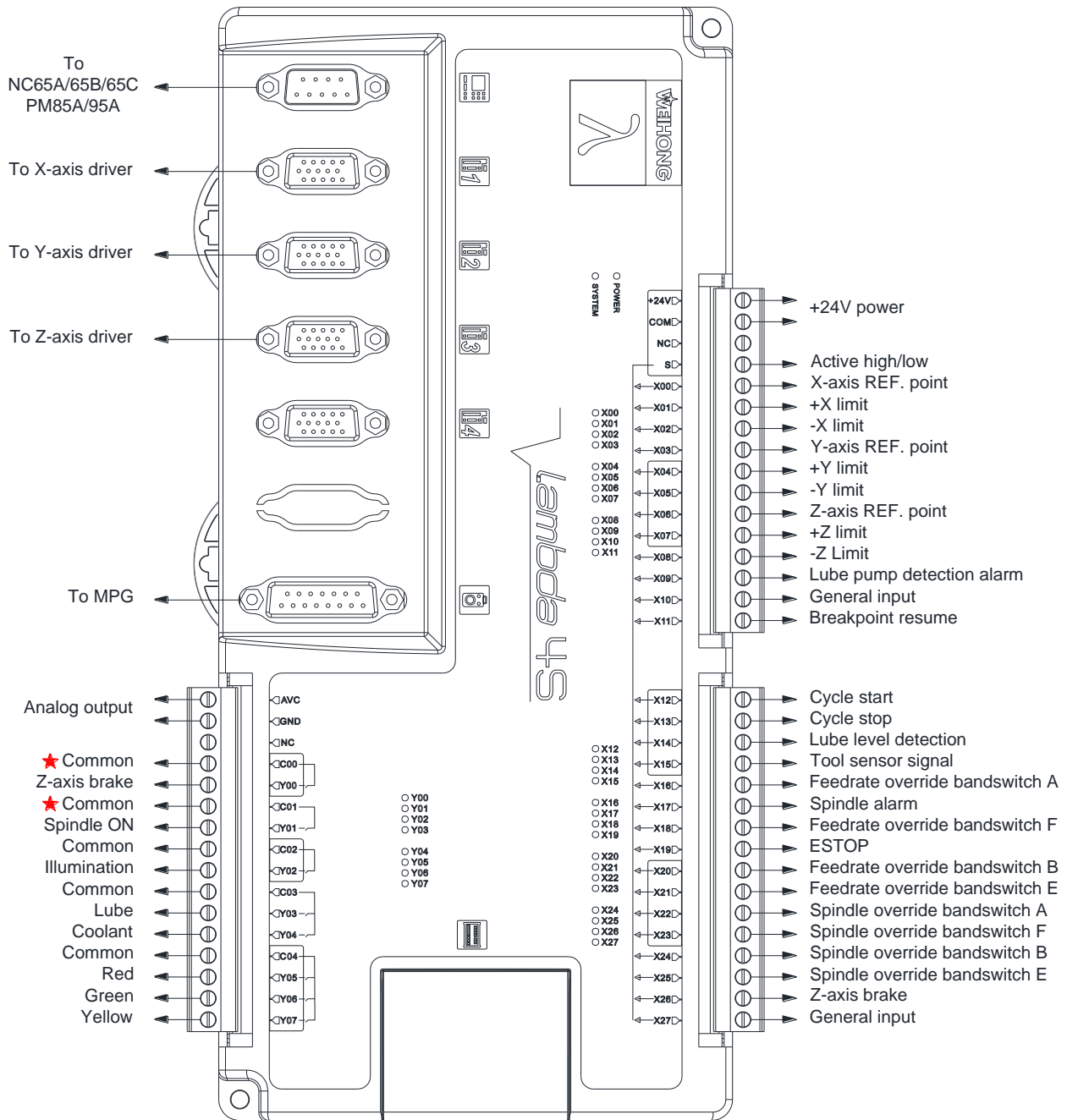

Fig. 2-2 Wiring according to three-axis standard configuration according to engraving and milling software



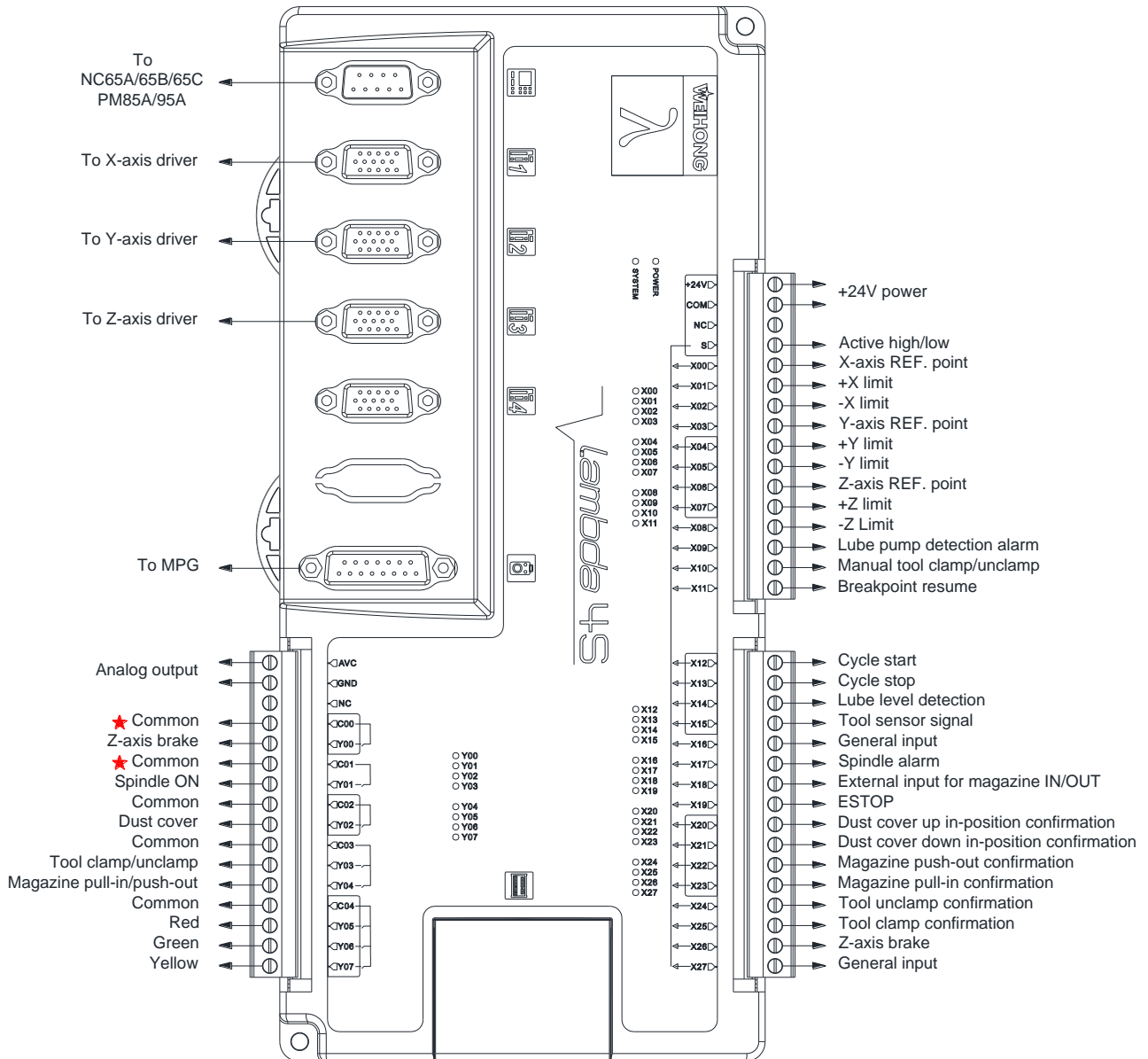

Fig. 2-4 Wiring according to three-axis linear tool magazine configuration according to engraving and milling software



- 1) For Lambda 4S/5S controller, C00 is the common of Y00, C01 the common of Y01, C02 the common of Y02, C03 the common of Y03 and Y04, and C04 the common of Y05, Y06 and Y07.
- 2) Terminals Y00/C00 and Y01/C01 (marked with ★ in the wiring diagrams below) on Lambda 4S/5S controller should only be connected with load of voltage lower than or equal to 24V, otherwise, they will be damaged and cannot work due to burn-out of the piezoresistor, since a protective circuit is added to them for brake function (for serial connection with 24V motor brake coil).

### 2.2.1.2 Four-axis Configuration in Engraving and Milling Software

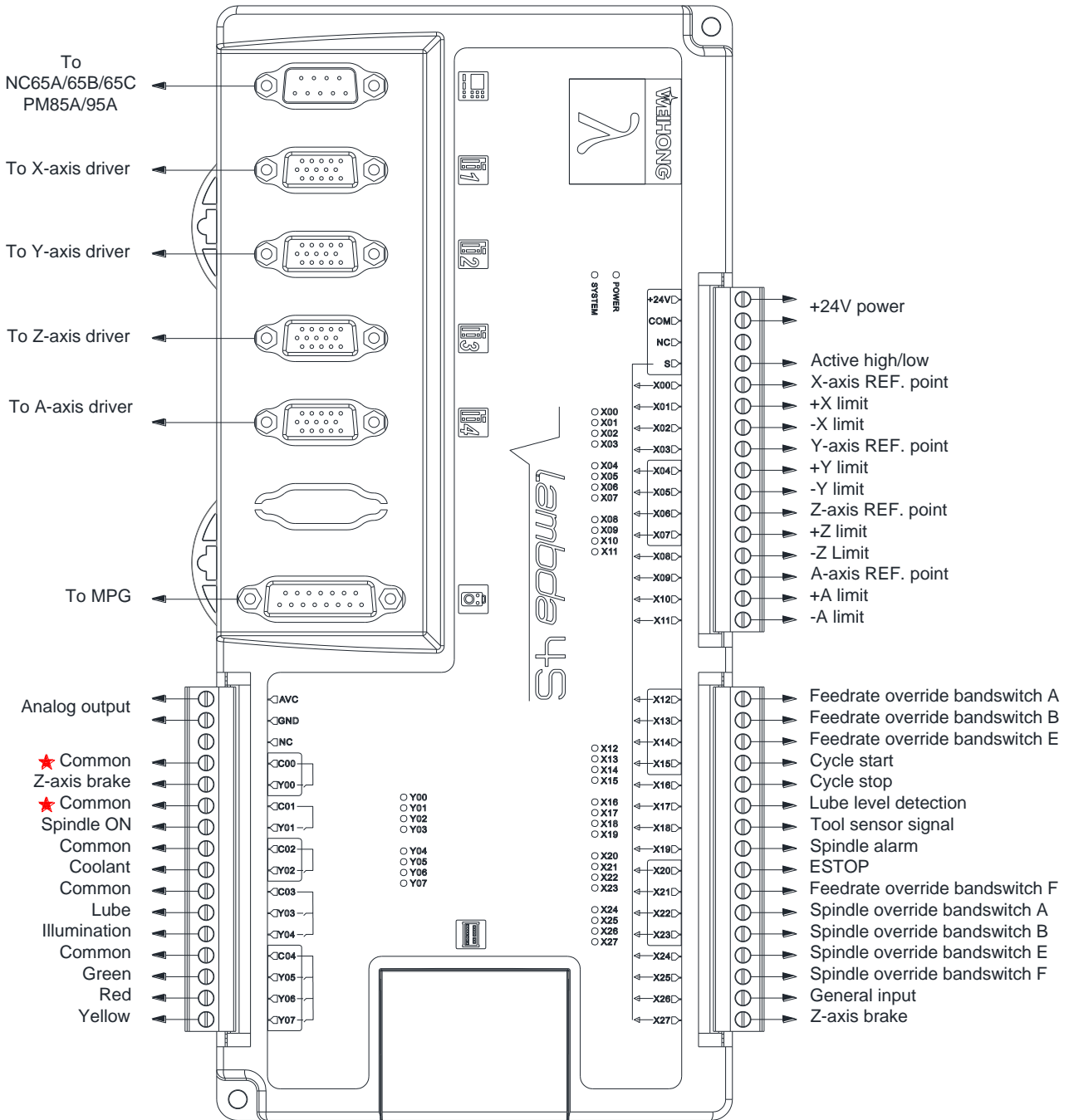

Fig. 2-5 Wiring according to four-axis configuration according to engraving and milling software



You can decided whether to connect input ports of feedrate override band switch and spindle override band switch according to the actual situation.

**2.2.1.3 Five-axis AC Configuration in Engraving and Milling Software**

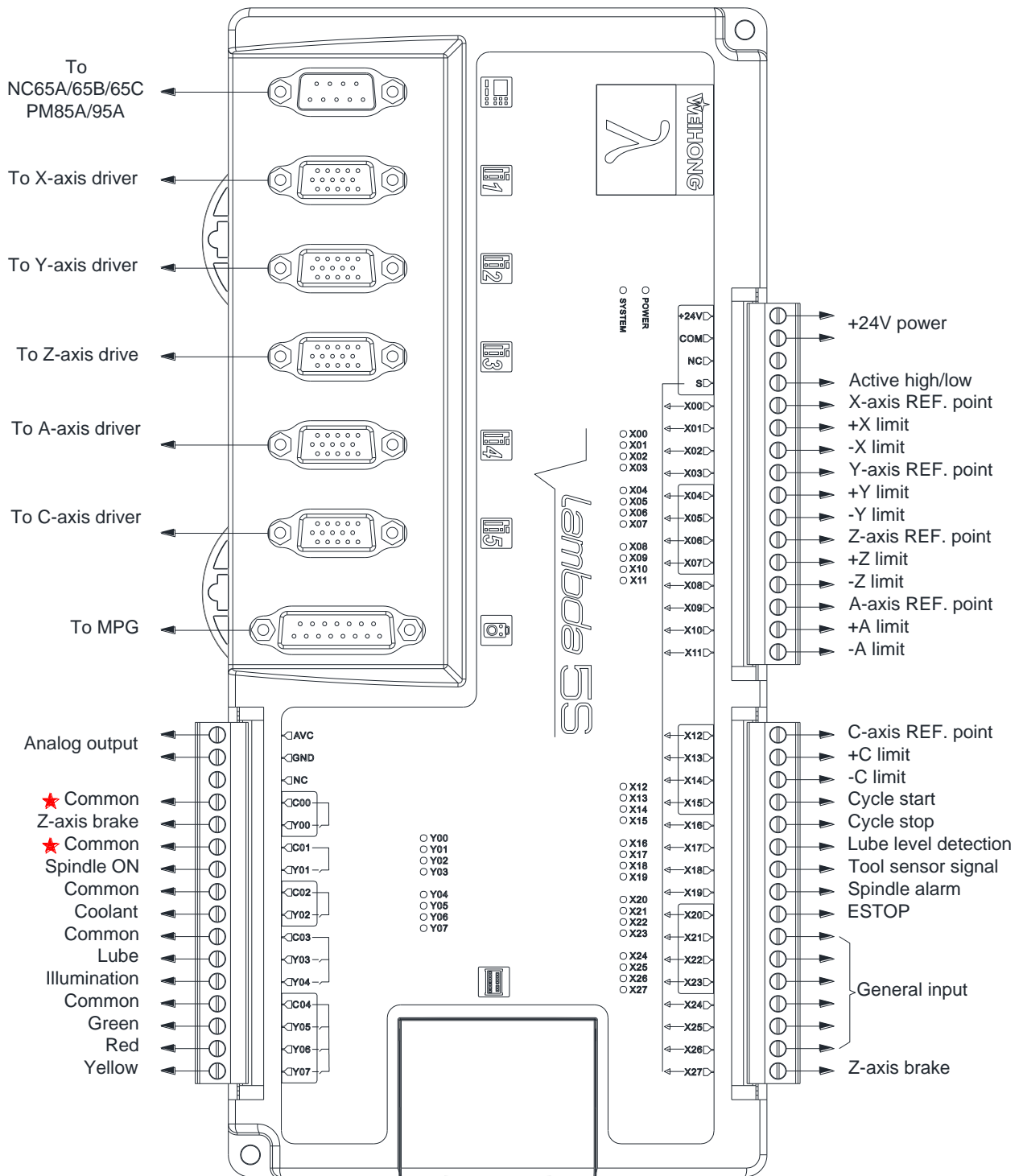

Fig. 2-6 Wiring according to five-axis AC configuration according to engraving and milling software

For AB and BC configuration, the definitions of inputs and outputs are the same as those in AC configuration, except X9~X14 are defined as REF. point and upper and lower limits of AB/BC axes respectively.

## 2.2.2 Wiring in Glass Cutting Software

Glass cutting software includes five kinds of configuration—XYA config, XYZA config, X1YAX2 config, XYA no edge config and XYZA no edge config.

### 2.2.2.1 XYA Configuration in Glass Cutting Software

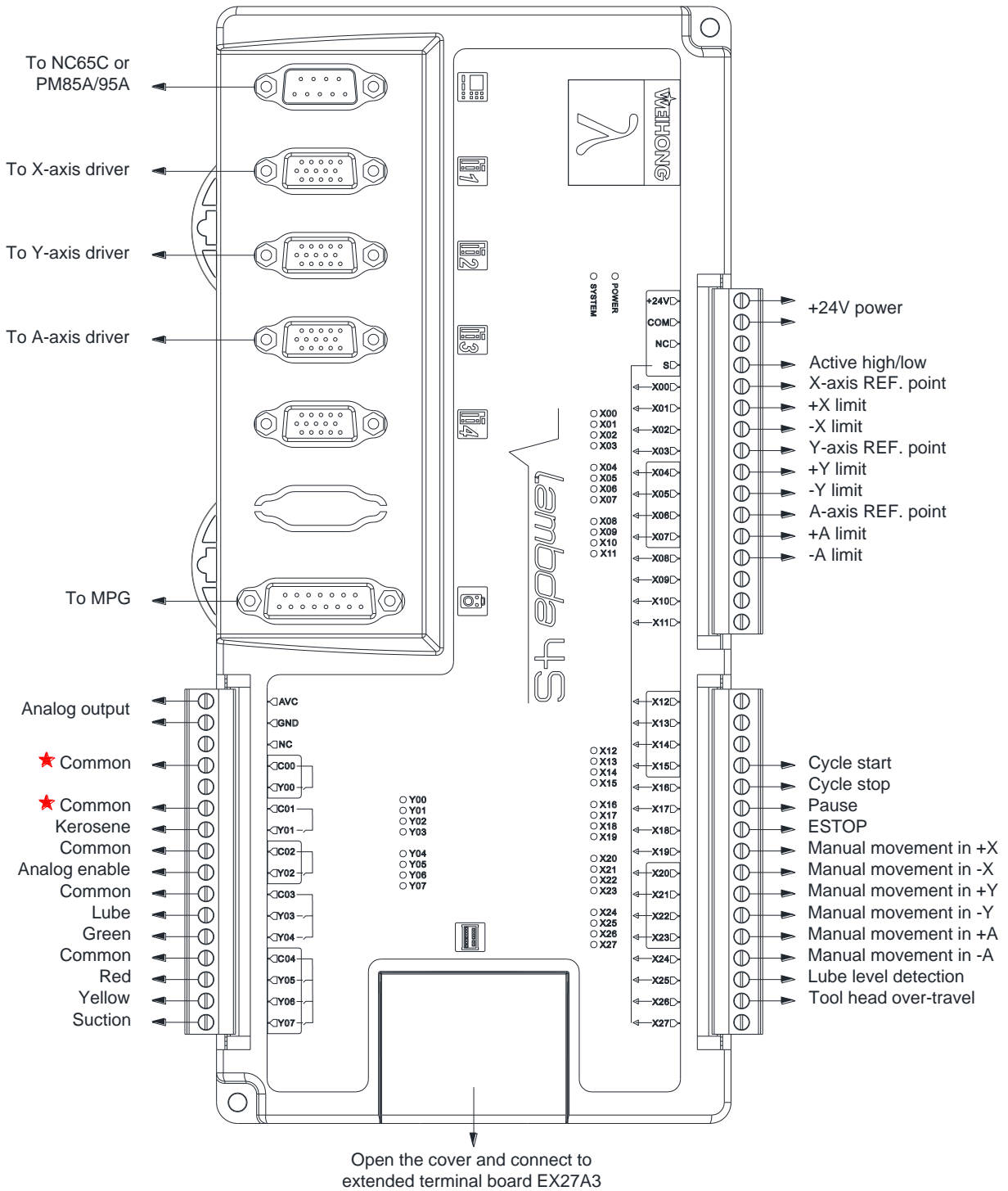

Fig. 2-7 Wiring according to XYA configuration according to glass cutting software

The extended terminal board EX27A3 (118mm\*83mm\*56.45mm) is required in XYA configuration. See Fig. 2-8 for the I/O definition and wiring diagram.

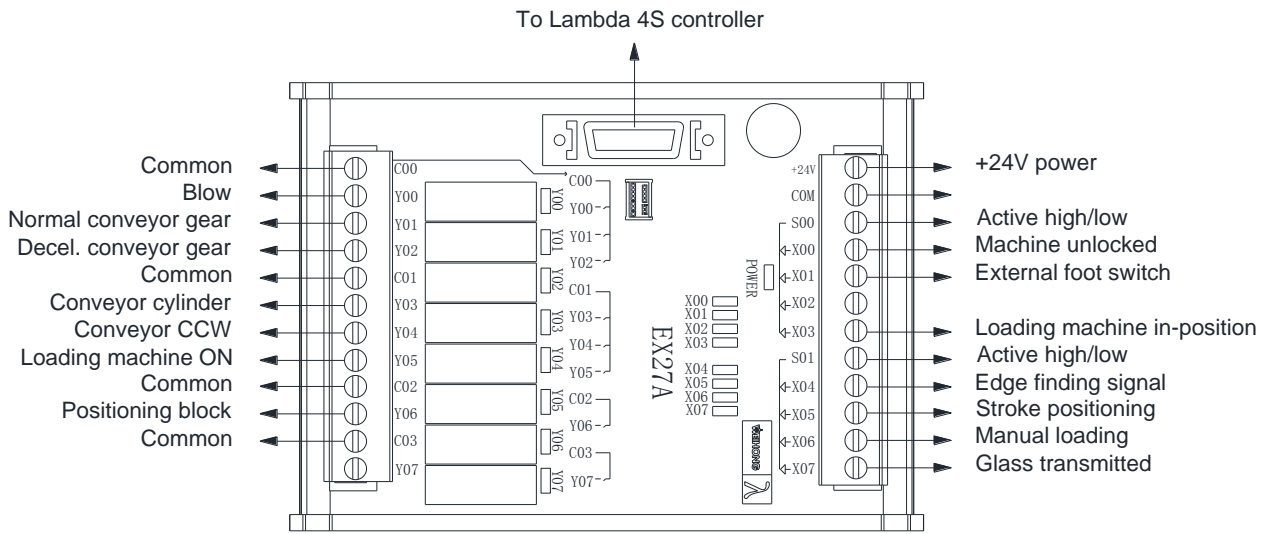

Fig. 2-8 Wiring example of EX27A3 according to XYA configuration according to glass cutting software



### 2.2.2.2 XYZA Configuration in Glass Cutting Software

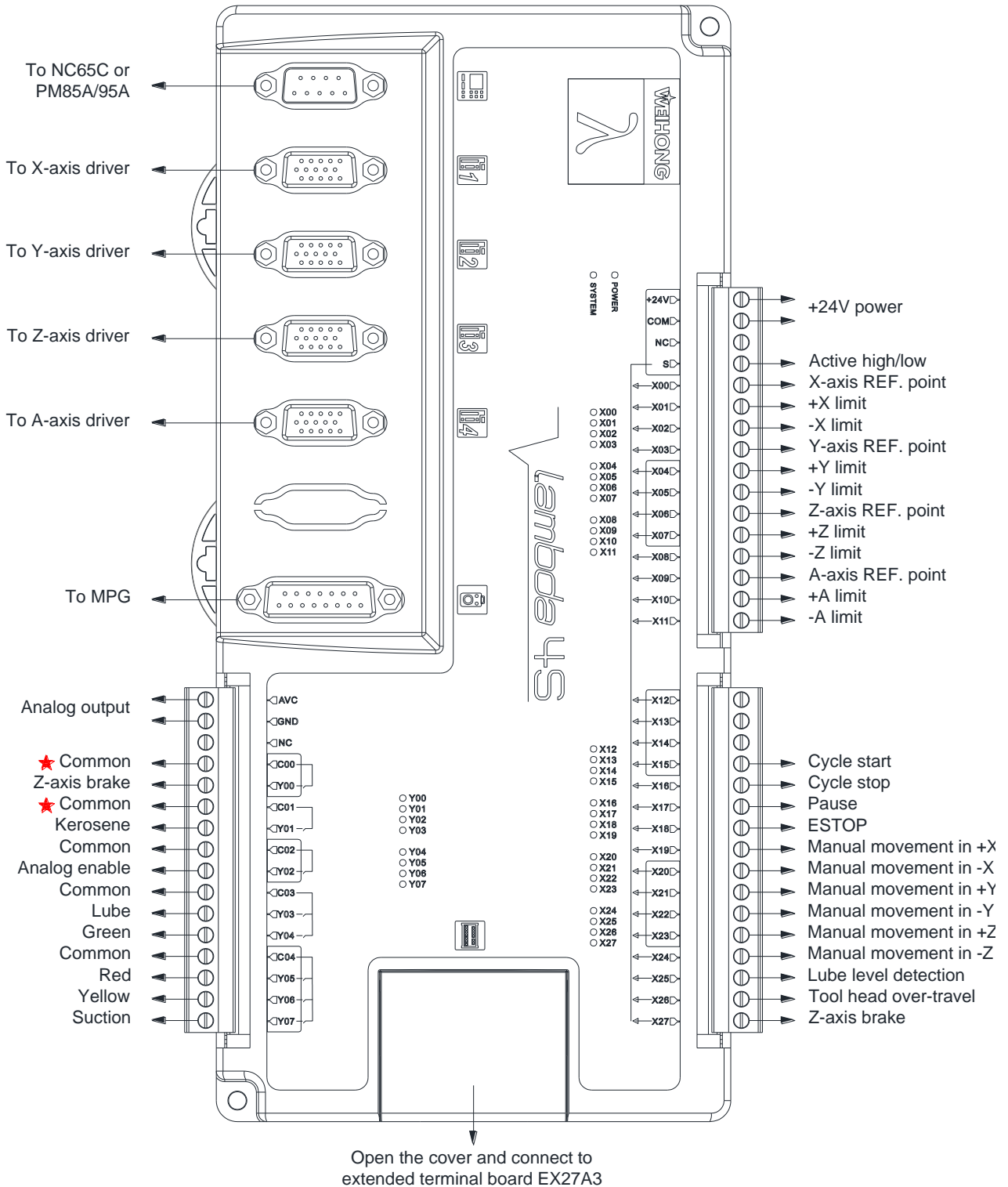

Fig. 2-9 Wiring according to XYZA configuration according to glass cutting software

The extended terminal board EX27A3 (118mm\*83mm\*56.45mm) is required in XYZA configuration. See Fig. 2-10 for the I/O definition and wiring diagram.

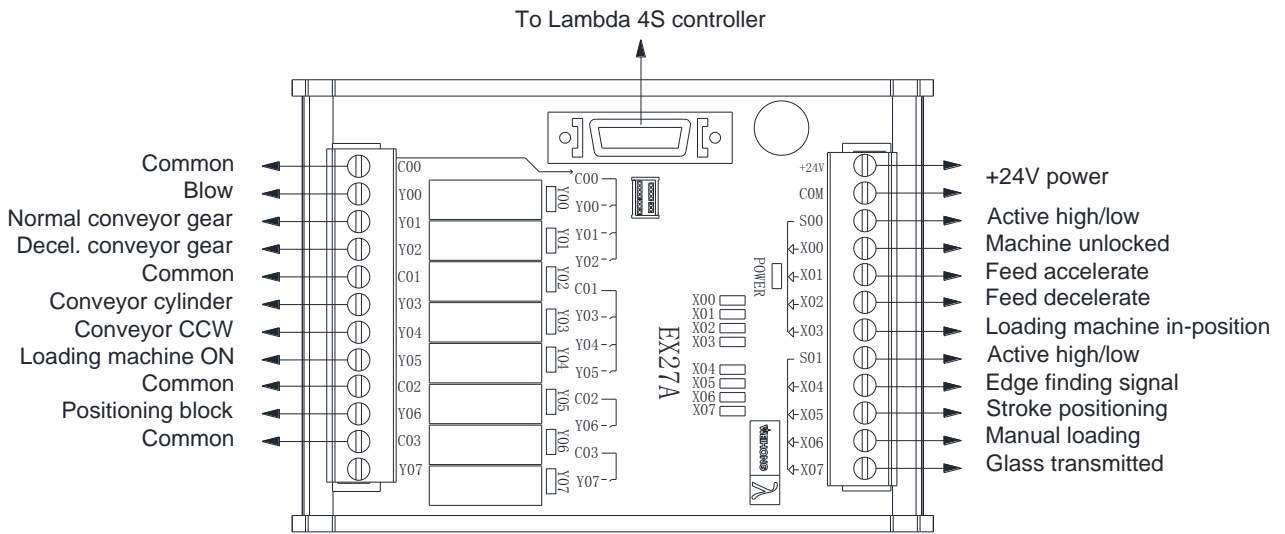

Fig. 2-10 Wiring example of EX27A3 according to XYZA configuration according to glass cutting software

### 2.2.2.3 X1YAX2 Config in Glass Cutting Software

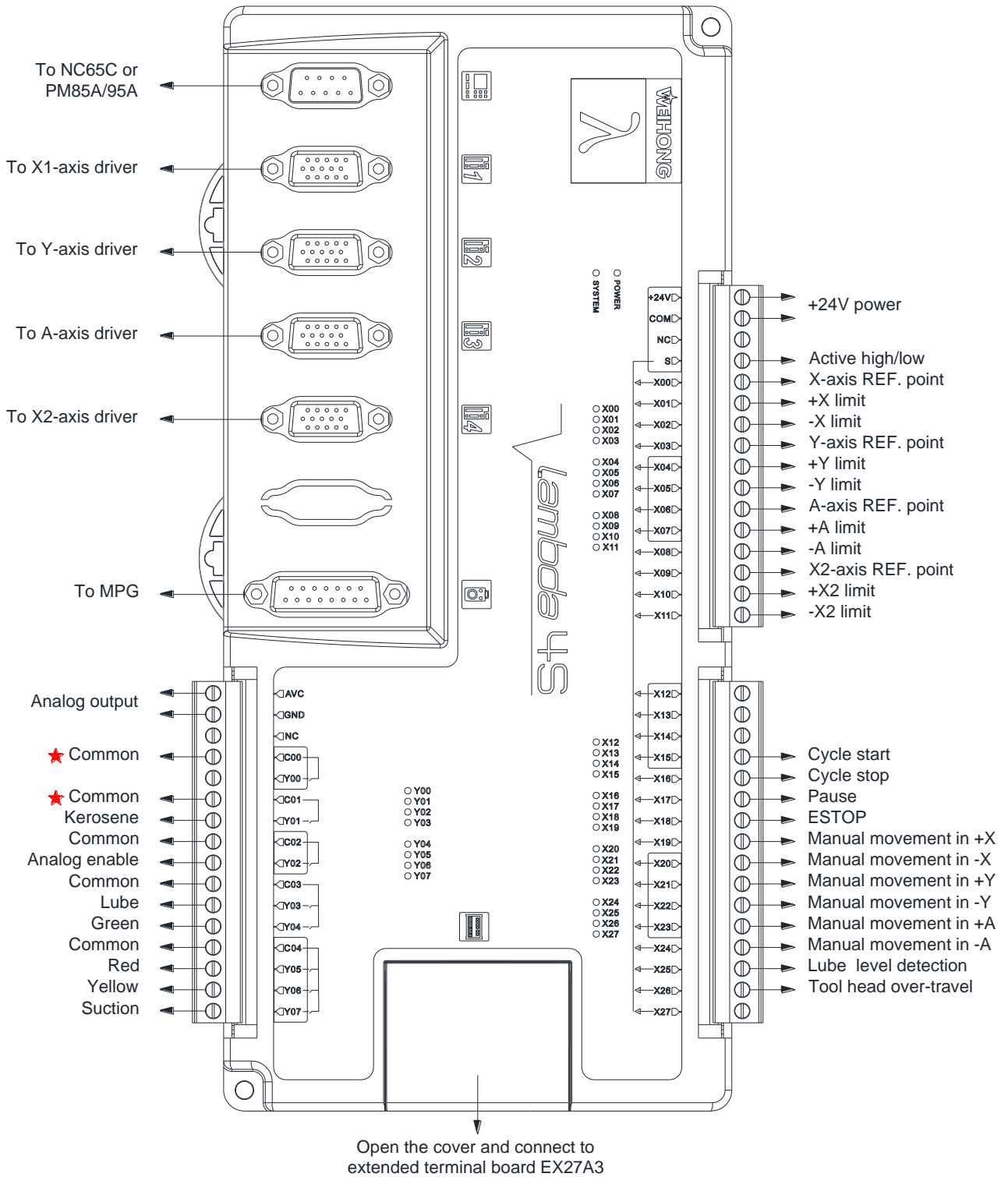

Fig. 2-11 Wiring according to X1YAX2 configuration according to glass cutting software

The extended terminal board EX27A3 (118mm\*83mm\*56.45mm) is required in X1YAX2 configuration. See Fig. 2-12 for the I/O definition and wiring diagram.

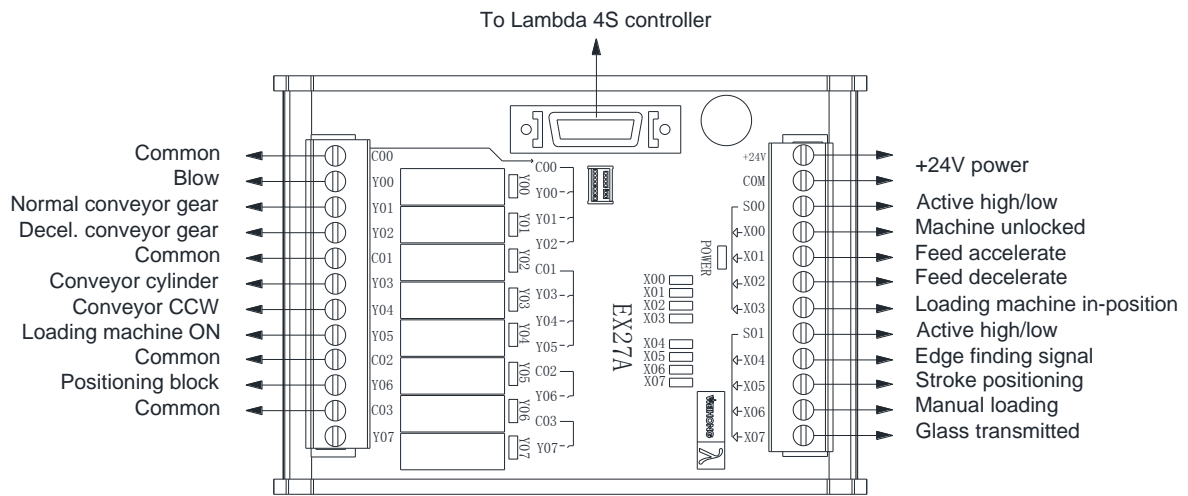

Fig. 2-12 Wiring example of EX27A3 according to X1YAX2 configuration according to glass cutting software

### 2.2.2.4 XYA No Edge Configuration in Glass Cutting Software

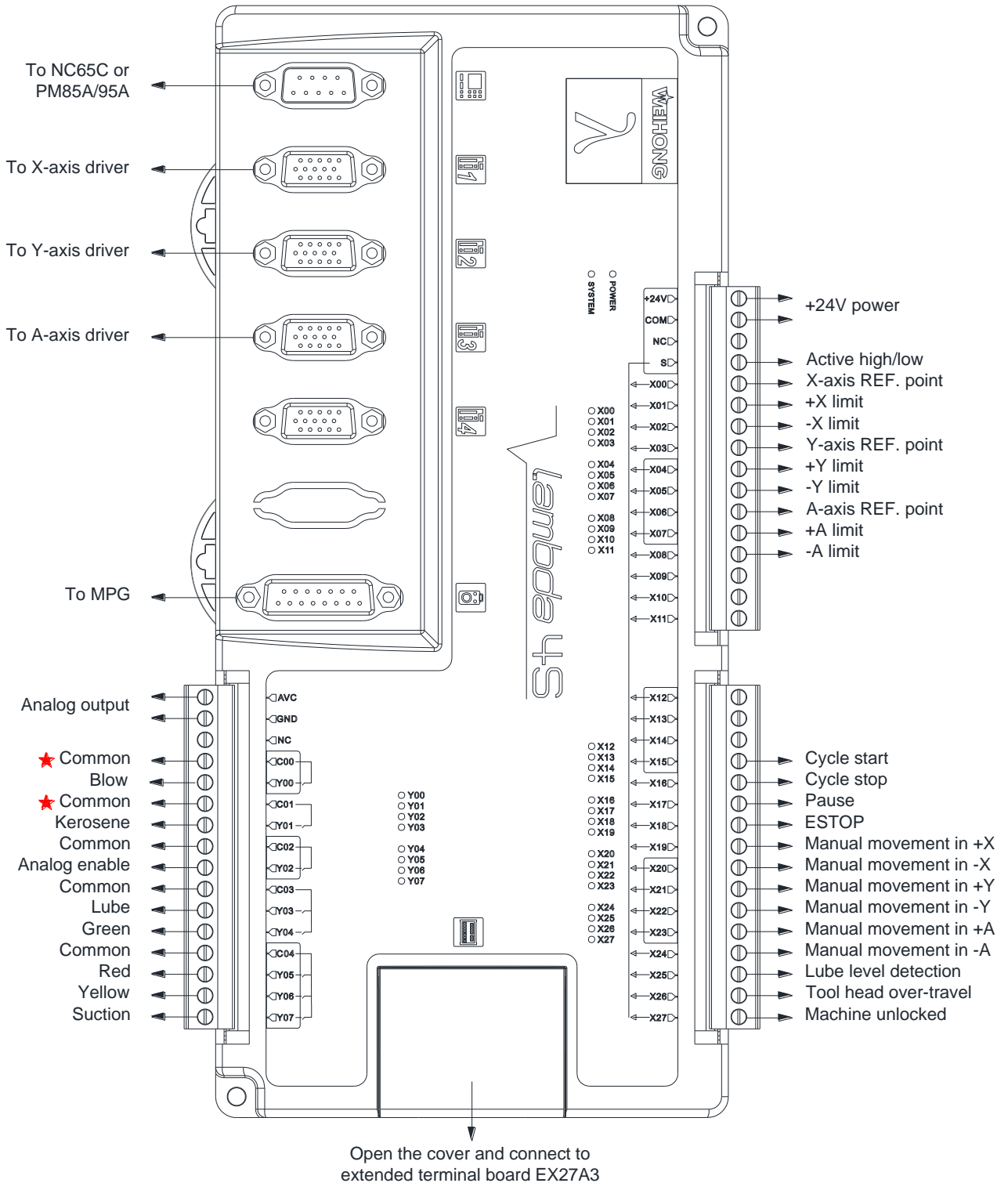

Fig. 2-13 Wiring according to XYA no edge configuration according to glass cutting software

**2.2.2.5 XYZA No Edge Config in Glass Cutting Software**

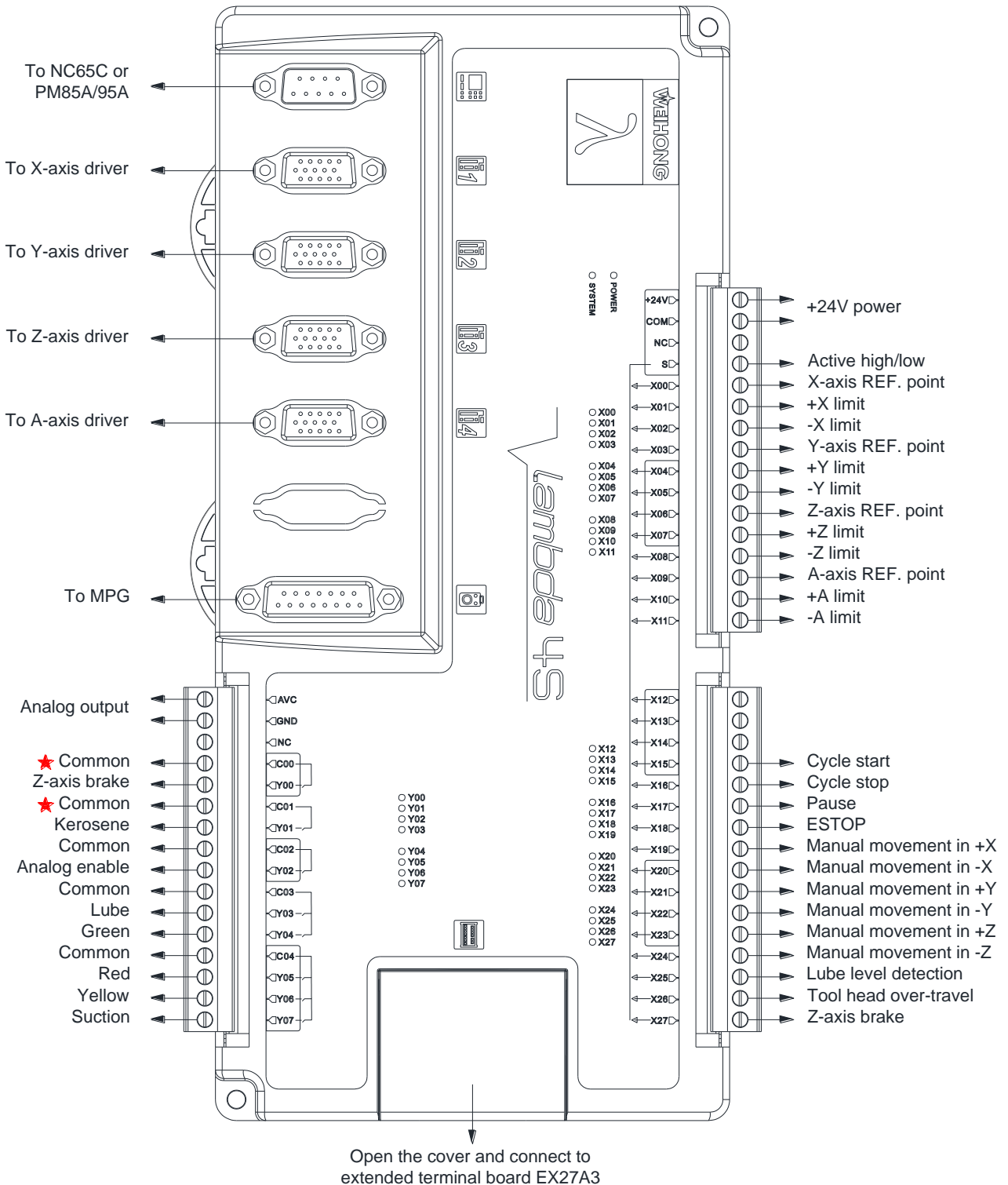

Fig. 2-14 Wiring according to XYZA no edge configuration according to glass cutting software



Extended terminal board EX27A is not required if XYZA no edge configuration is selected in Glass Cutting software.

### **2.2.3 Wiring in Waterjet Cutting Software**

For two-axis and three-axis waterjet cutting machines, Lambda 4S controller and extended terminal board EX27A are required. For four-axis and five-axis waterjet cutting machines, Lambda 5S controller and extended terminal board EX31A are required.

**2.2.3.1 XY1Y2 Configuration in Waterjet Cutting Software**

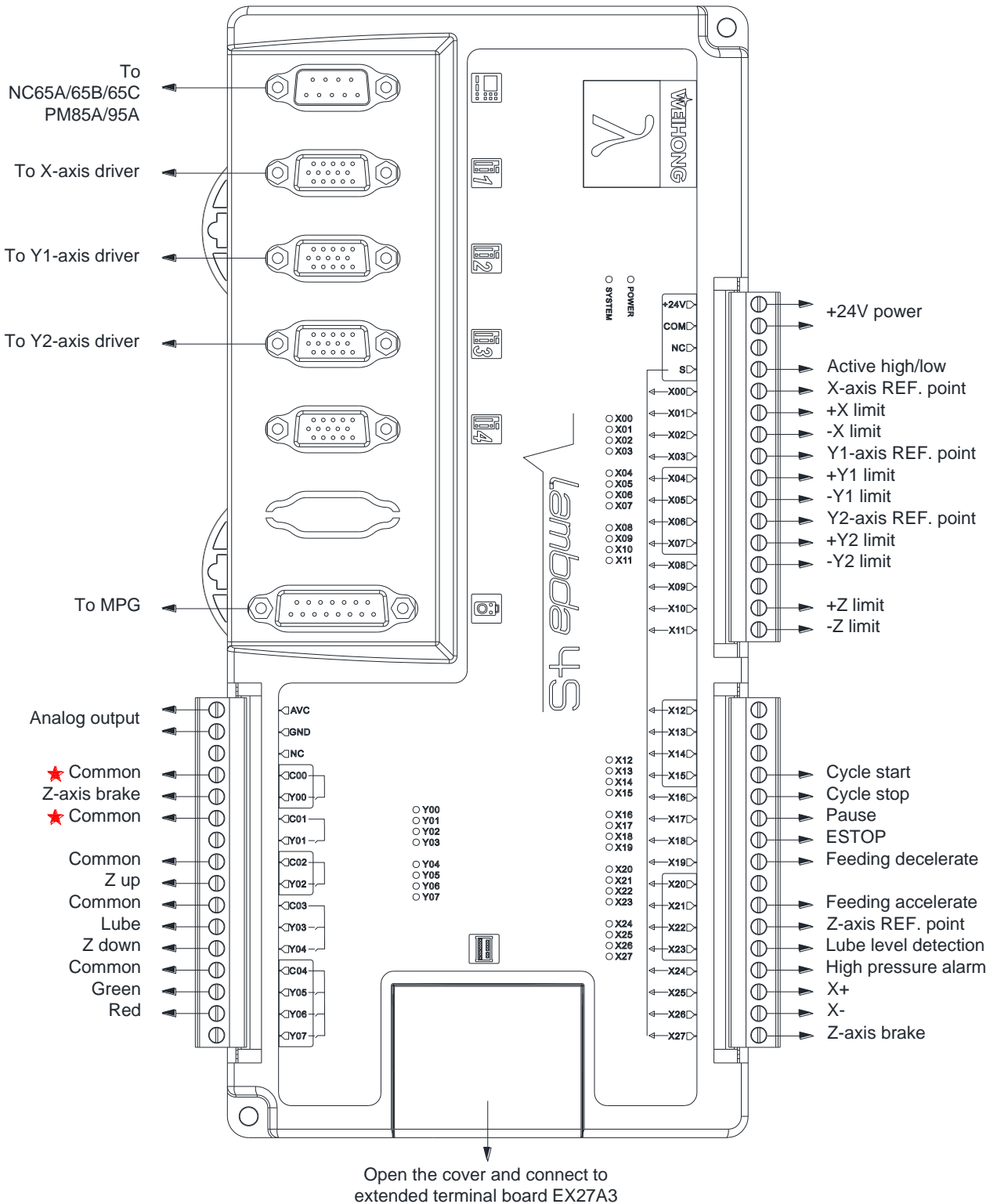

Fig. 2-15 Wiring according to XY1Y2 configuration according to waterjet cutting software



The extended terminal board EX27A (118mm\*83mm\*56.45mm) is required in XY1Y2 configuration, with wiring as shown in Fig. 2-16.

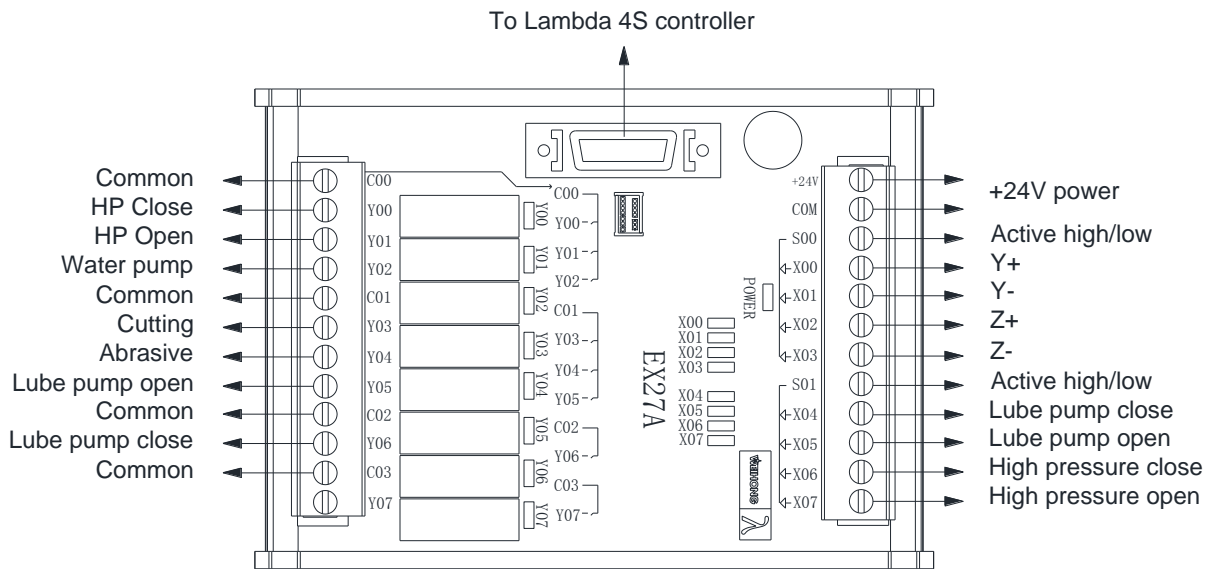

Fig. 2-16 Wiring of EX27A according to XY1Y2 configuration according to waterjet cutting software



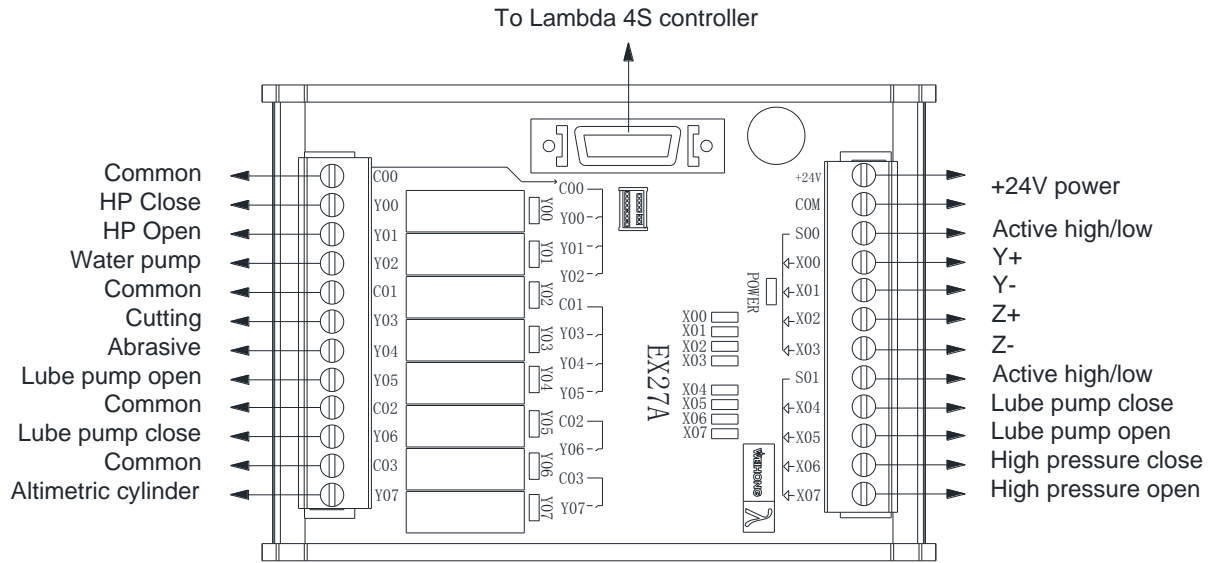

Fig. 2-18 Wiring of EX27A according to XYIZY2 configuration according to waterjet cutting software

Four-axis waterjet cutting software includes four configurations—XYC, XY1CY2, XYZC and XY1ZCY2.

**2.2.3.3 XYC Configuration in Waterjet Cutting Software**

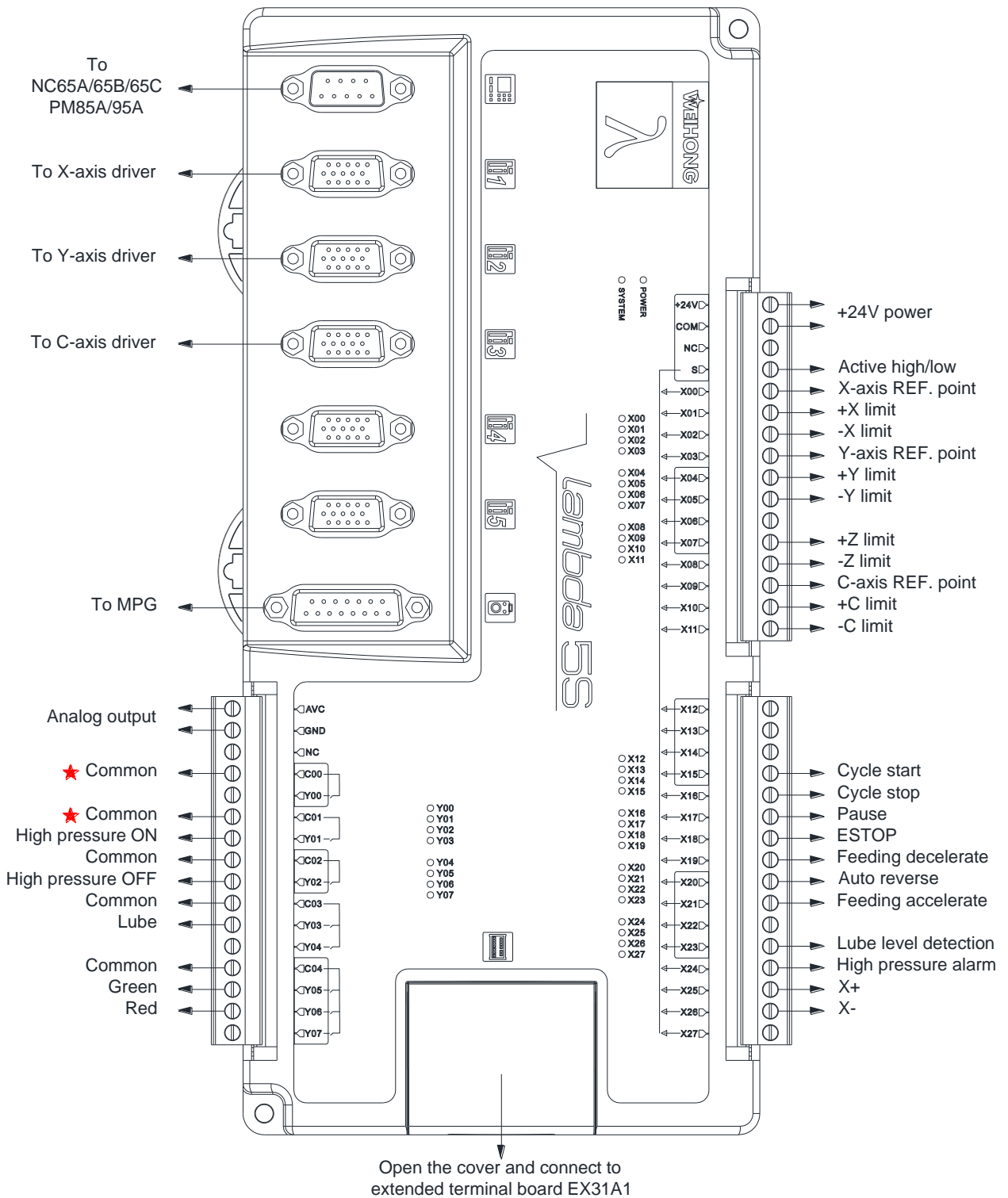

Fig. 2-19 Wiring according to XYC configuration according to waterjet cutting software

The extended terminal board EX31A1 (153mm\*118mm\*56.45mm) is required in XYC configuration, with wiring as shown in Fig. 2-20.

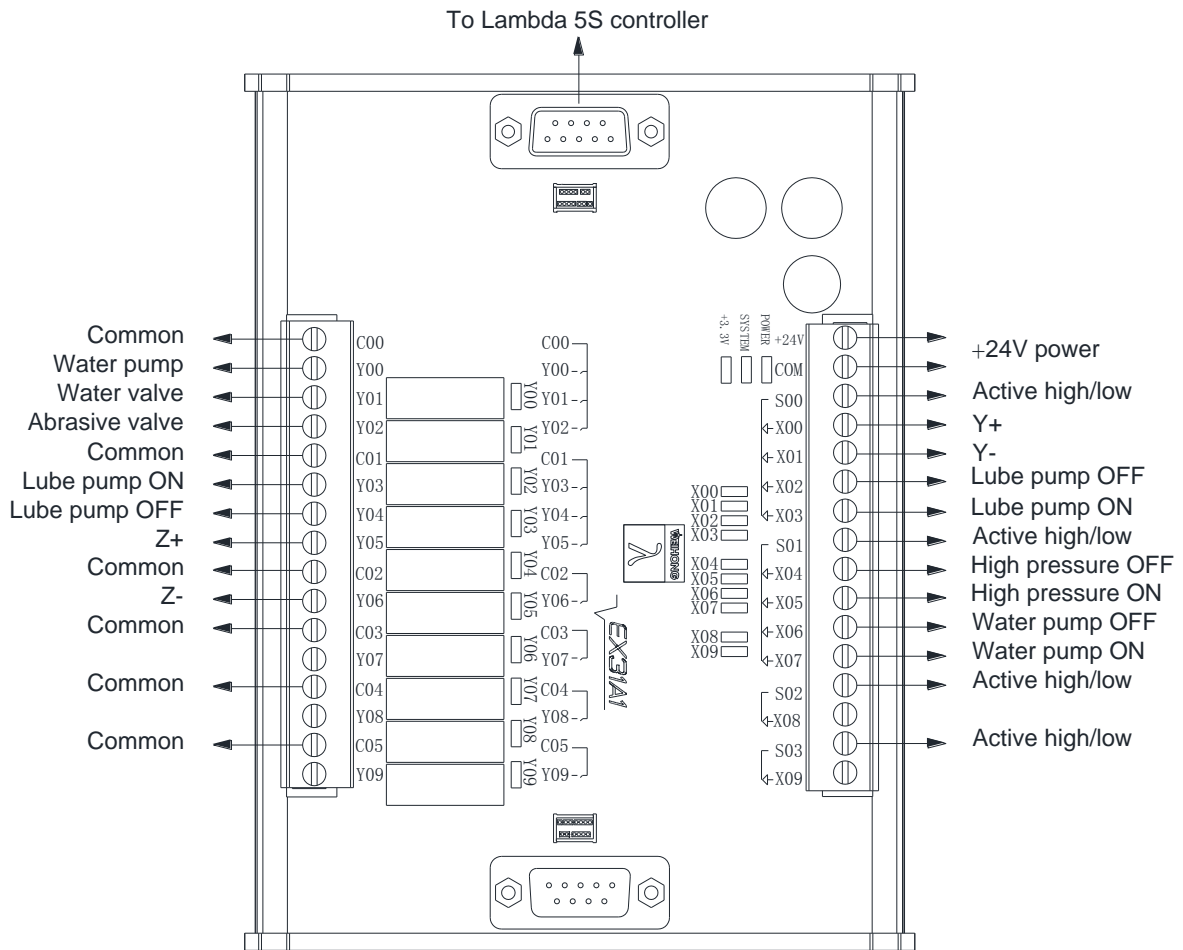

Fig. 2-20 Wiring of EX31A1 according to XYC configuration according to waterjet cutting software



For terminal board EX31A1, C00 is the common of Y00, Y01 and Y02, C01 the common of Y03, Y04 and Y05, C02 the common of Y06, C03 the common of Y07, C04 the common of Y08, and C05 the common of Y09.

**2.2.3.4 XY1CY2 Configuration in Waterjet Cutting Software**

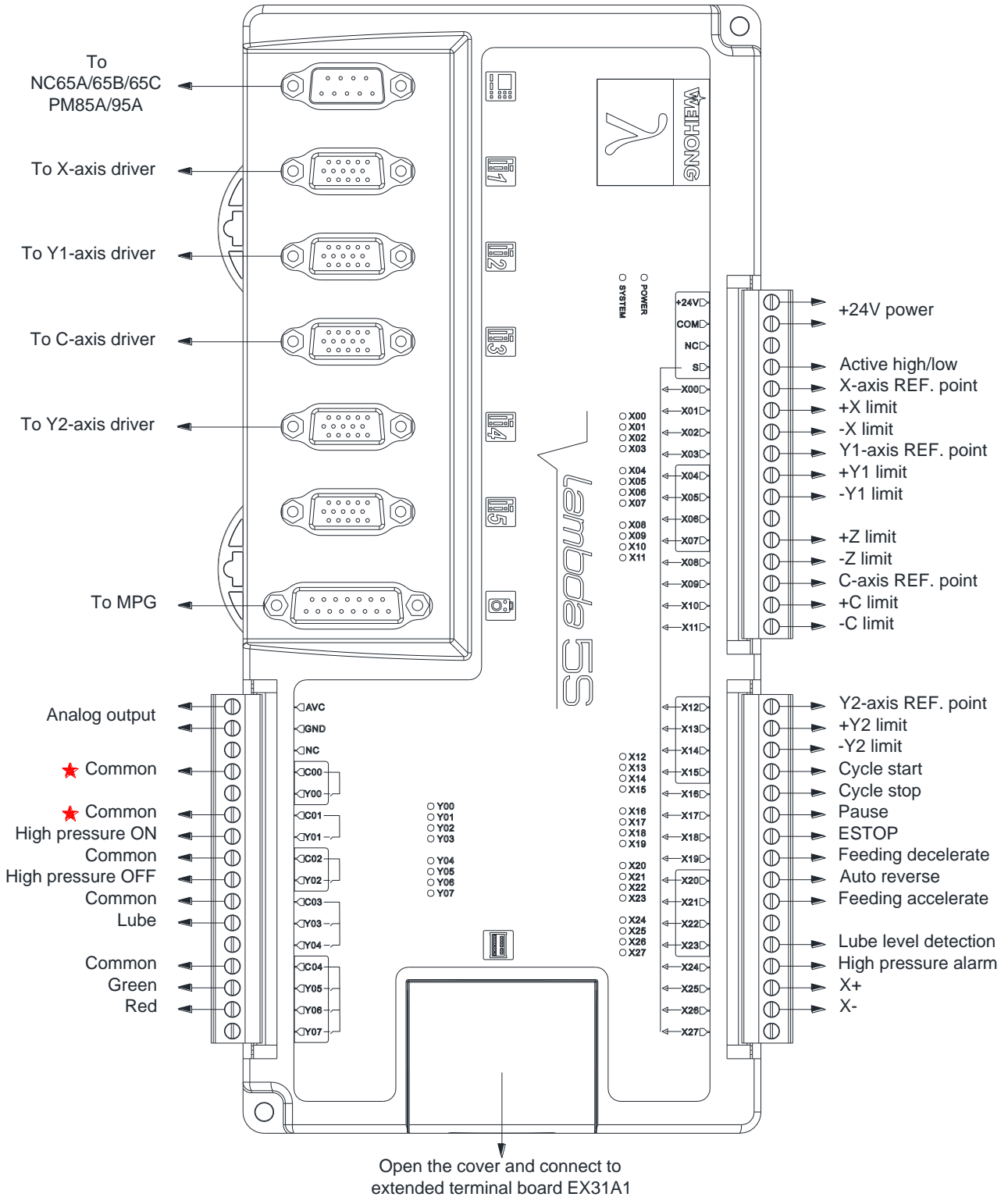

Fig. 2-21 Wiring according to XY1CY2 configuration according to waterjet cutting software

The extended terminal board EX31A1 (153mm\*118mm\*56.45mm) is required in XY1CY2 configuration, with wiring as shown in Fig. 2-22.

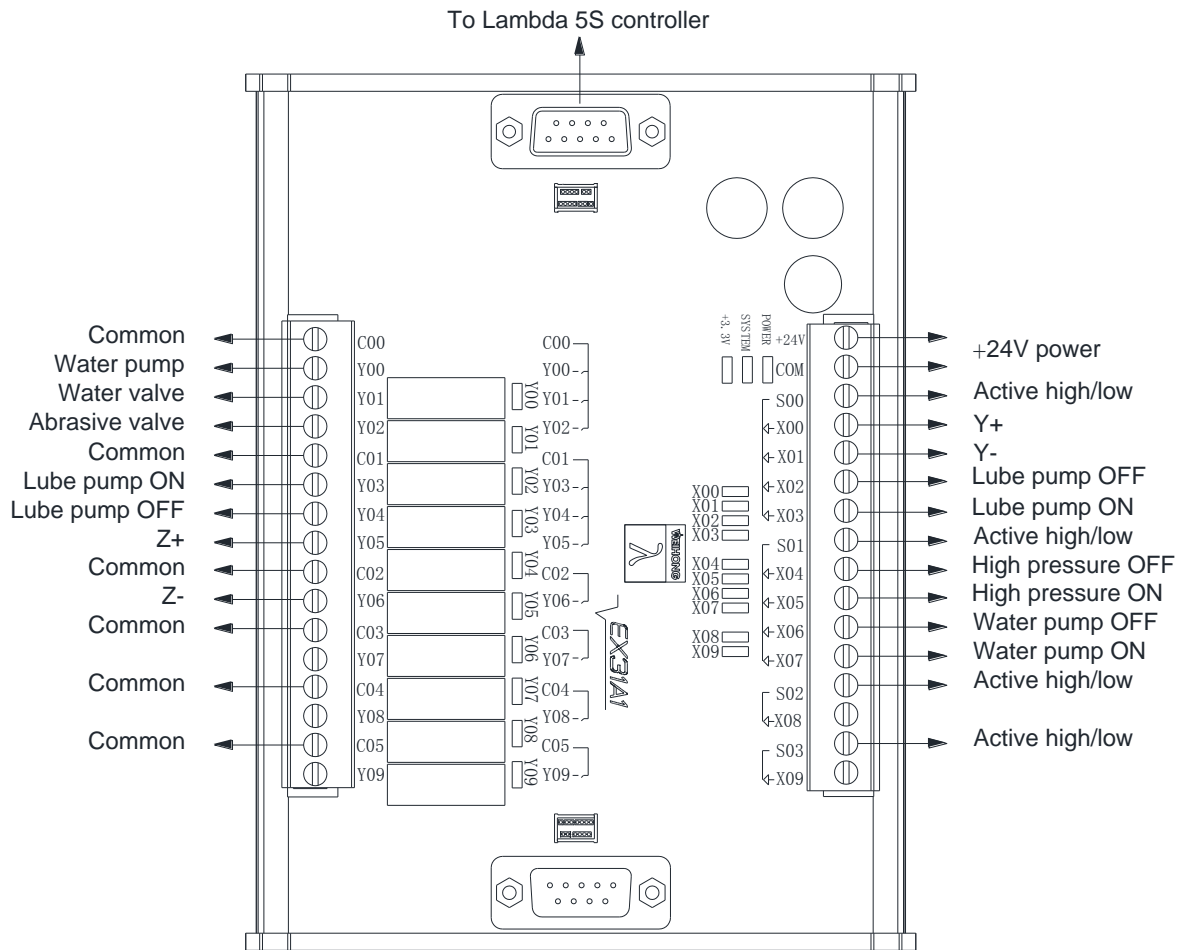

Fig. 2-22 Wiring example of EX31A1 according to XY1CY2 configuration according to waterjet cutting software

**2.2.3.5 XYZC Configuration in Waterjet Cutting Software**

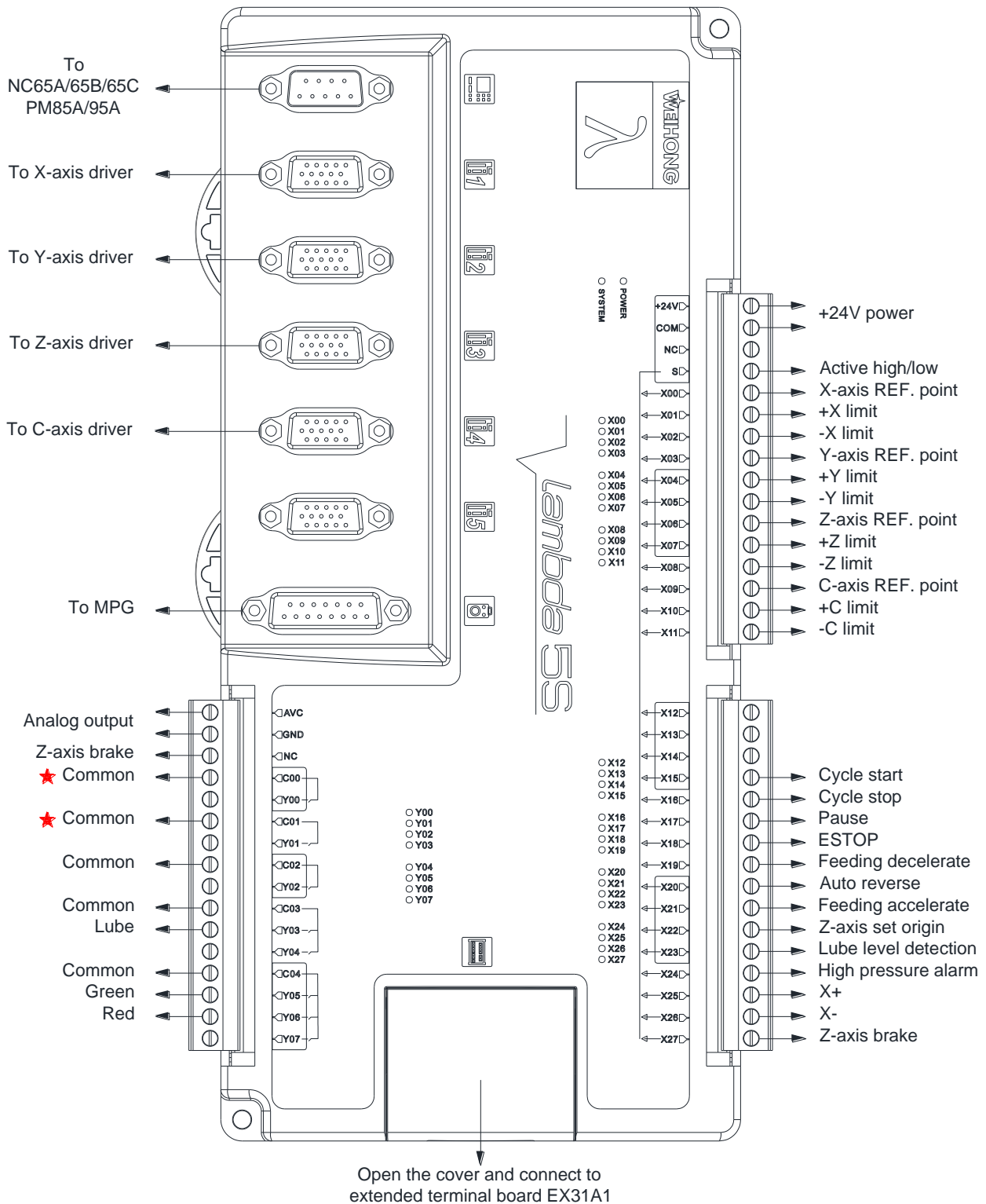

Fig. 2-23 Wiring according to XYZC configuration according to waterjet cutting software

Two pieces of extended terminal board EX31A1 (153mm\*118mm\*56.45mm) are required in XYZC configuration, with wiring as shown in Fig. 2-24.



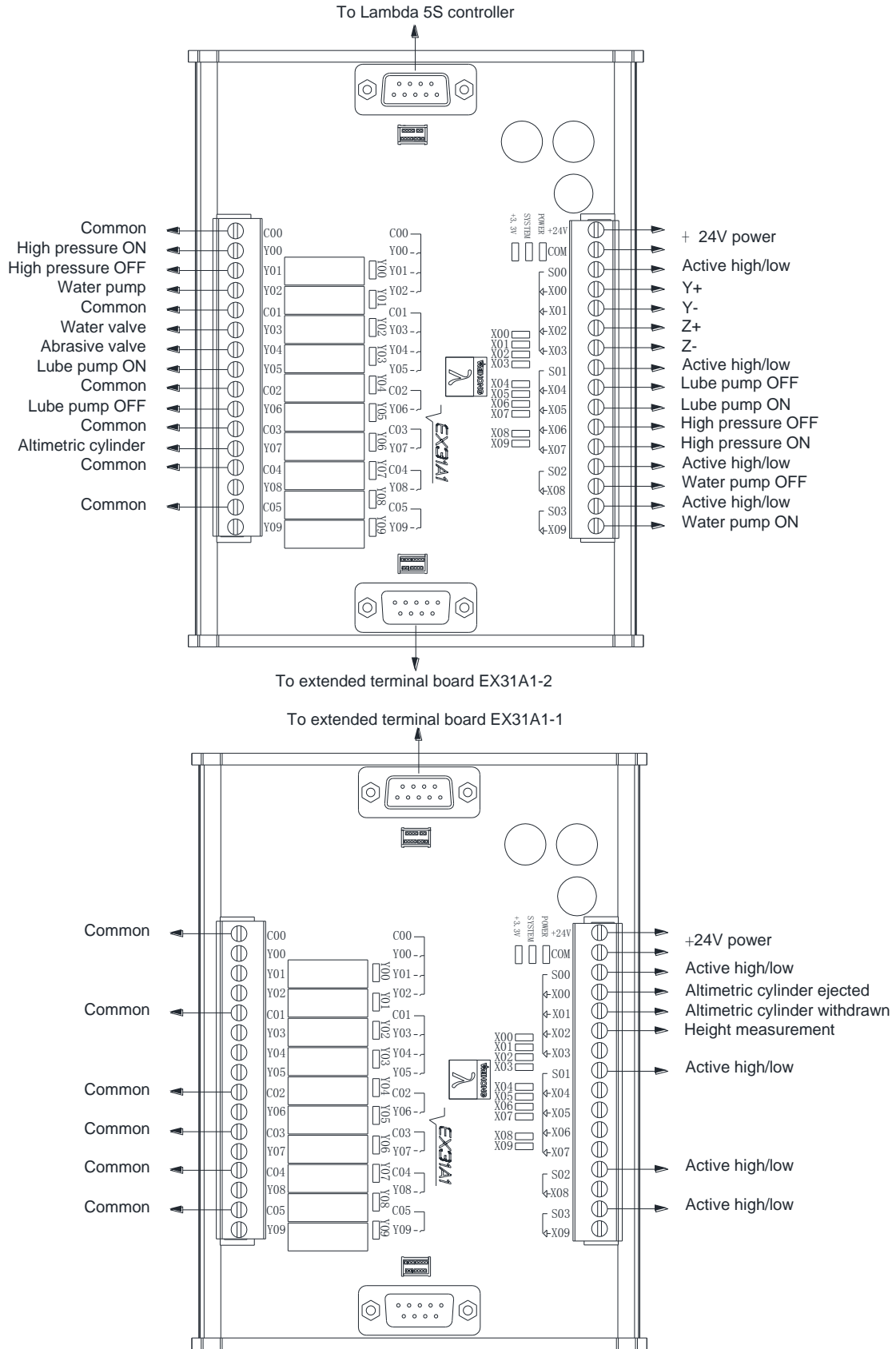

Fig. 2-24 Wiring example of EX31A1 according to XYZC configuration according to waterjet cutting software

**2.2.3.6 XY1ZCY2 Configuration in Waterjet Cutting Software**

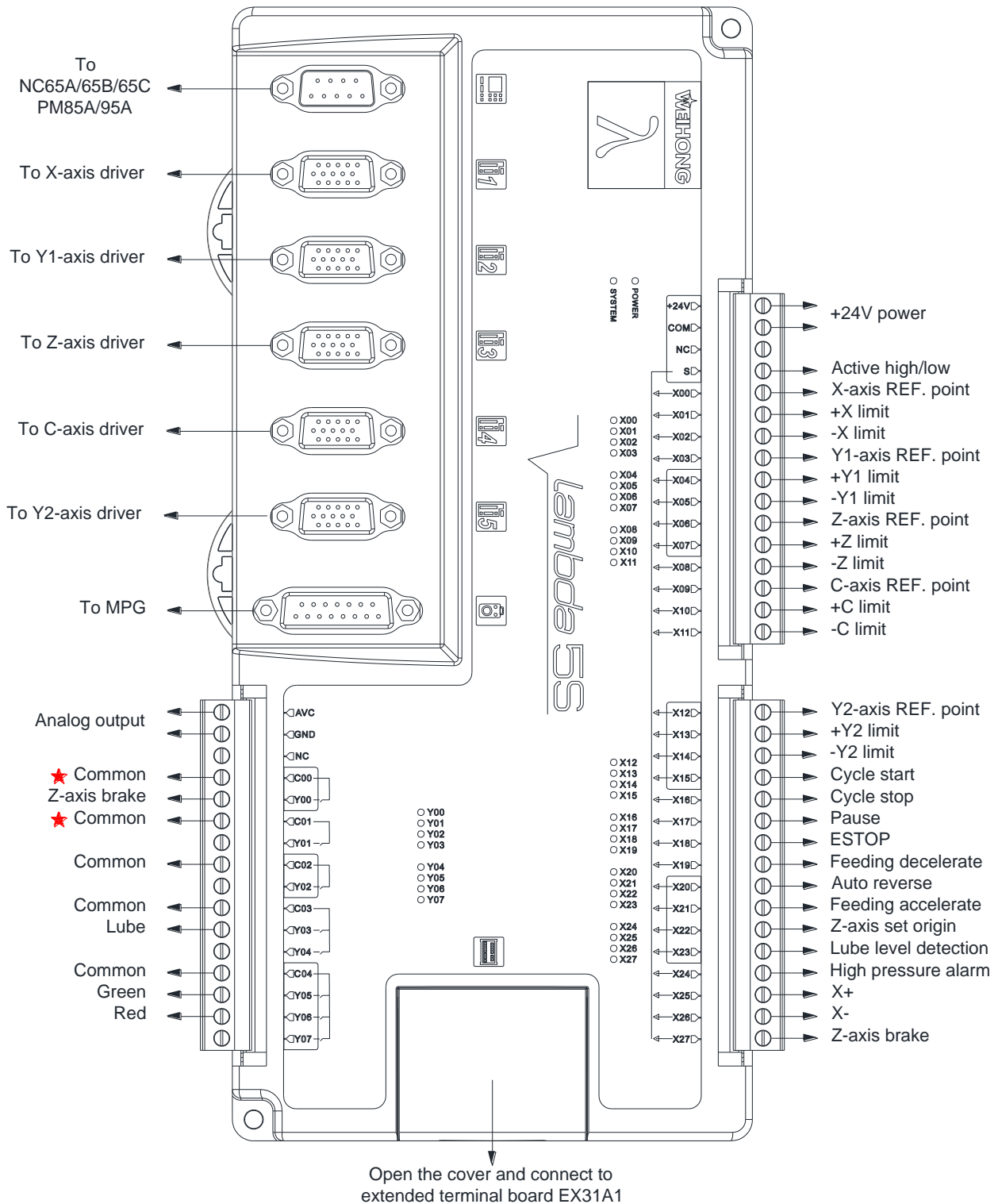

Fig. 2-25 Wiring according to XY1ZCY2 configuration according to waterjet cutting software

Two pieces of extended terminal board EX31A1 (153mm\*118mm\*56.45mm) are required in XY1ZCY2 configuration. The wiring is as shown in Fig. 2-26.

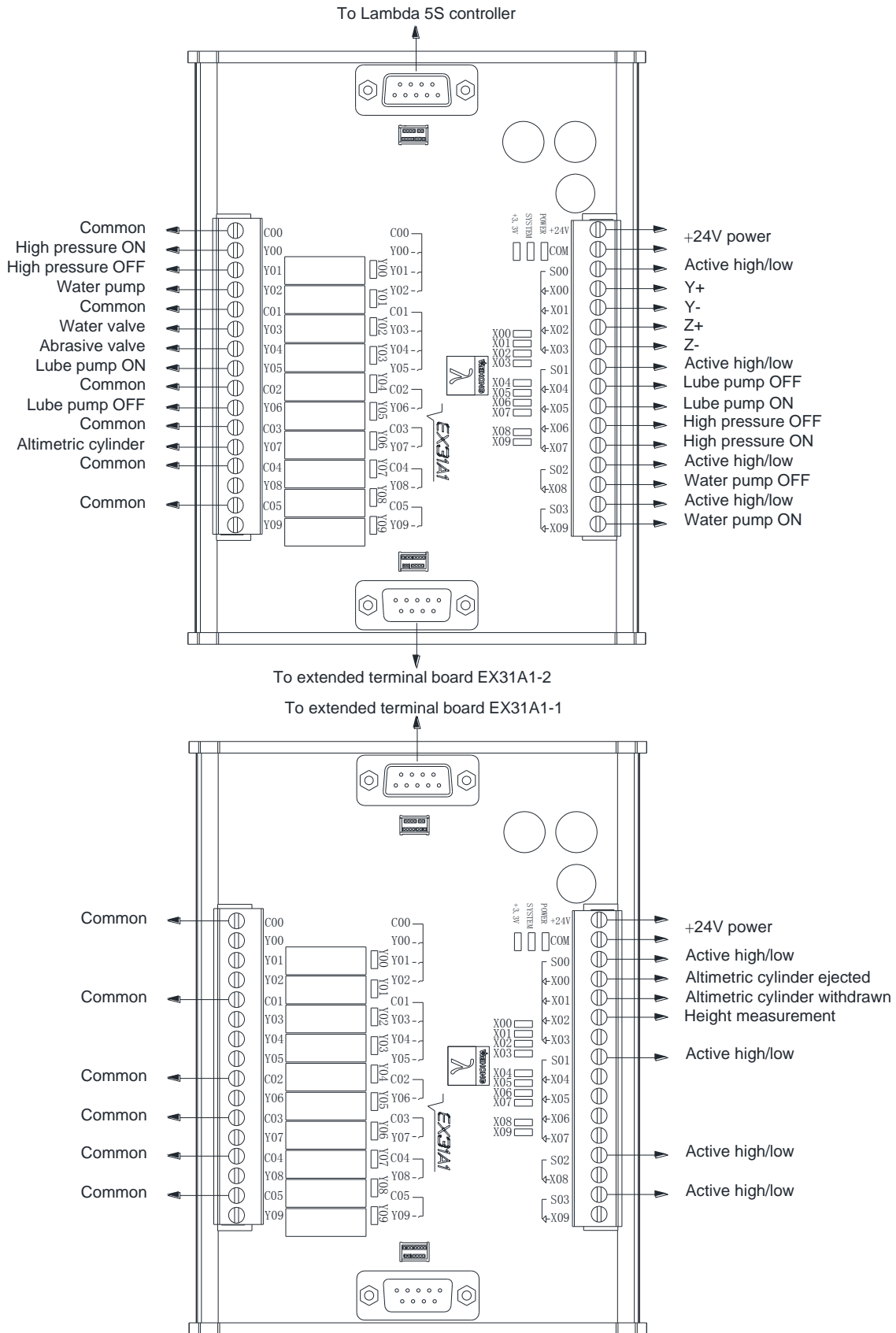

Fig. 2-26 Wiring example of EX31A1 according to XYIZCY2 configuration according to waterjet cutting software



Only one piece of EX31A1 is enough if height measurement function is not needed.

**2.2.3.7 StadA with 2Y Configuration in Waterjet Cutting Software**

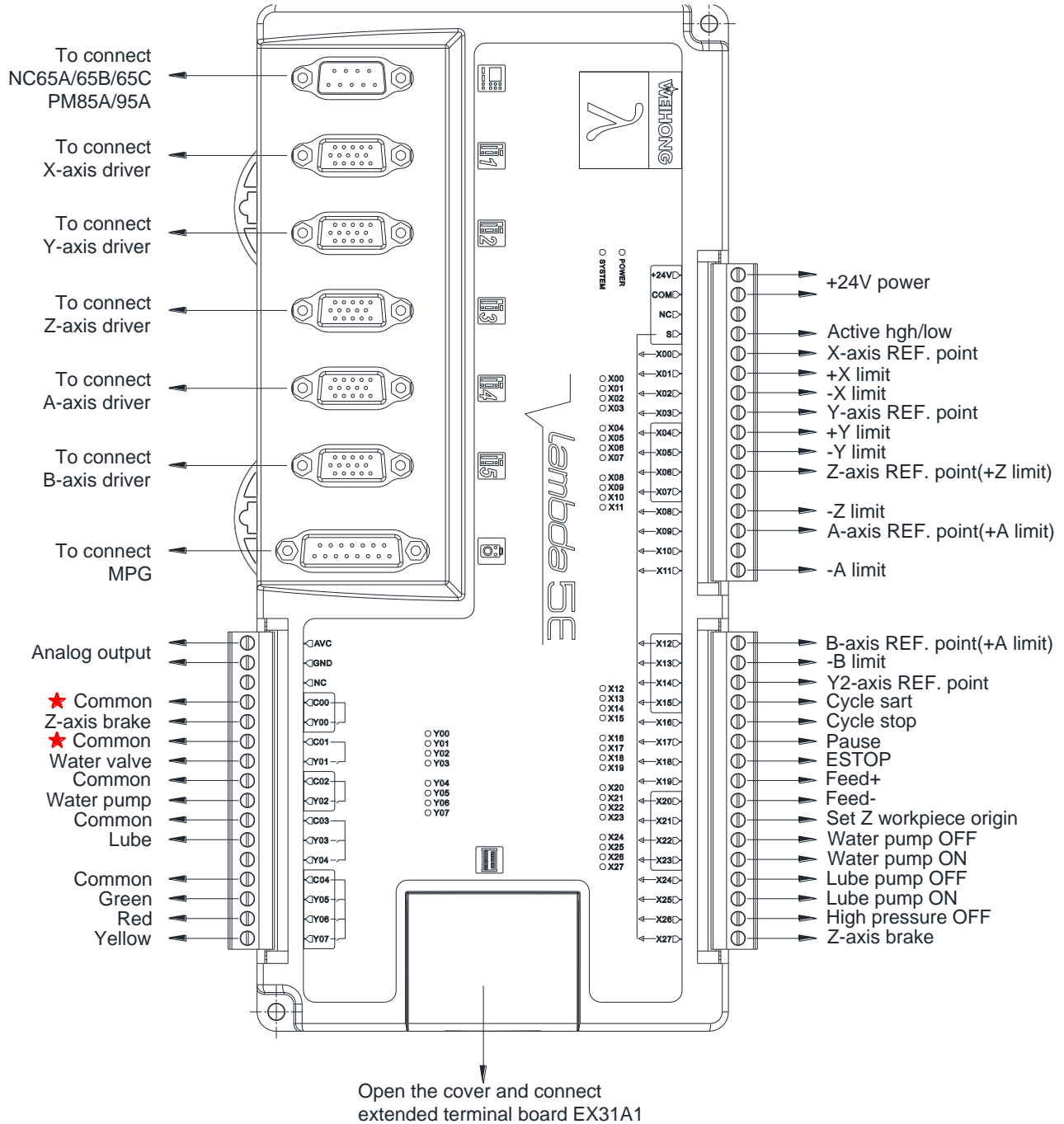

Fig. 2-27 Wiring according to StadA with 2Y configuration according to waterjet cutting software



- 1) The REF. point and positive limit of Z axis share the same port, so do the REF. point and positive limit of A axis, while the REF. point and negative limit of B axis share the same port.
- 2) The wiring according to StadA configuration is the same as that according to StadA with 2Y configuration, except that the input port X14 is reserved for use instead of being defined as the Y2-axis REF. point. The Y2 axis in dual Y configuration is controlled by pulses

Two pieces of extended terminal board EX31A1 (153mm\*118mm\*56.45mm) are required according to five-axis waterjet cutting software, with wiring as shown in

Fig. 2-28.

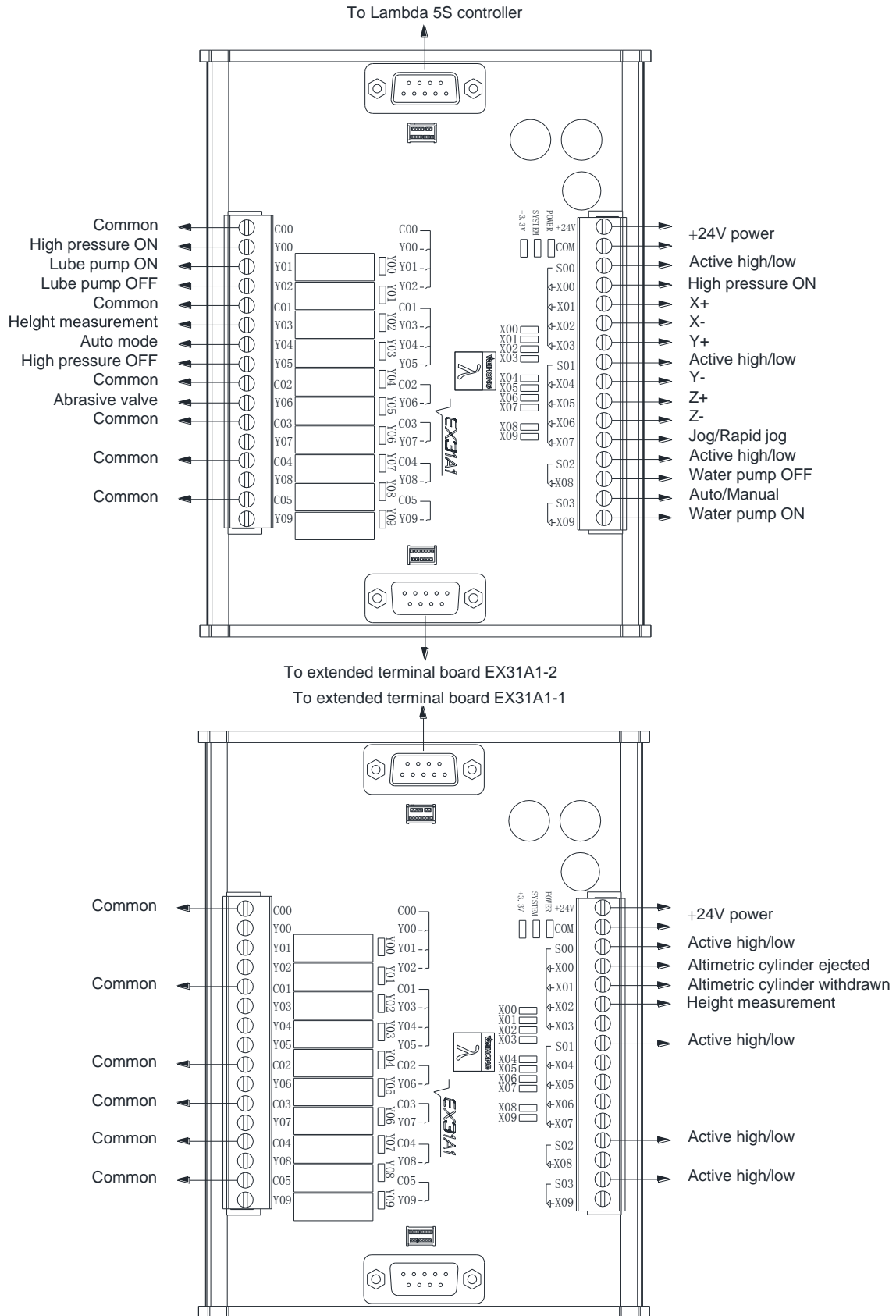

Fig. 2-28 Wiring of EX31A1 according to StadA with 2Y configuration according to waterjet cutting software



Only one piece of EX31A1 is enough if height measurement function is not needed.

In case of five-axis waterjet cutting machines of AC-type, wiring of Lambda 5S or Lambda 5E controller are the same. Below is an example of wiring of Lambda 5E controller.

### 2.2.3.8 In case of Five-axis Waterjet Cutting Machines of AC-type

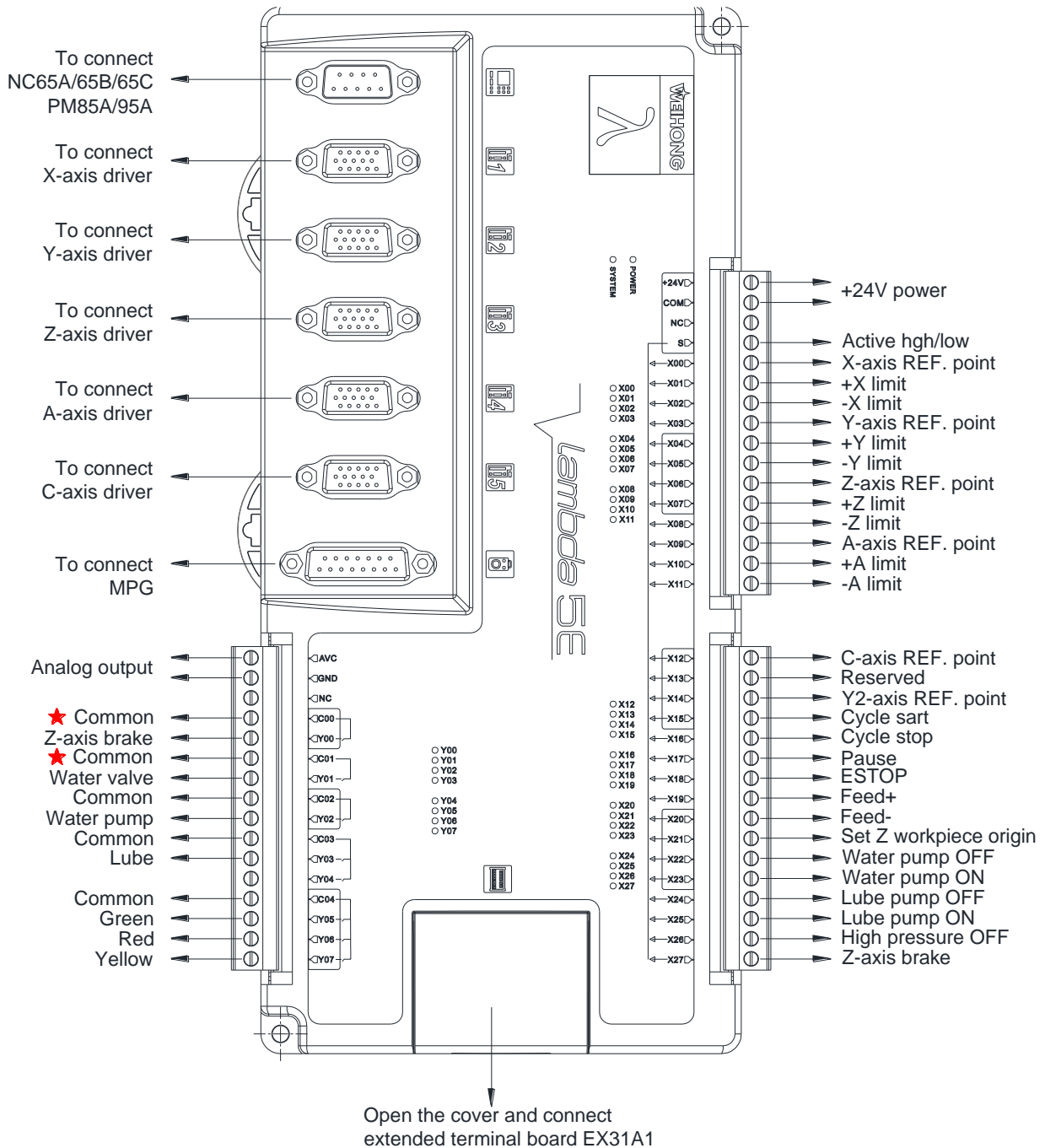

Fig. 2-29 Wiring in case of five-axis waterjet cutting machine of AC-type

Under this configuration, two pieces of extended terminal boards EX31A1 (153mm\*118mm\*56.45mm) are used. The wiring diagram is as shown below.

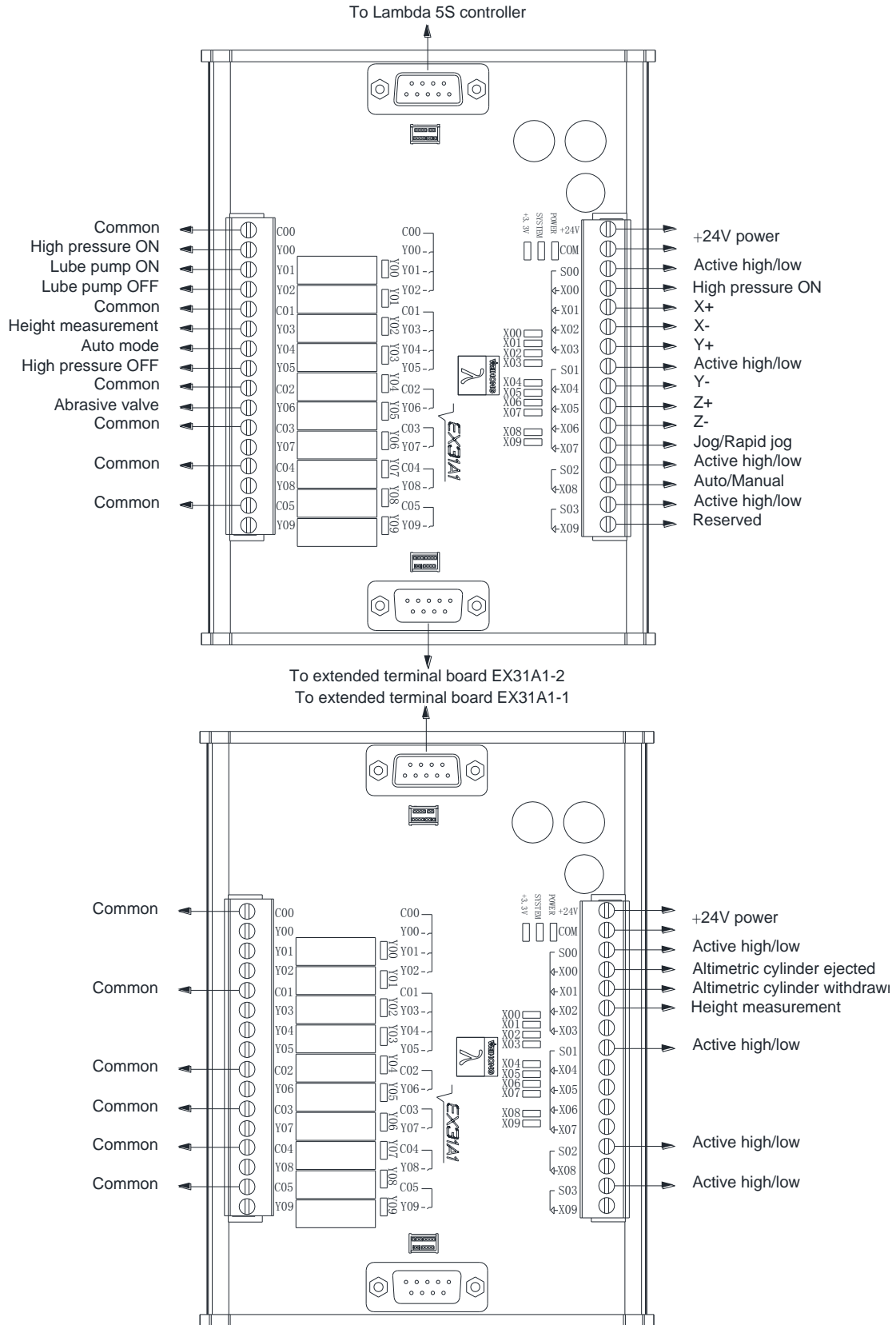

Fig. 2-30 Wiring example of extended terminal board EX31A 1in case of five –axis waterjet cutting machine of AC-type



## 2.2.4 Wiring of Three-axis Configuration in Laser Cutting

### Software

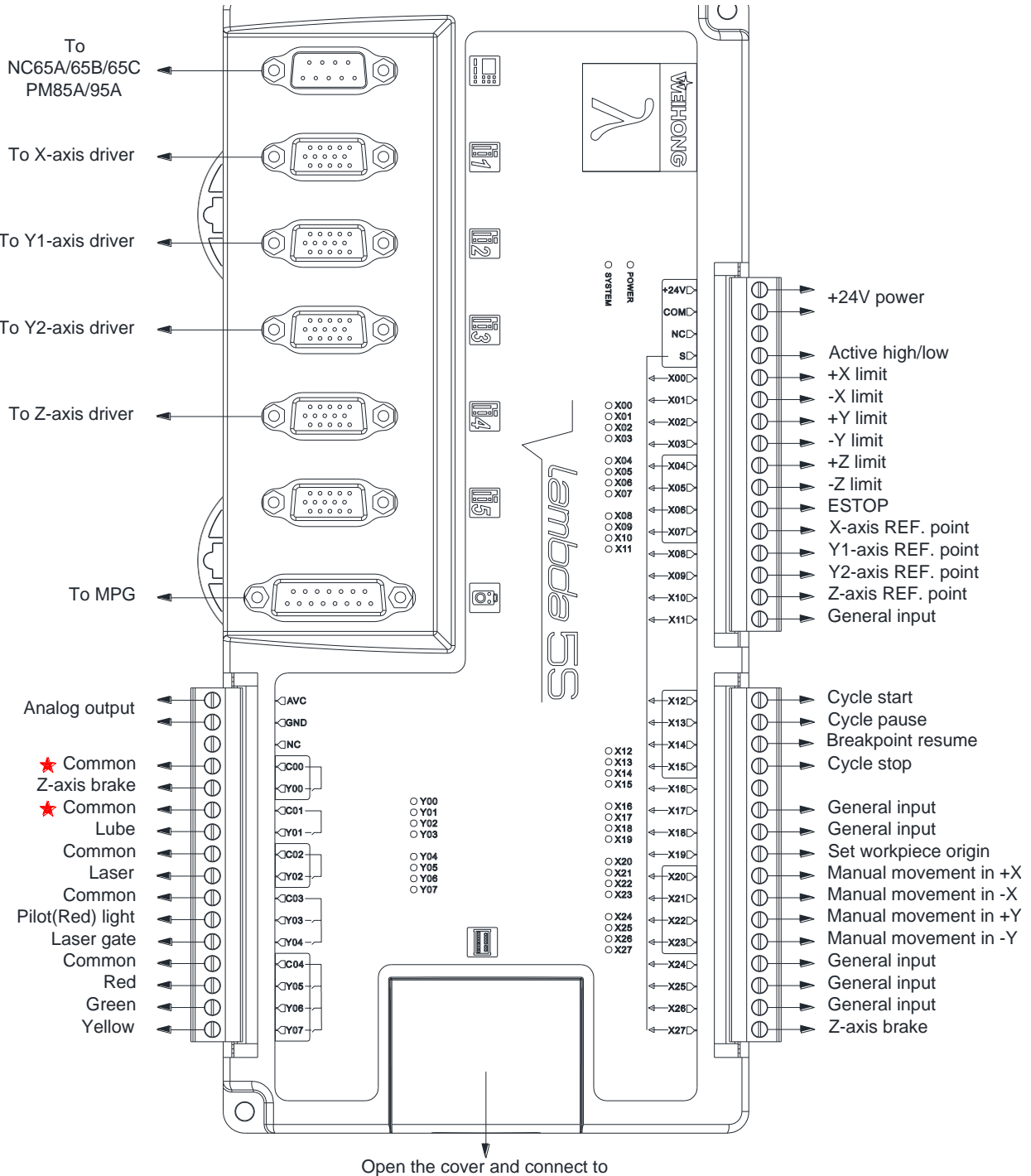

Fig. 2-31 Wiring according to three-axis dual Y configuration according to laser cutting software



The software consists of single Y configuration and dual Y configuration.

- 1) In single Y configuration, only X, Y and Z axes should be connected to the first three axes driver interfaces.
- 2) In single Y configuration, X08 is defined as Y-axis REF. point and X09 general input.

Extended terminal board EX30A5 (195mm\*118mm\*56.5mm) is required in laser cutting, with wiring diagram as shown in Fig. 2-32.

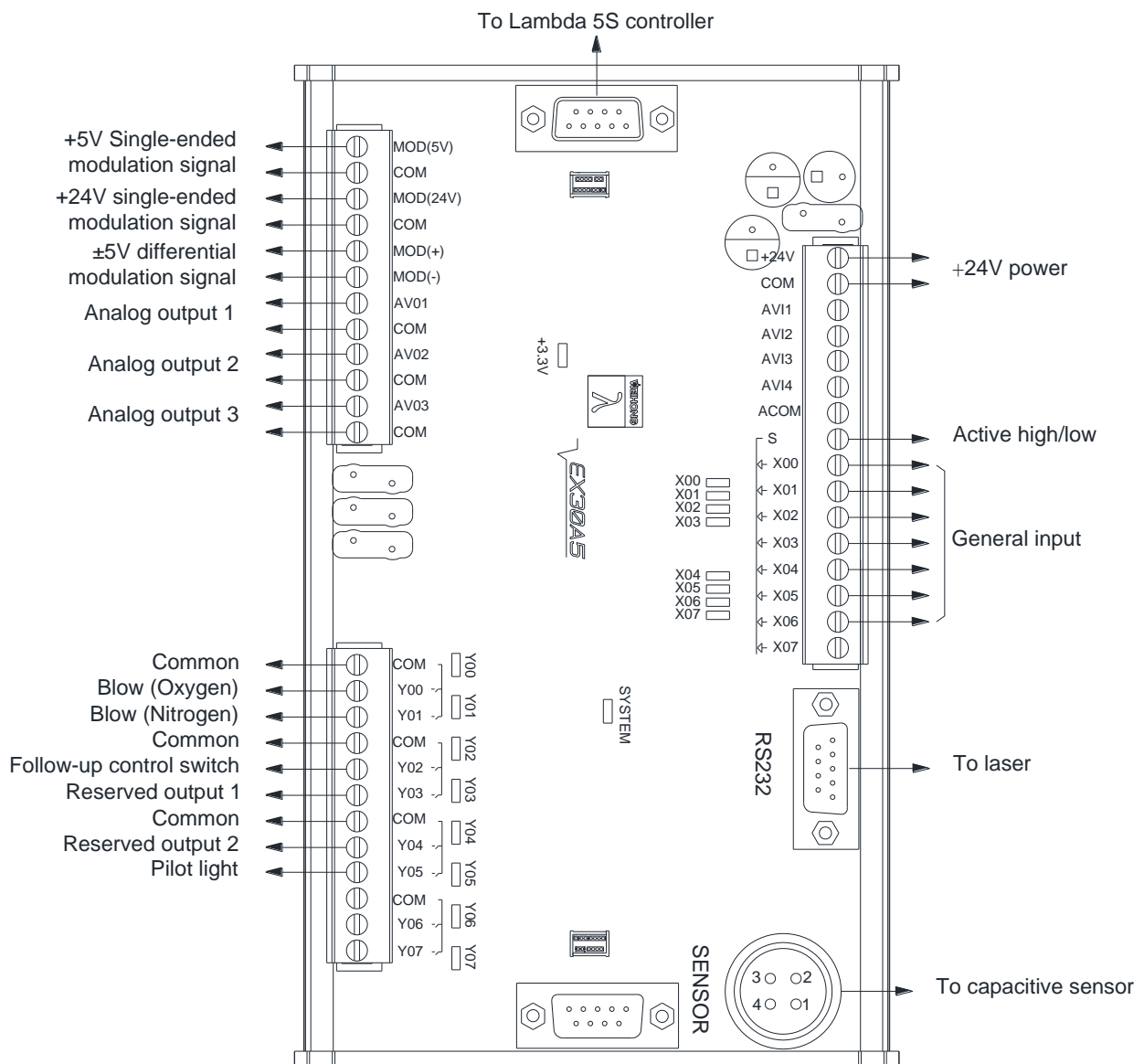

Fig. 2-32 Wiring of EX30A5 according to laser cutting software



- 1) Ex30A5 is an upgraded version of EX30A3. Its layout has changed, while the port information has not. You can still use EX30A3 in this case.
- 2) The outputs of extended terminal board EX30A5 are Darlington outputs, and their load current should be  $\leq 0.4A$ .
- 3) Outputs Y00~Y05 should be connected to relays.

## 2.2.5 Wiring in Dual Z Axes Configuration Software

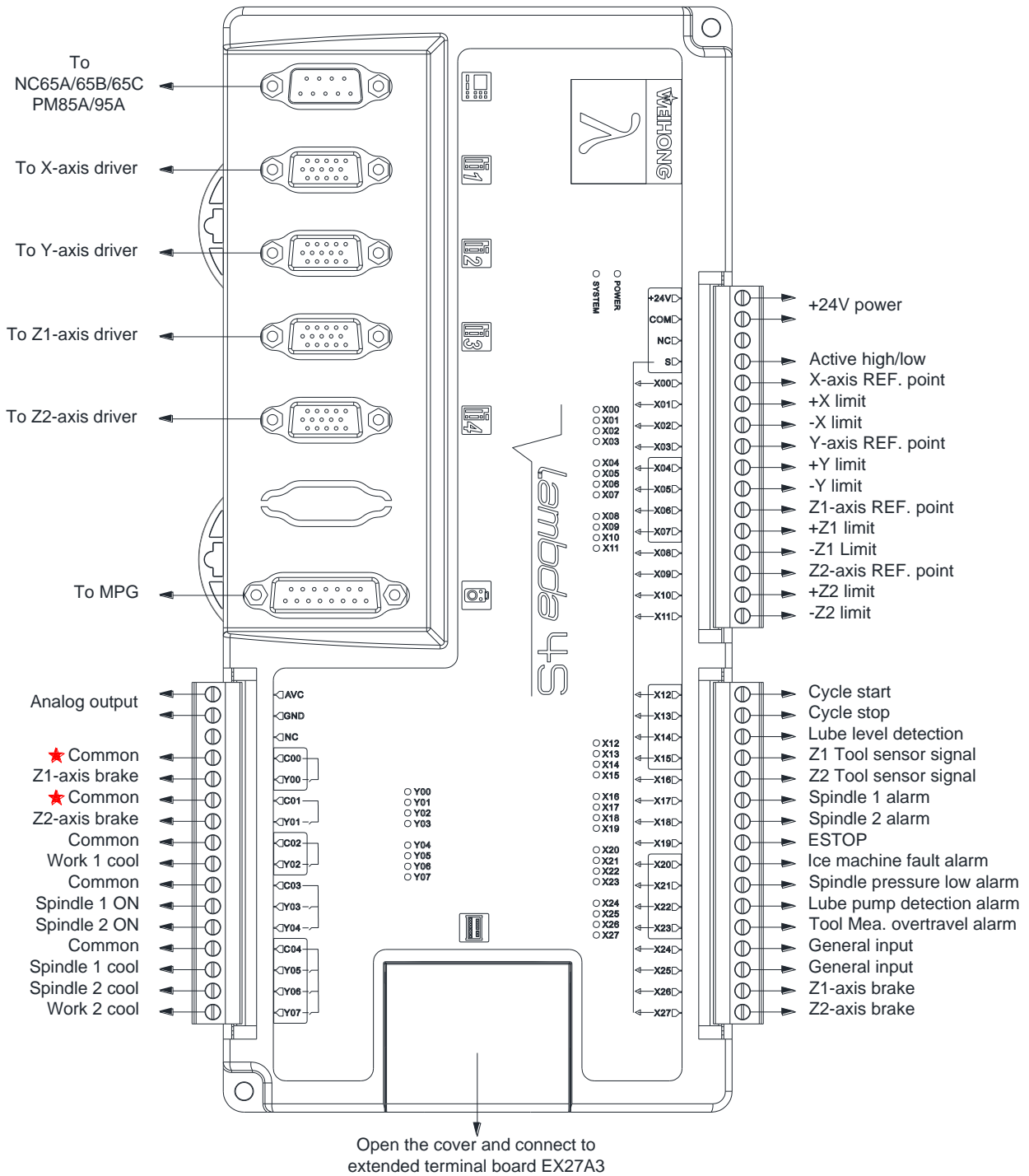

Fig. 2-33 Wiring according to dual Z axes software

Extended terminal board EX27A3 (118mm\*83mm\*56.45mm) is required in dual Z axes, with wiring diagram as shown in Fig. 2-34.

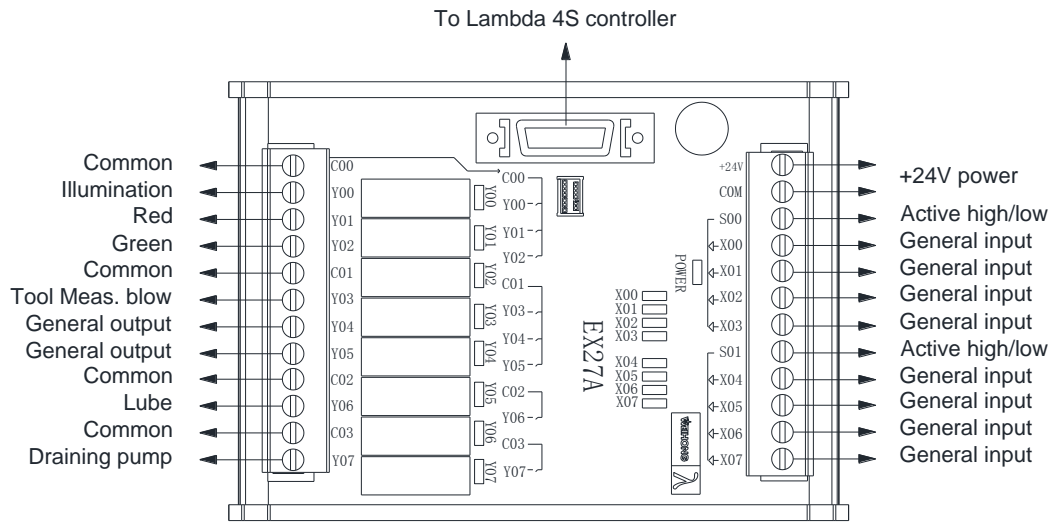

Fig. 2-34 Wiring of EX27A3 according to dual Z axes software



Dual Z axes software for general purpose includes two configurations—Z1Z2 configuration and turn configuration (alternative configuration), whose wirings are totally the same.

## 2.2.6 Wiring in Three Z Axes Configuration Software

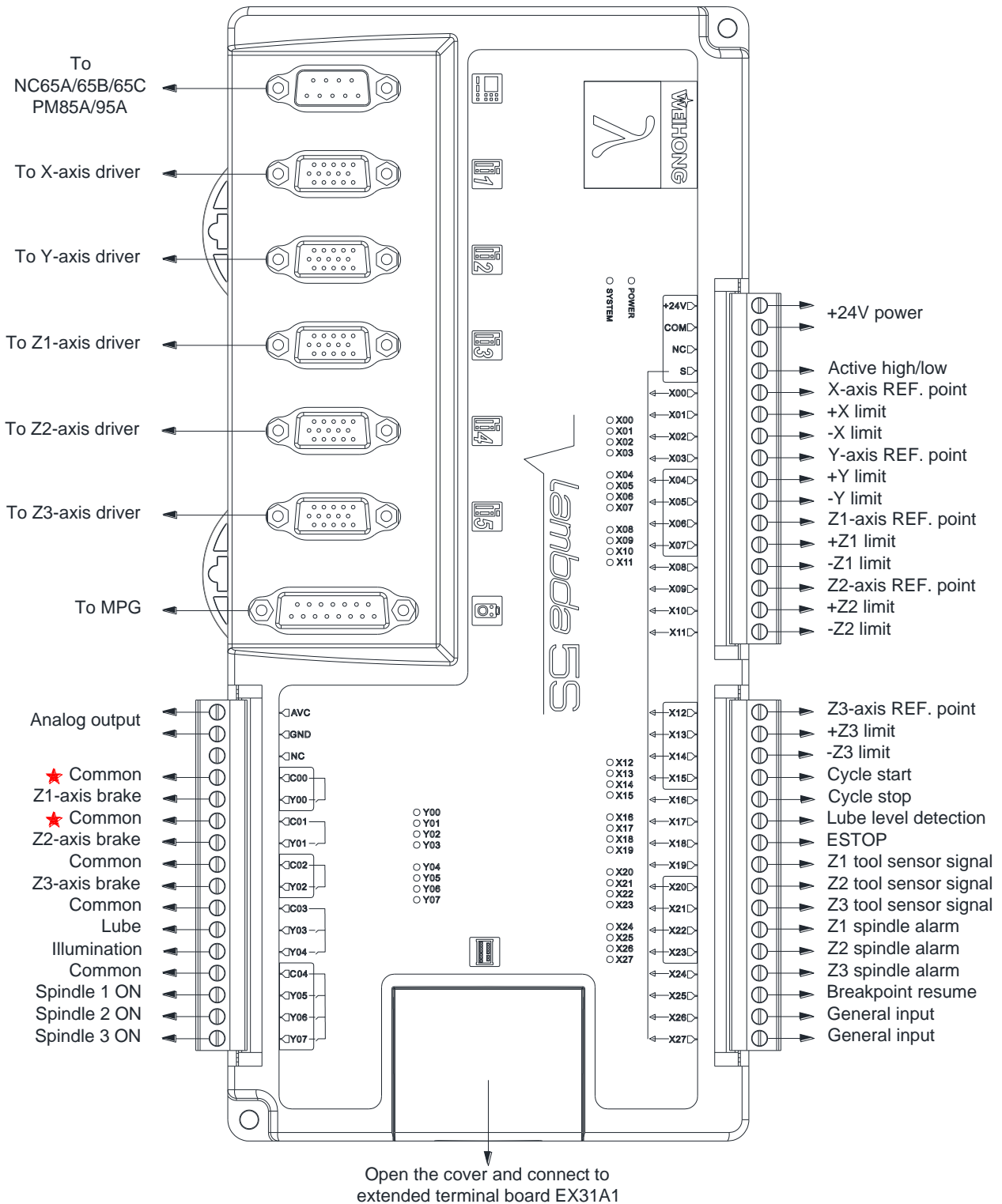

Fig. 2-35 Wiring according to three Z axes software

Extended terminal board EX31A1 (153mm\*118mm\*56.45mm) is required in three Z axes, with wiring diagram as shown in Fig. 2-36.

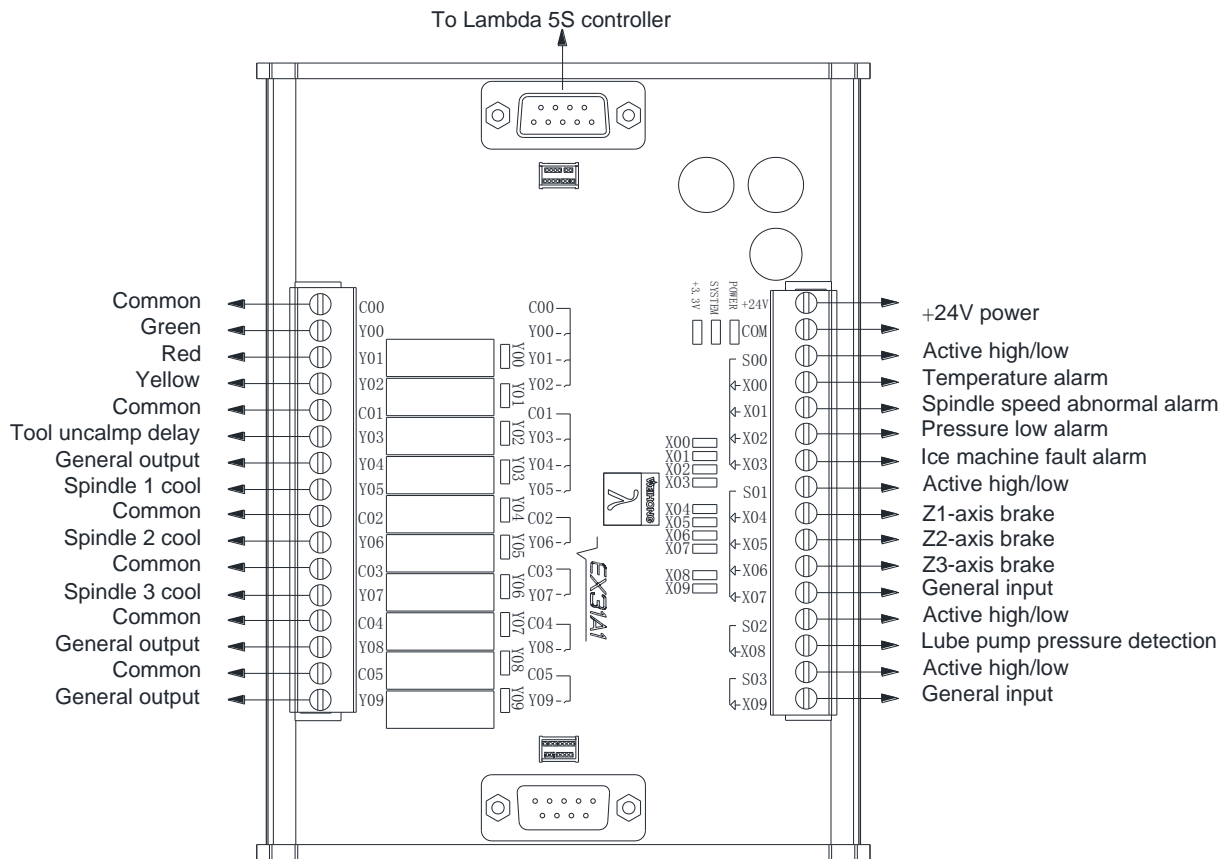

Fig. 2-36 Wiring of EX31A1 according to three Z axes software

## 2.3 Lambda 5M Controller

In bus control system, Lambda 5M controller is used. And terminal board EX31A is required to connect to Lambda 5M.

Lambda 5M works normally under voltage from 17V~30V. Its rated voltage is 24V. When the voltage difference between power and common port S is greater than 8V, the input ports are enabled. Lambda 5M and terminal board EX31A support switch between high voltage and low voltage. When S is connected to COM, inputs are active high; when connected to +24V, active low.

### 2.3.1 Waterjet Cutting

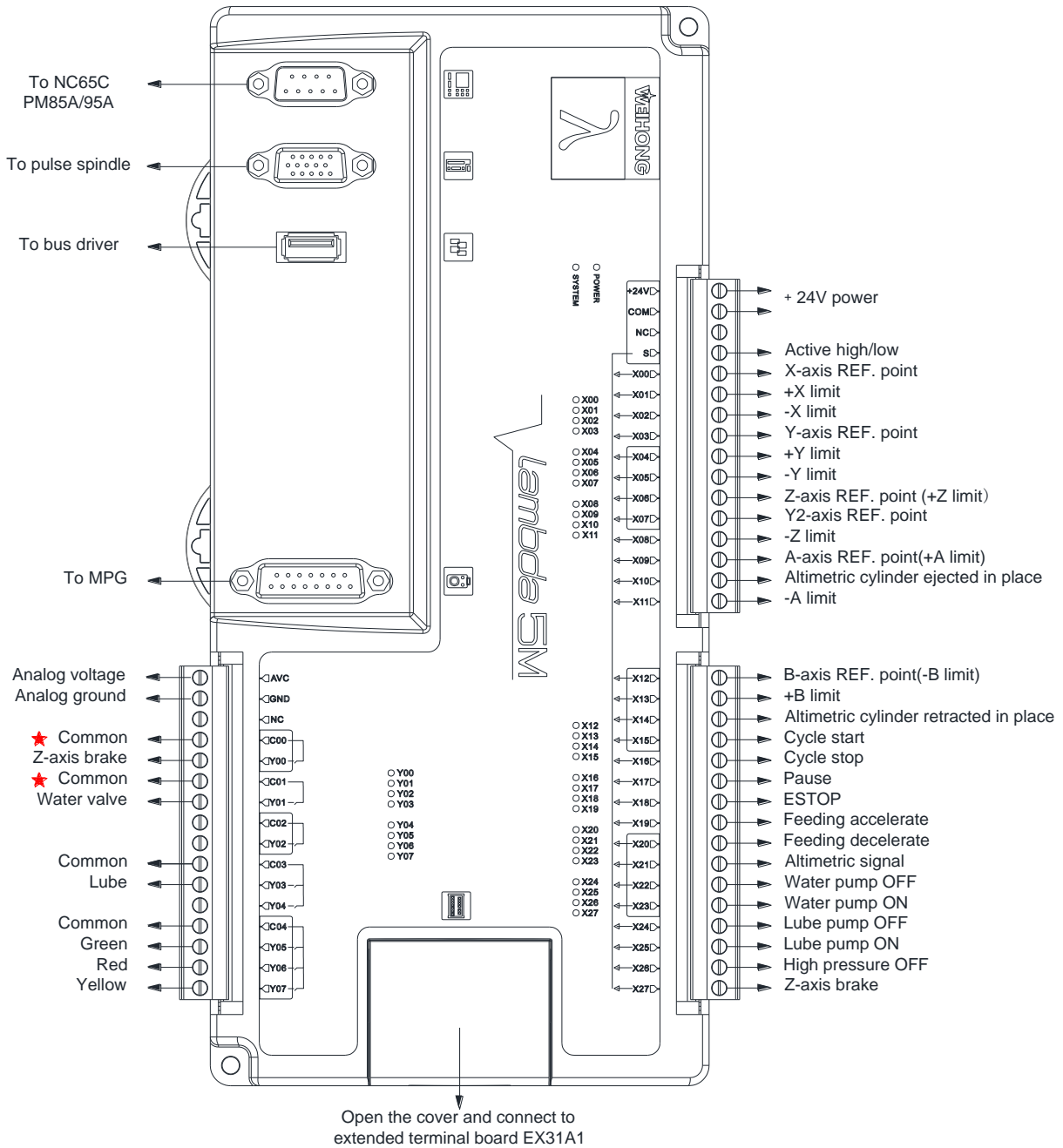

Fig. 2-37 Wiring of Lambda 5M in waterjet cutting five-axis AB structure



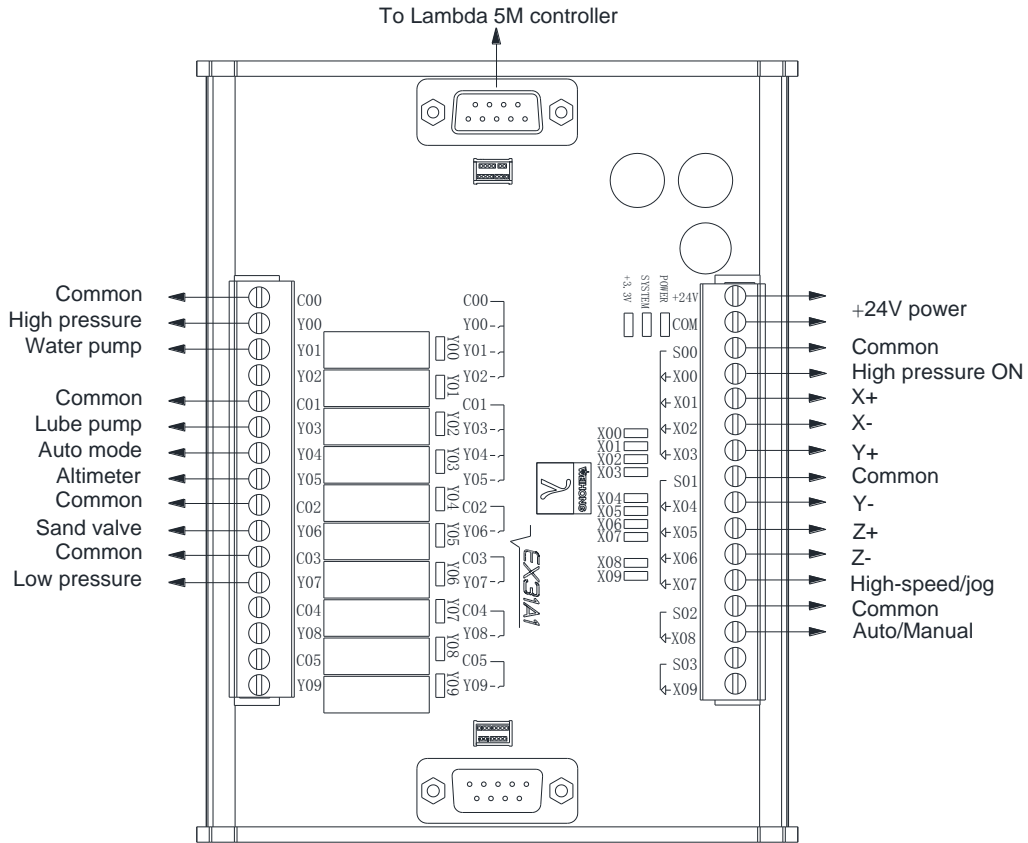

Fig. 2-38 Wiring of EX31A1 in waterjet cutting five-axis AB structure

### 2.3.2 NK280B

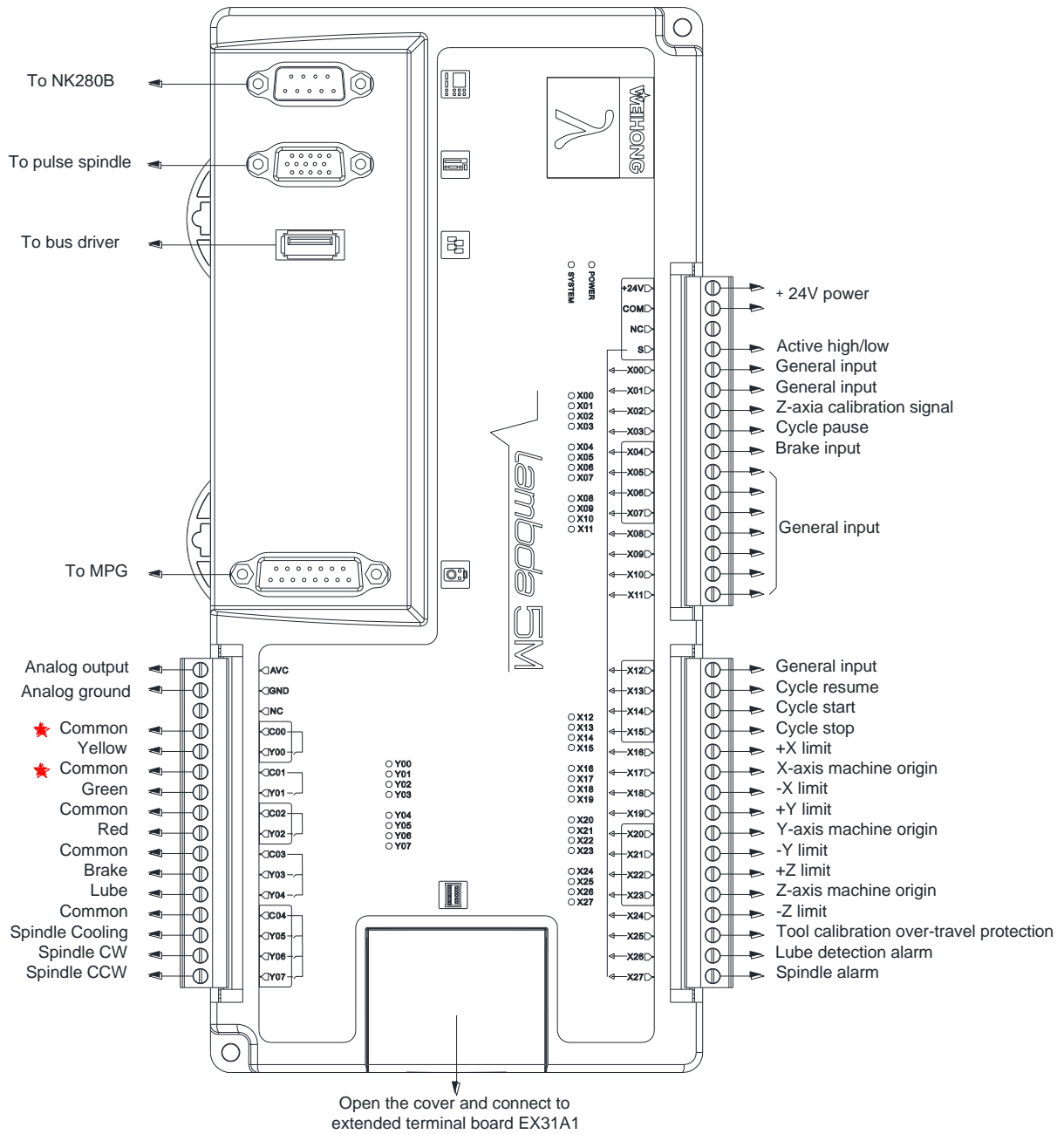

Fig. 2-39 Wiring of Lambda 5M in NK280B integrated CNC system

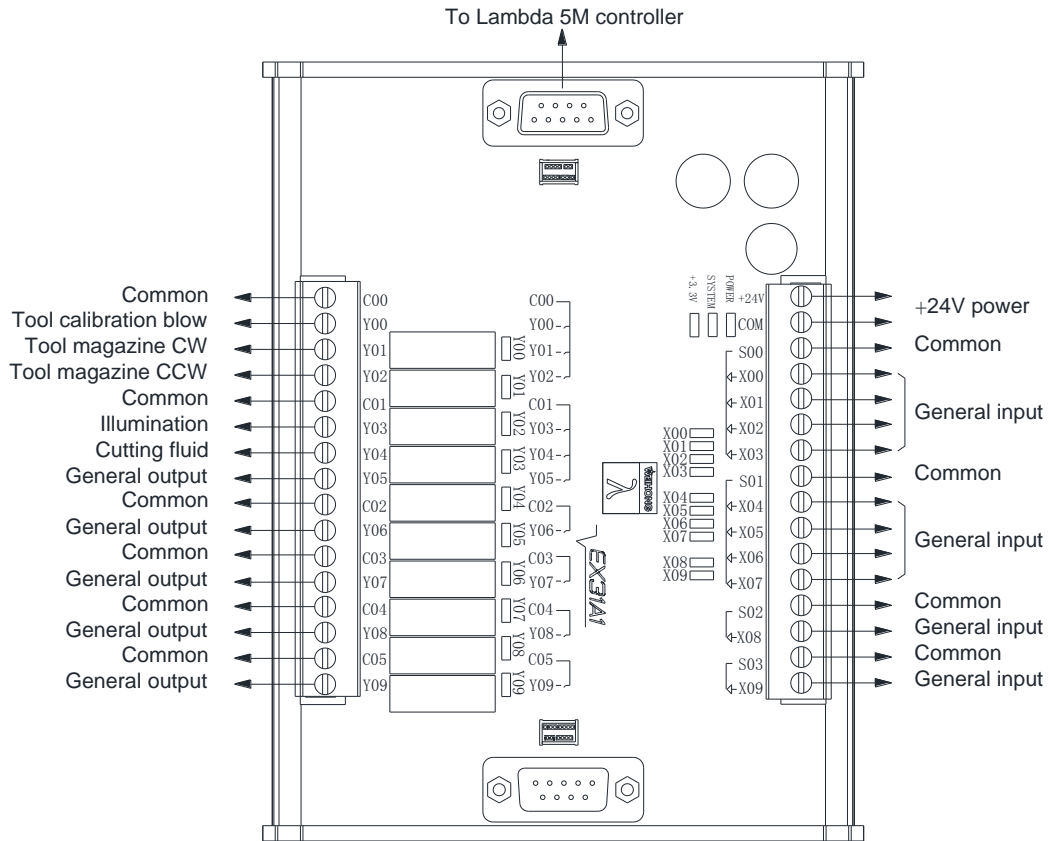

Fig. 2-40 Wiring of EX31A1 in NK280B integrated CNC system

## 2.3.3 NK300CX

### 2.3.3.1 Integrated software

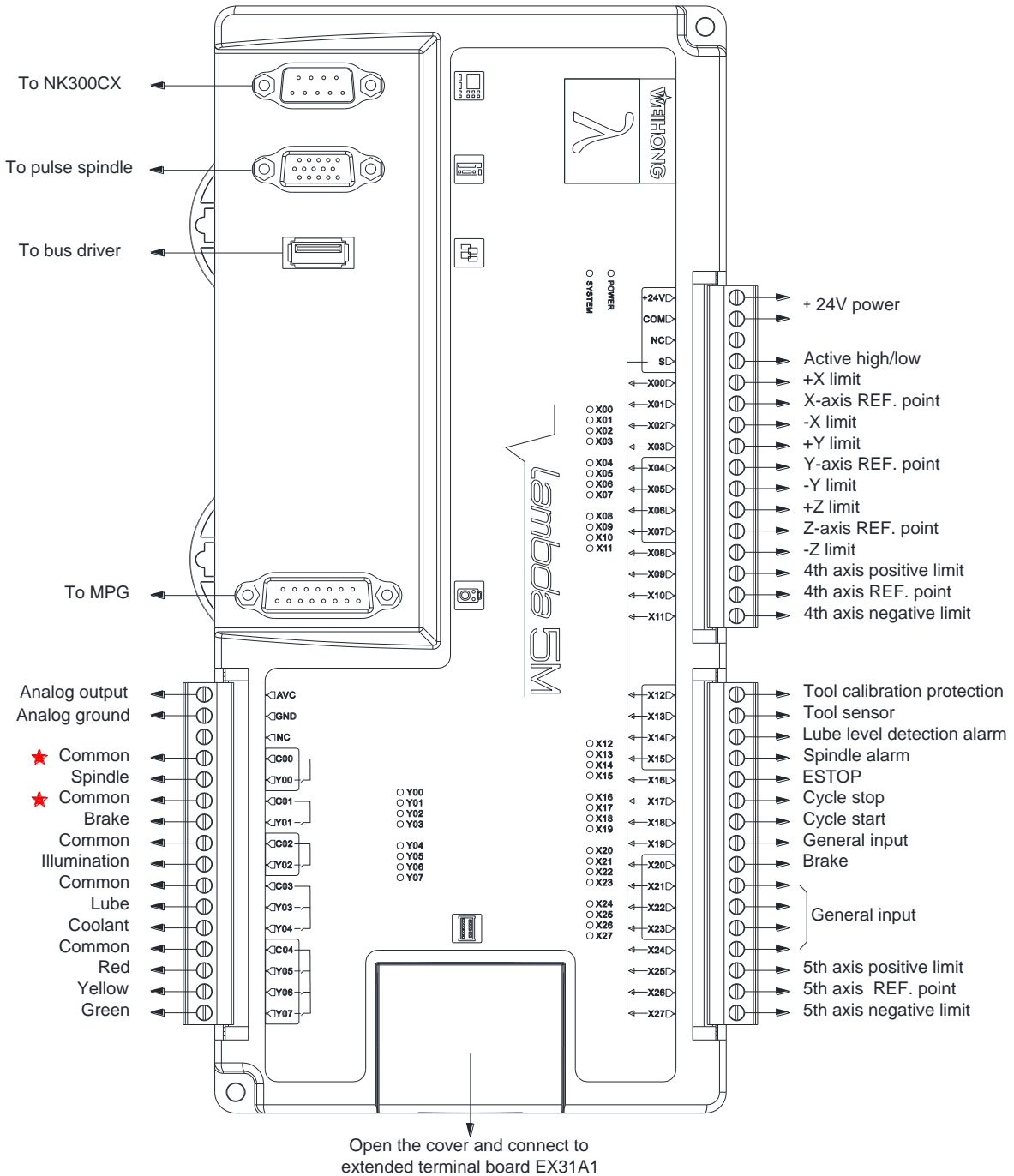

Fig. 2-41 Wiring of Lambda 5M in NK300CX integrated software

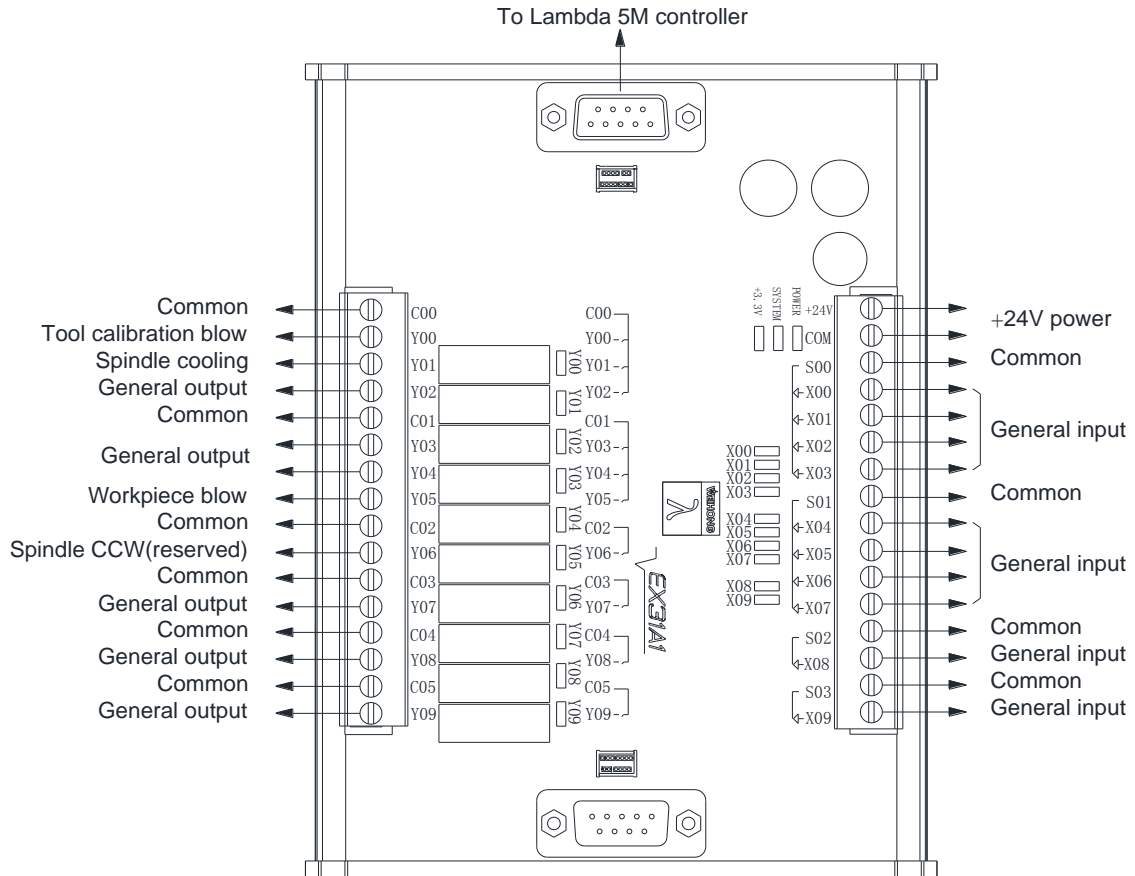

Fig. 2-42 Wiring of EX31A1 in NK300CX software (integrated)

**2.3.3.2 Union configuration in multi Z software**

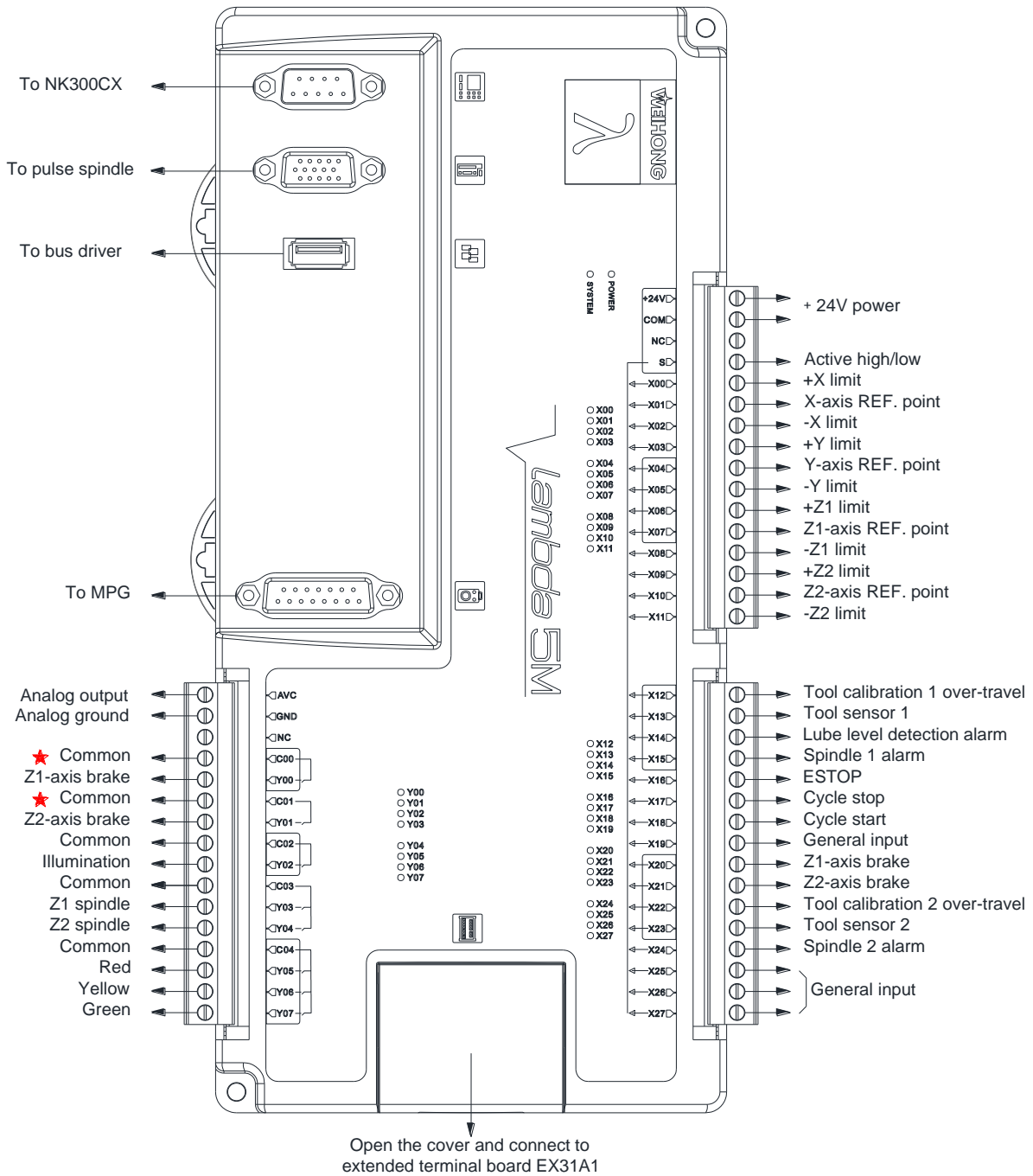

Fig. 2-43 Wiring of Lambda 5M in union configuration in NK300CX software (multi Z)

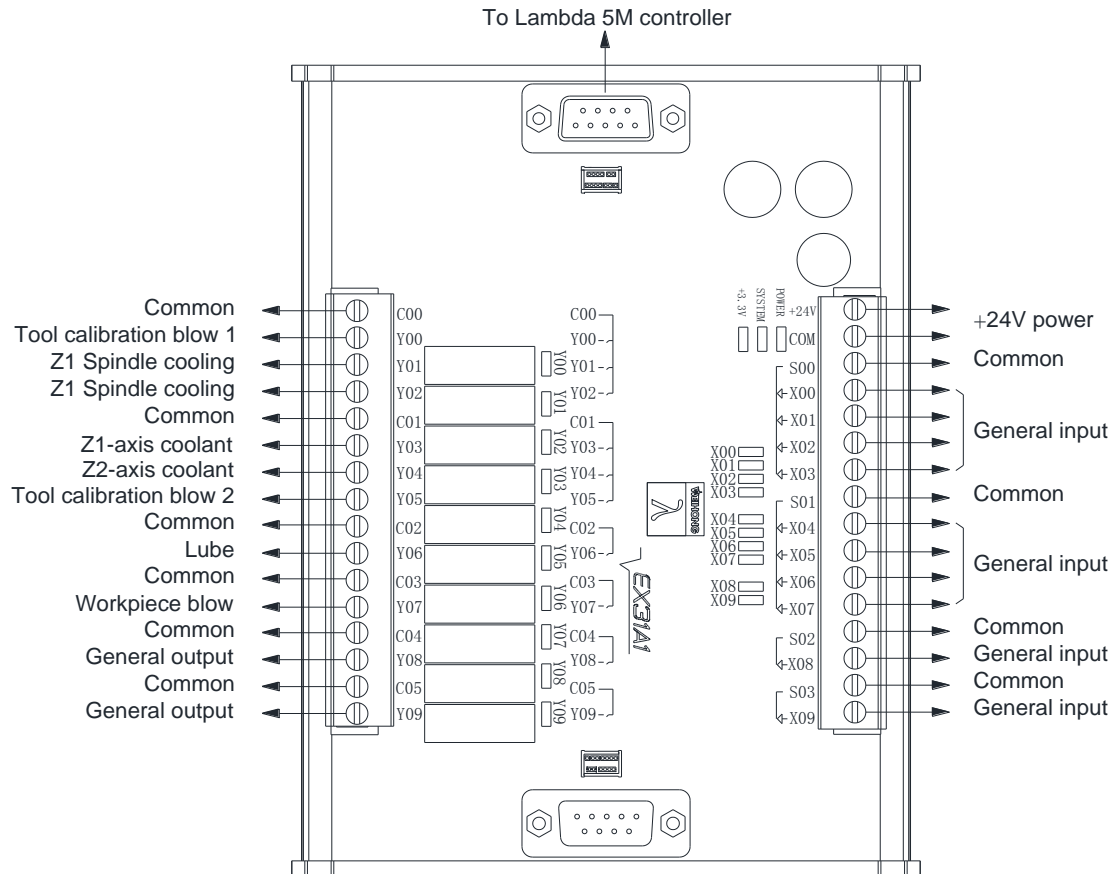

Fig. 2-44 Wiring of EX31A1 in union configuration of NK300CX software (multi Z)

**2.3.3.3 Turn configuration in multi Z software**

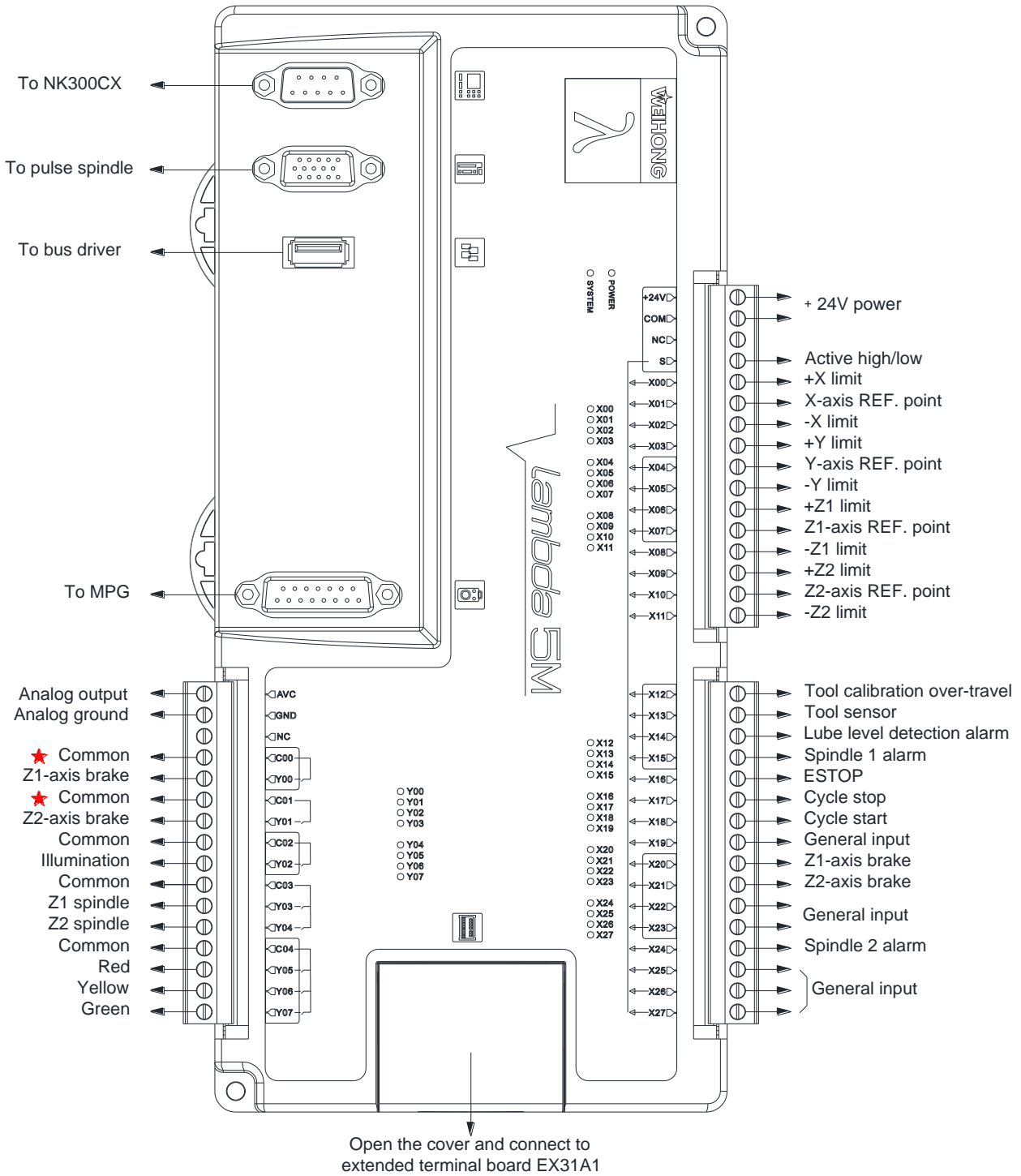

Fig. 2-45 Wiring of Lambda 5M in turn configuration of NK300CX software (multi Z)



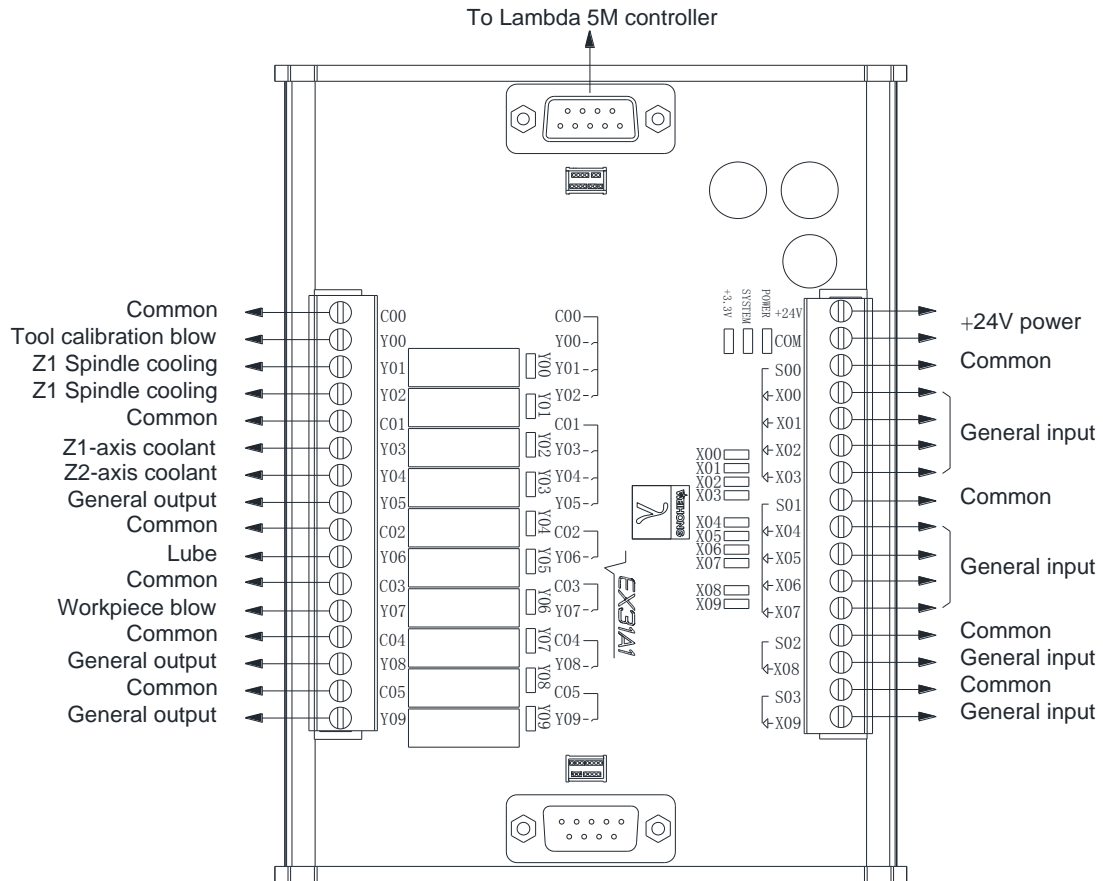

Fig. 2-46 Wiring of EX31A1 in turn configuration of NK300CX software (multi Z)

**2.3.3.4 Dual Y union configuration in multi Z software**

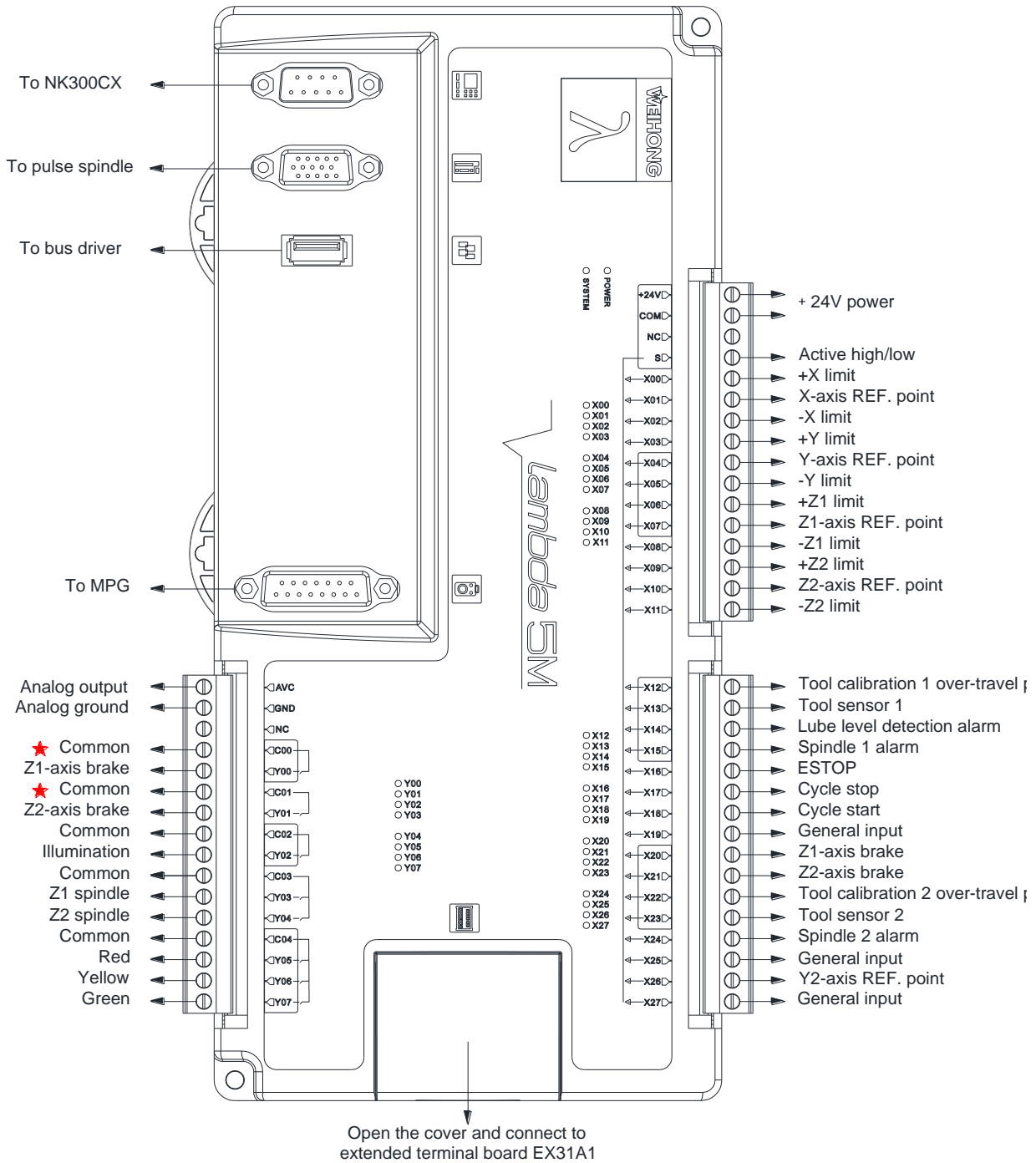

Fig. 2-47 Wiring of Lambda 5M in dual Y union configuration of NK300CX software (multi Z)

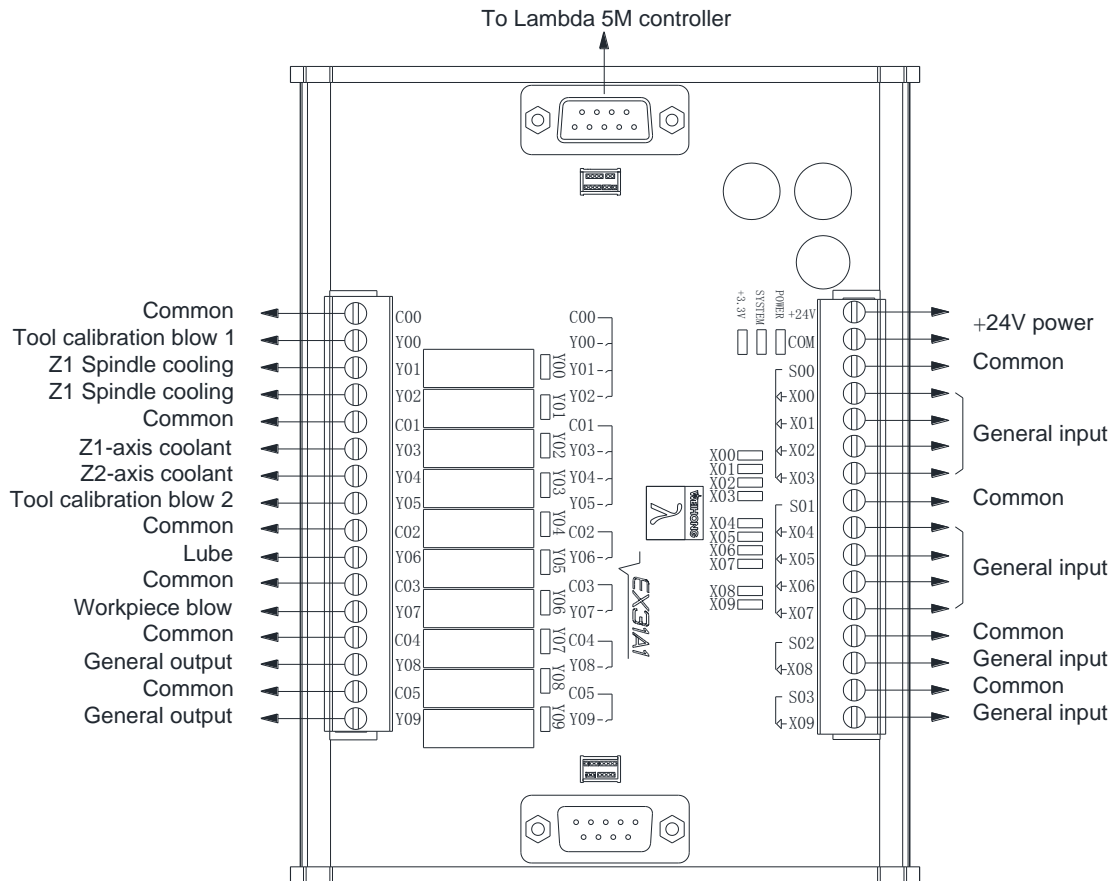

Fig. 2-48 Wiring of EX31A1 in dual Y union configuration of NK300CX software (multi Z)

### 2.3.4 NK500

The wiring of Lambda 5M in NK500 integrated software is the same as that in NK300CX integrated software. Please refer to 2.3.3.1. You only need to change “To NK300CX” into “To NK500” based on the wiring in Fig. 2-41.

### 2.3.5 NcStudio V10 Three-axis Dual Z axes

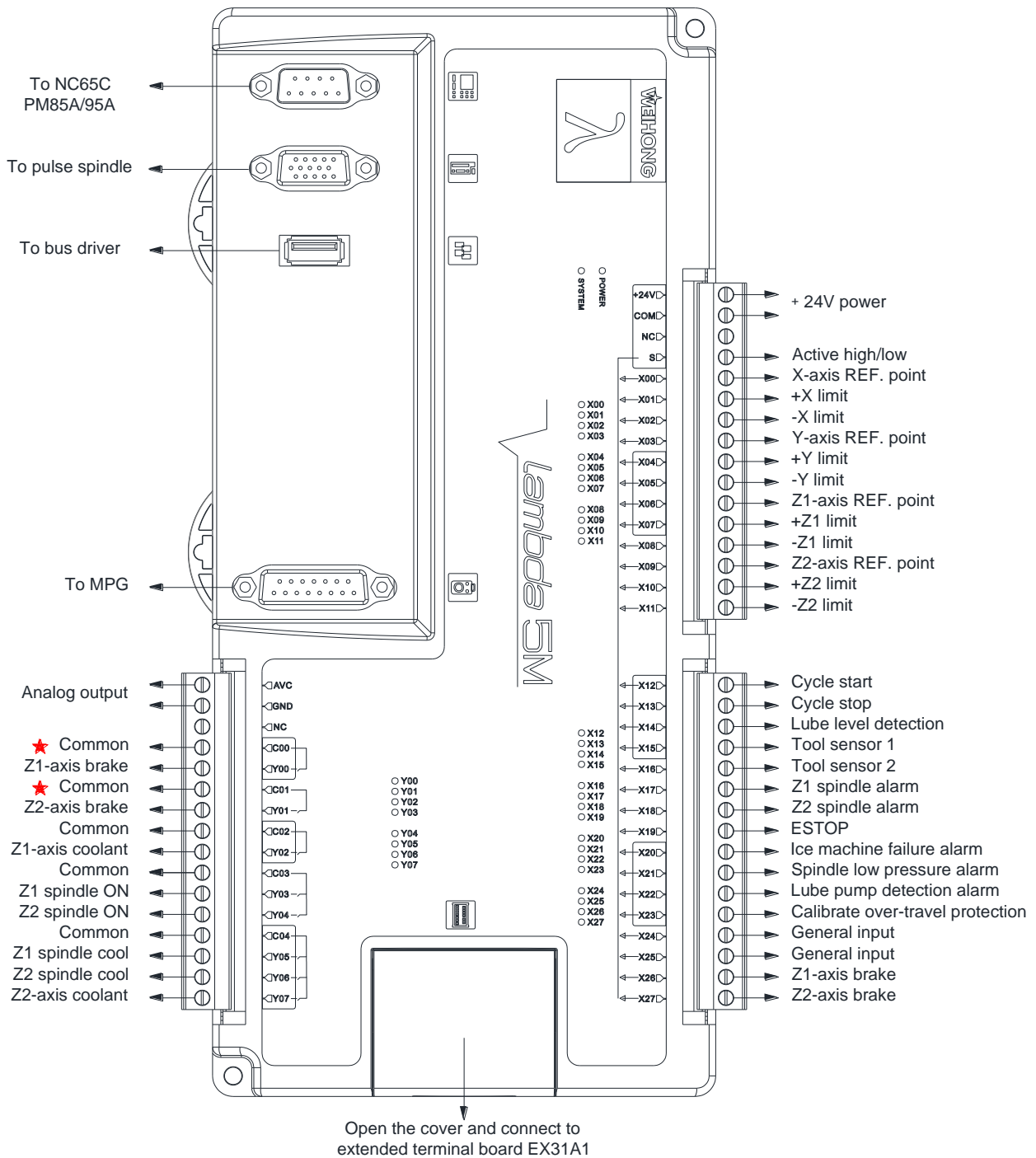

Fig. 2-49 Wiring of Lambda 5M in three-axis dual Z axes software

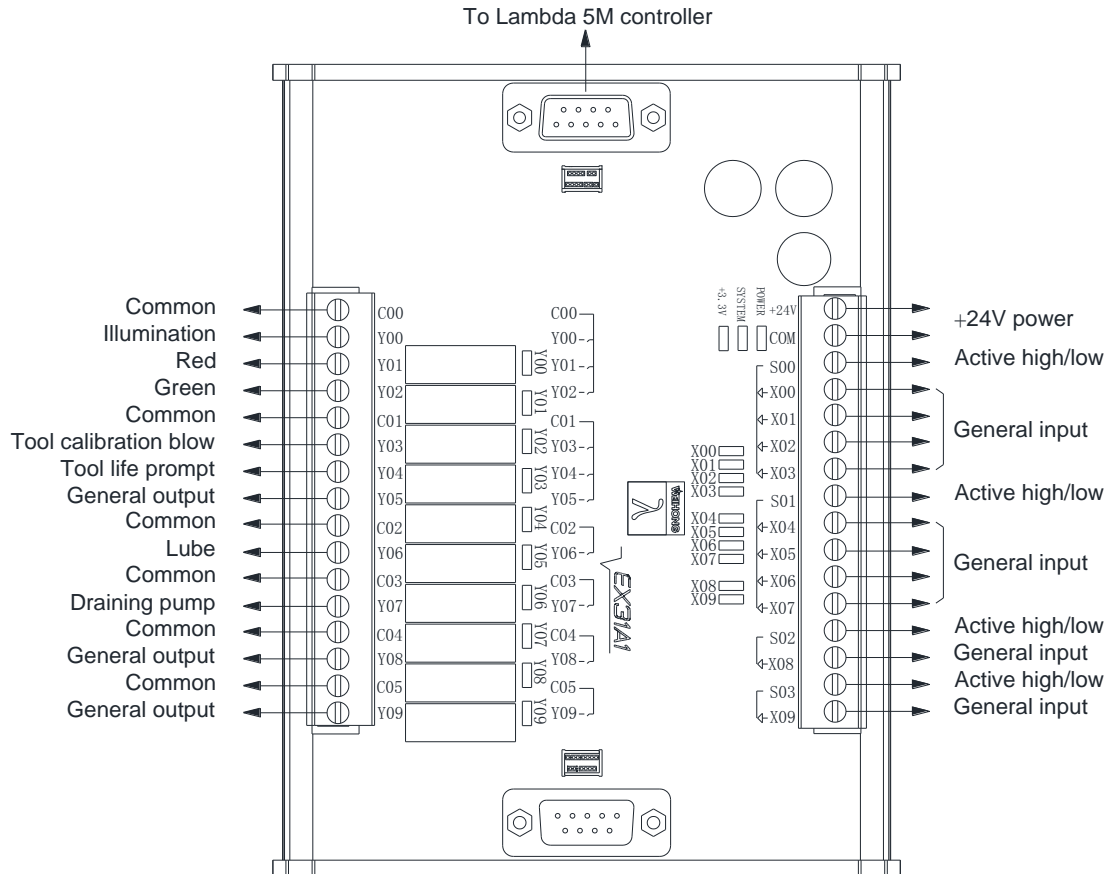

Fig. 2-50 Wiring of EX31A1 according to three-axis dual Z NcStudio V10 software



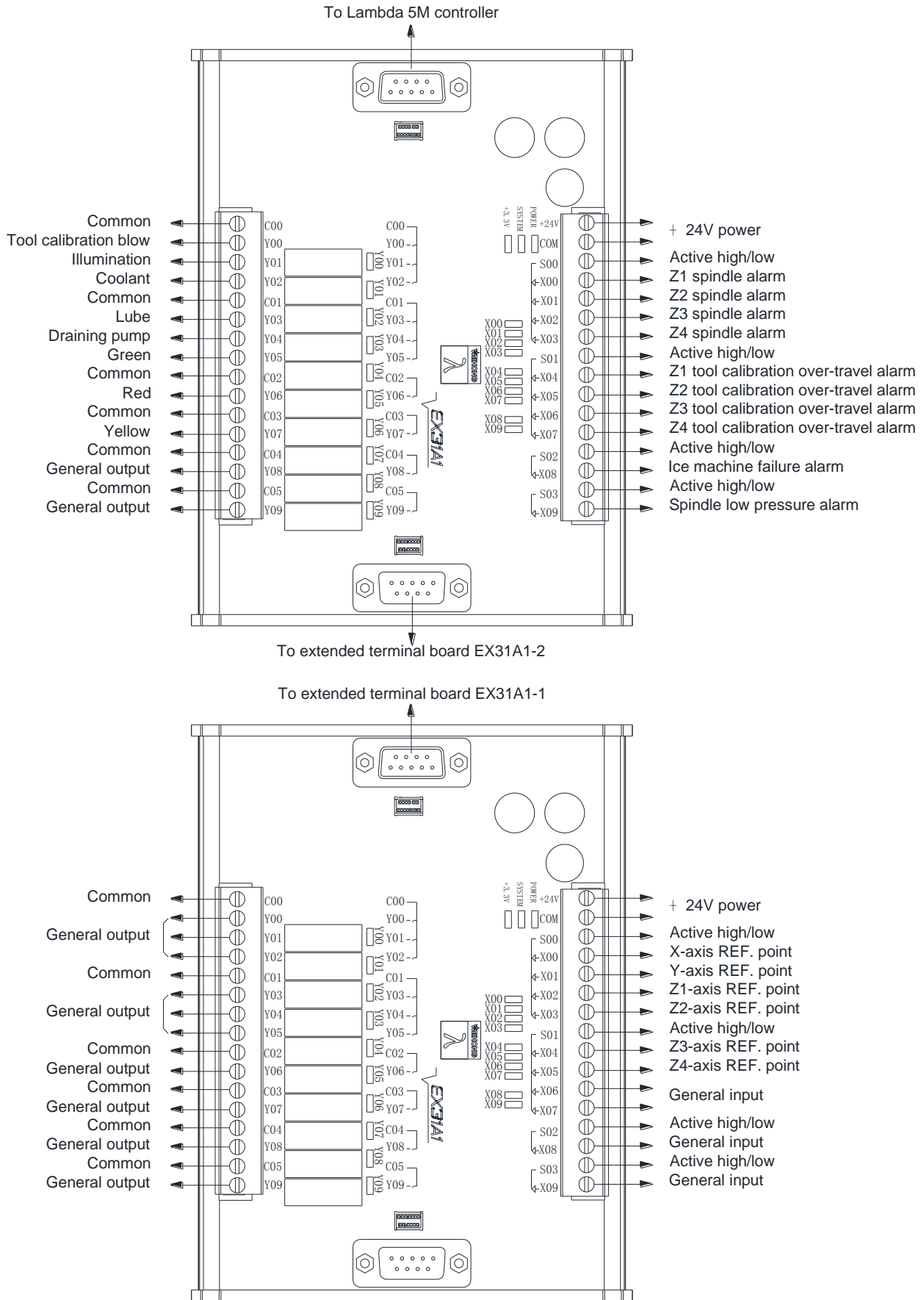

Fig. 2-52 Wiring of EX31A1 in three-axis Quadruple Z NcStudio V10 software

## 2.4 Driver Interface

### 2.4.1 Lambda 3S/3L Controller

Lambda 3S/3L controller provides 3 pulse feed driver interfaces for X/Y/Z axis. The 3 interfaces are 15-pin D-type sockets, and the pins definition is as shown in Fig. 2-53.

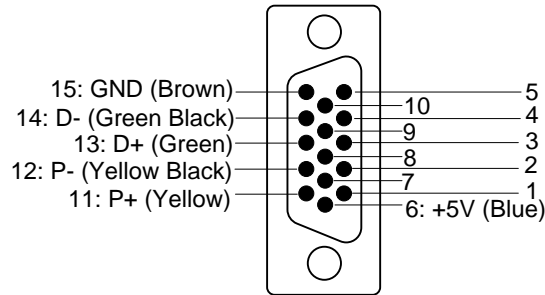

Fig. 2-53 Definition of driver interface

Only 6 of the pins should be wired when connected with a stepping driver, and the 6 wires at one end of DB15 provided by WEIHONG are distinguished by colors. You just need to connect the wires according to the colors shown in the above picture.

+5V, GND: supplying 5VDC power to a stepping driver;

P+, P-: pulse (PULS), differential output signals;

D+, D-: direction (DIR), differential output signals.

### 2.4.2 Lambda 4S/5S/5M Controller

Lambda 4S/5S controller provides up to 5 pulse feed driver interfaces for X/Y/Z, the fourth and fifth axes. Lambda 5M controller provides one pulse feed axis driver interface for pulse spindle. The interfaces are 15-pin D-type sockets, and the pin definition is as shown in Fig. 2-54.

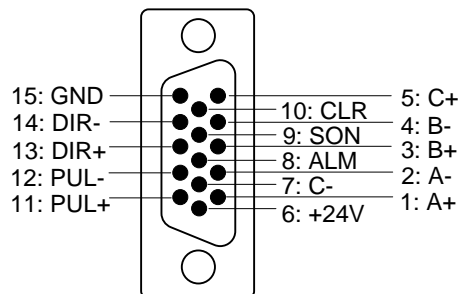

Fig. 2-54 Definition of driver interface



◆ Servo Driver Interface Definition

Name	Definition	Input /Output	Description
A+, A-	Feedback signal of encoder phase A	Input, differential signal transmission mode	Receive the differential output from encoder signal (phase A, B, C) of driver frequency divider (equaling to RS422).
B+, B-	Feedback signal of encoder phase B	Input, differential signal transmission mode	
C+, C-	Feedback signal of encoder phase C	Input, differential signal transmission mode	
ALM	Driver alarm signal	Input	When breakdown occurs in driver, the output (transistor) will be disconnected.
SON	Servo ON signal	Output	This signal is used for opening (power on) and closing (power off) servo motor. When this signal is connected to COM-, dynamic brake will be released and thus the driver is allowed to work (servo enabled).
CLR	Driver alarm clear signal	Output	This signal is used for alarm/warning status clear, and can only remove the alarms that can be removed.
PUL+, PUL-	Pulse output	Output, differential signal transmission mode	
DIR+, DIR-	Direction output	Output, differential signal transmission mode	
+24V, GND	DC 24V power	Output	Connected to driver



SON signal will be effective at 2 seconds after connecting of power supply. Don't try to drive the motor through external servo ON or servo OFF drive signal at any time, since the system controls the power-up state of the servo motor.

### 2.4.3 Lambda 5E Controller

Pins definitions of interfaces on Lambda 5E controller are as follows:

DIR differential signals (DIR+ and DIR-) of the controller receive SIGN+ and SIGN- signal from the driver respectively, used as pulse direction signals; meanwhile, DIR+ also can receive SEN signal from the driver, used as enabling (SRV-ON) signal of the absolute encoder. Note that pulse direction signal and enabling signal of the absolute encoder cannot be active at the same time. To put it in other words,

generally DIR differential signals are used as pulse direction signals at servo-ON, while as SEN signal at servo-OFF. See section 6.2.2 for wiring diagrams.

◆ **Servo Driver Interface Definition**

Name	Definition	Input /Output	Description
A+, A-	Feedback signal of encoder phase A	Input, differential signal transmission mode	Receive the differential output from encoder signal (phase A, B, C) of driver frequency divider (equaling to RS422).
B+, B-	Feedback signal of encoder phase B	Input, differential signal transmission mode	
C+, C-	Feedback signal of encoder phase C	Input, differential signal transmission mode	
ALM	Driver alarm signal	Input	When breakdown occurs in driver, the output (transistor) will be disconnected.
SON	Servo ON signal	Output	This signal is used for opening (power on) and closing (power off) servo motor. When this signal is connected to COM-, dynamic brake will be released and thus the driver is allowed to work (servo enabled).
CLR	Driver alarm clear signal	Output	This signal is used for alarm/warning status clear, and can only remove the alarms that can be removed.
PUL+, PUL-	Pulse output	Output, differential signal transmission mode	
DIR+, DIR-	Direction output	Output, differential signal transmission mode	DIR+ also can receive SEN signal from the driver, used as enabling (ON) signal of the absolute encoder.
+24V, GND	DC 24V power	Output	Connected to driver

## 2.5 MPG Interface

Lambda CNC system has a MPG (or called handwheel) interface for connecting with a handwheel up to 6 axes. You can buy MPGs from WEIHONG, or from other companies.

Our MPG interface is composed of dual-in line DB15 holes, and its pins definition is as shown in Fig. 2-55.

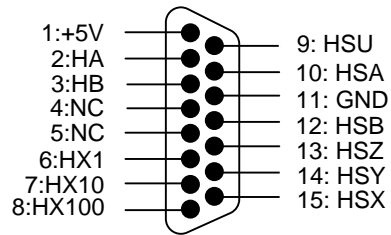

Fig. 2-55 Pins definition of MPG interface

### ◆ Definition of MPG interface

Pins No.	Function	Description
1	+5V	Power on handwheel
2	HA	Encoder phase A signal
3	HB	Encoder phase B signal
4	NC	
5	NC	
6	X1	X1 override
7	X10	X10 override
8	X100	X100 override
9	HSU	Selection of the fourth axis
10	HSA	Selection of the fifth axis
11	GND	Digital ground
12	HSB	Selection of the sixth axis
13	HSZ	Selection of Z-axis
14	HSY	Selection of Y-axis
15	HSX	Selection of X-axis

## 2.6 Extended Terminal Board Interface

The extended terminal board interface type of Lambda 4S controller is non-cascade connection type, while that of Lambda 5S controller is cascade connection type.

### 2.6.1 Cascade Connection

For cascade connection type, Lambda 5S controller should be connected with terminal board EX31A. N and P in Fig. 2-56 are the negative and positive polarities of two groups of differential signal respectively.

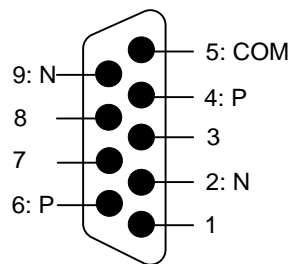

Fig. 2-56 Cascade connection type extended terminal board interface

### 2.6.2 Non-cascade Connection

For non-cascade connection type, Lambda 4S controller should be connected with terminal board EX27A. See Fig. 2-57 for pin connection to EX27A.

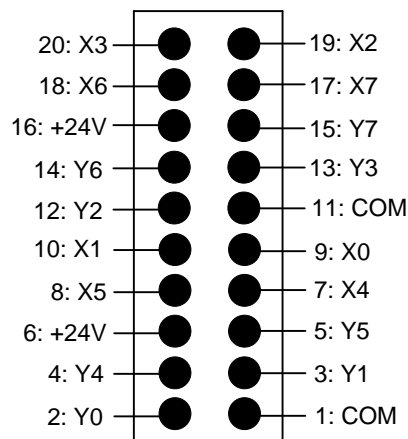

Fig. 2-57 Non-cascade connection type extended terminal board interface

## 2.7 Signal Types

### 2.7.1 Binary Input Signal

Binary input signals can be active low or active high. See Fig. 2-58. When S is connected to COM, inputs are active high, when to +24V, active low.

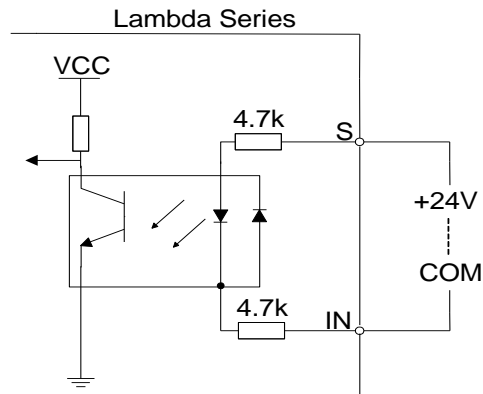

Fig. 2-58 Binary input connecting with mechanical switch

### 2.7.2 Relay Output Signal

The relay output contact points on Lambda series controllers have load capacity: 7A/250VAC and 7A/30VDC. If high power load is needed, a contactor can be used. See Fig. 2-59.

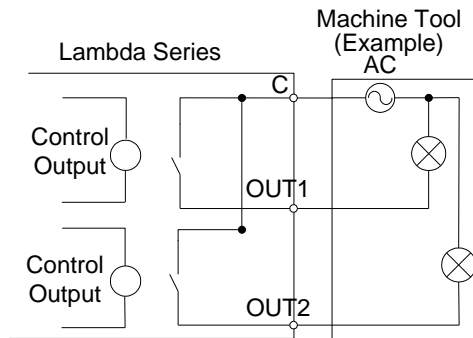

Fig. 2-59 Connection of relay output with contactor

### 2.7.3 Servo Enable Signal

This signal is used to activate (power on) and close (non-power on) servo motor. See Fig. 2-60.

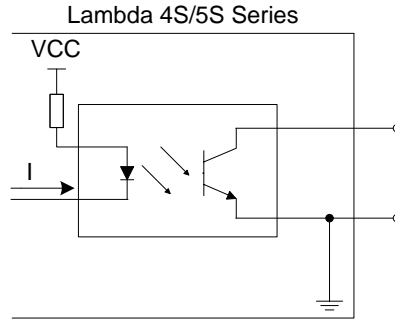

Fig. 2-60 Output circuit of servo enable signal

### 2.7.4 Encoder Signal

Servo interface receives differential output of encoder signal (phase A, B and C) from the frequency divider (equaling to RS422) of the driver. See Fig. 2-61.

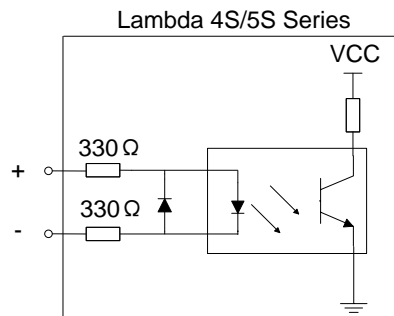

Fig. 2-61 Input circuit of encoder signal

### 2.7.5 Command Pulse Signal

Pulse command format to control driver motion is “pulse + direction, negative logic”. Its maximum pulse frequency is 1MHz and the pulse mode is as shown in Fig. 2-62.

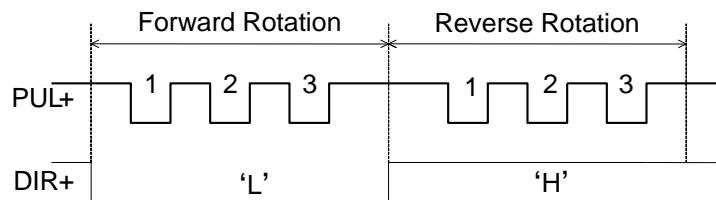

Fig. 2-62 Output type of pulse command

The output circuit of pulse command is as shown in Fig. 2-63.

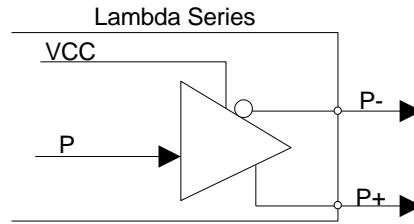

Fig. 2-63 Output circuit of pulse command

## 2.7.6 Analog Output Signal

SVC port, externally connected with the inverter analog voltage frequency command input port, outputs voltage controlled from 0V to 10V. And it controls spindle speed through voltage change causing inverter frequency change.

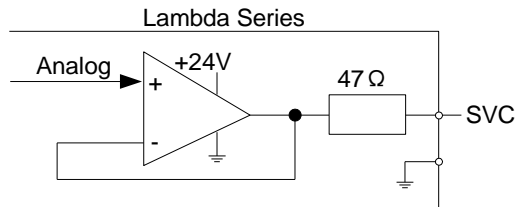



Fig. 2-64 Analog output signal circuit

## 3 Installation

---

### 3.1 PM85A/95A Communication Card

#### 3.1.1 Installation Steps

- 1) Insert the software CD into the CD driver of computer, double click  in the NcStudio software CD, and then install the software according to the prompts of the software installation wizard;
- 2) Power off the computer, open the computer chassis, insert the communication card into a PCI slot (for PM85A) or PCI-E slot (for PM95A), fasten the screw of rail block, and cover the computer chassis;
- 3) Power on the computer, the computer to find the new hardware-device automatically. And then install the driver manually according to the driver installation wizard;
- 4) Double click the shortcut icon of NcStudio on the desktop; if it runs normally, installation is completed (if the software fails, please check whether the communication card is well inserted and whether gold fingers are clean).

#### 3.1.2 Driver Update

If the system does not prompt finding a new device, you can update the driver manually by following the steps below:

- 1) Right click “My Computer”, select “Properties”, and click “Device Manager” under “Hardware” tab in the “System Properties” window. And then find “CNC Adapters” in the pop-up “Device Manager” window, right click the option under “CNC Adapters”, and select “Update Driver...” to start updating the hardware driver. A new window appears, as shown in Fig. 3-1.



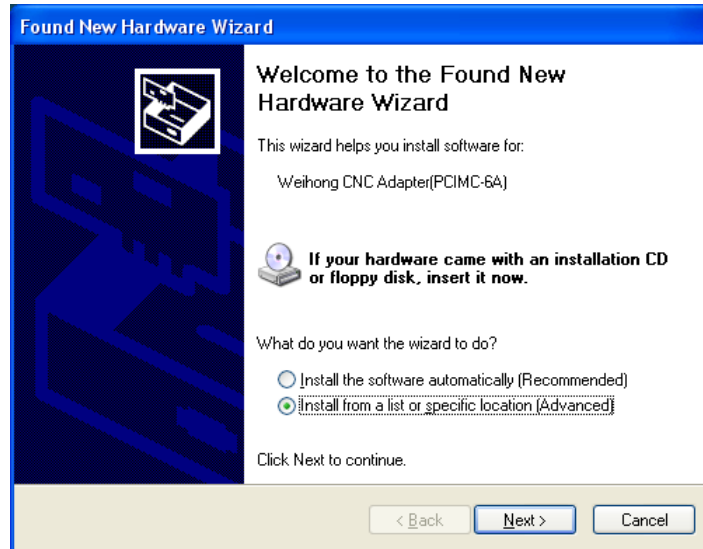

Fig. 3-1 Beginning of driver update

- 2) Select “Install from a list or specific location (Advanced)” in the pop-up “Found New Hardware Wizard”. And then click “Next”. See Fig. 3-2 for the new pop-up window.

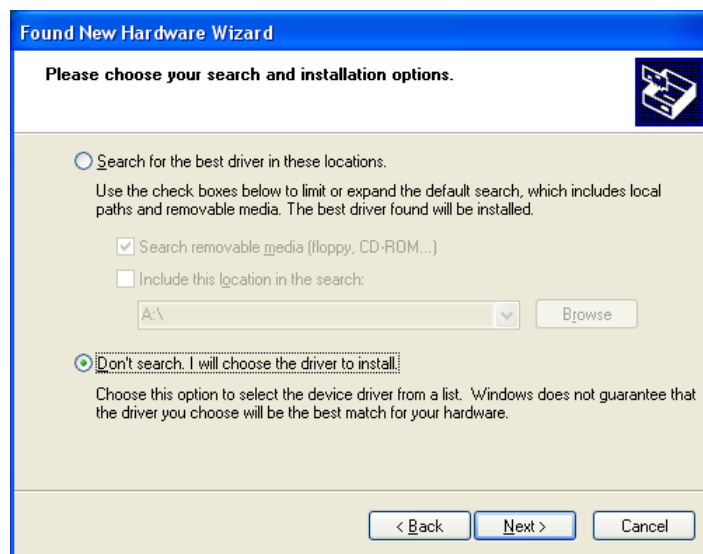

Fig. 3-2 Installation Options

- 3) Select “Don’t search. I will choose the driver to install”, and then click “Next”. See Fig. 3-3 for the new pop-up window.

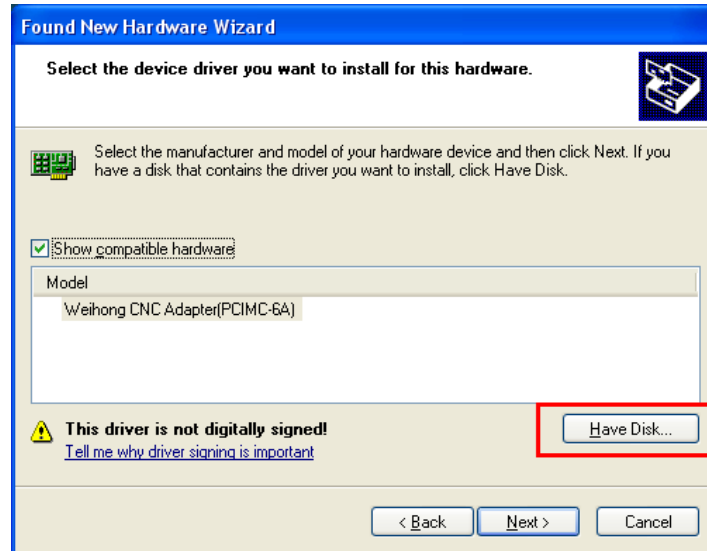

Fig. 3-3 Find driver location—1

4) Click “Have Disk...”, a new window to appear, as shown in Fig. 3-4.

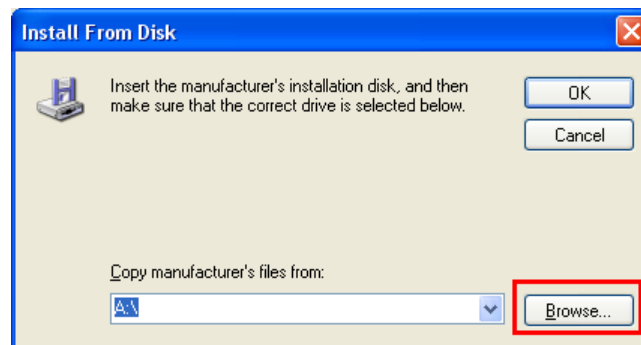

Fig. 3-4 Find driver location—2

5) Click the “Browse” button in the pop-up dialog “Install From Disk”, and select the target *Lambda.inf* file under “C:\Program Files\Naiky\PCIMC-Lambda”. (Here takes PM85A as an example)

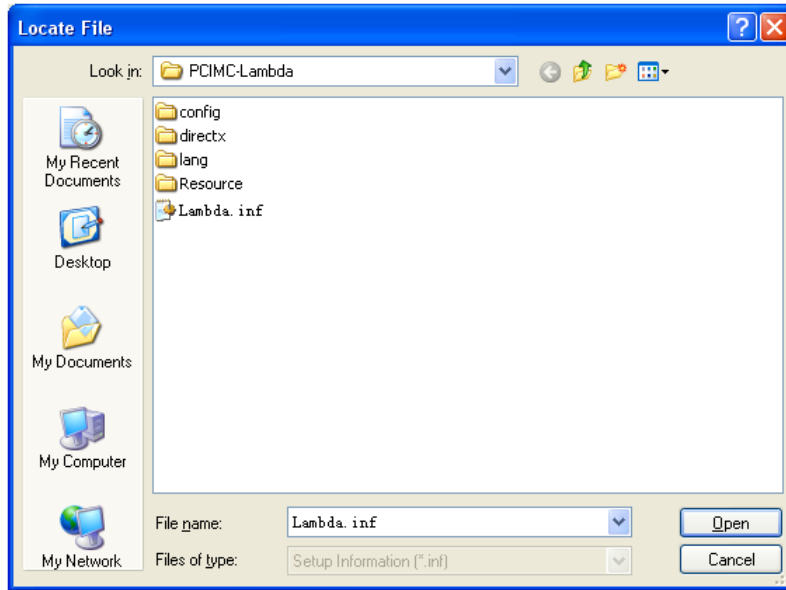

Fig. 3-5 Find driver location—3

- 6) After selecting the corresponding driver file, click “Open” to return to the previous page, showing the file directory under “Copy manufacturer’s files from”, as shown in Fig. 3-6.

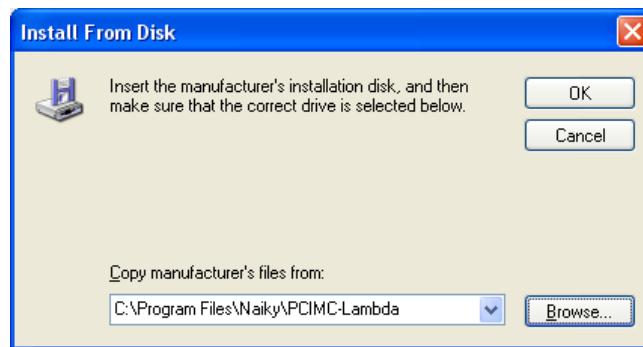

Fig. 3-6 Find driver location—4

- 7) Click “OK” to go back, and then click “Next” to start updating the hardware driver with the progress bar displayed. See Fig. 3-7.

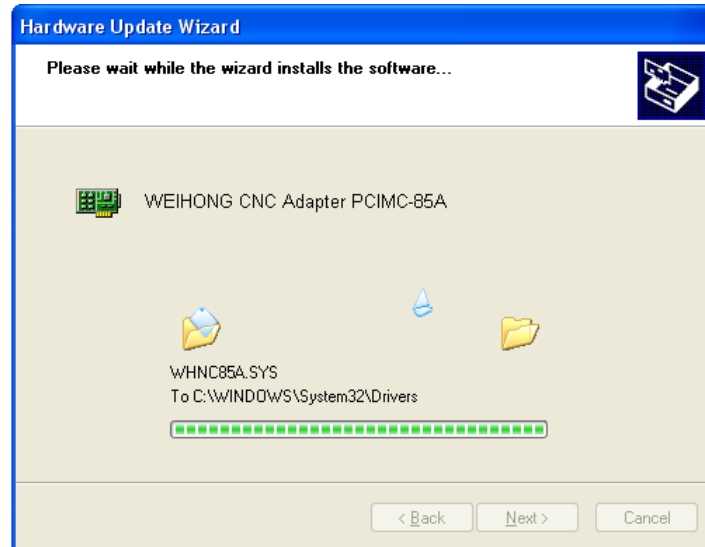

Fig. 3-7 Updating the driver

- 8) After updating completed, a new window, as shown in Fig. 3-8, appears. You just need to click “Finish” to complete the update of the hardware driver, and then you can open the software successfully.



Fig. 3-8 Update driver complete

### 3.1.3 Customization of Setup Installation Package

A tool, named NcHelper.exe under the installation directory, helps customize setup installation package. For example, when you want to change the settings of some parameters and set them to default value in the process of using NcStudio, to achieve the best performance of a machine tool, you can change the settings, find this tool, double click it, select a default configuration, and generate a new software package with the parameter settings changed.

## 3.2 NC65A/65B/65C Host

Before leaving factory, the NC65A/65B/65C integrated CNC system has already been installed with software. In case of software failure, you can re-install or update the software following the steps in 3.2.1.

### 3.2.1 Software Setup

- 1) Enter the desktop, and double click the desired software package. The first pop-up dialog is for language selection. See Fig. 3-9. Selecting “ENGLISH” will run the software in English. Likewise, if “选择中文界面” is selected, NcStudio will run in Chinese.



Fig. 3-9 Language selection

- 2) Setup continues after a language is selected. If the operating system has already been installed with NcStudio software, the installation package will delete the old files and give a prompt, as shown in Fig. 3-10. If “OK” is selected, the setup will continue. Otherwise, the setup will exit.

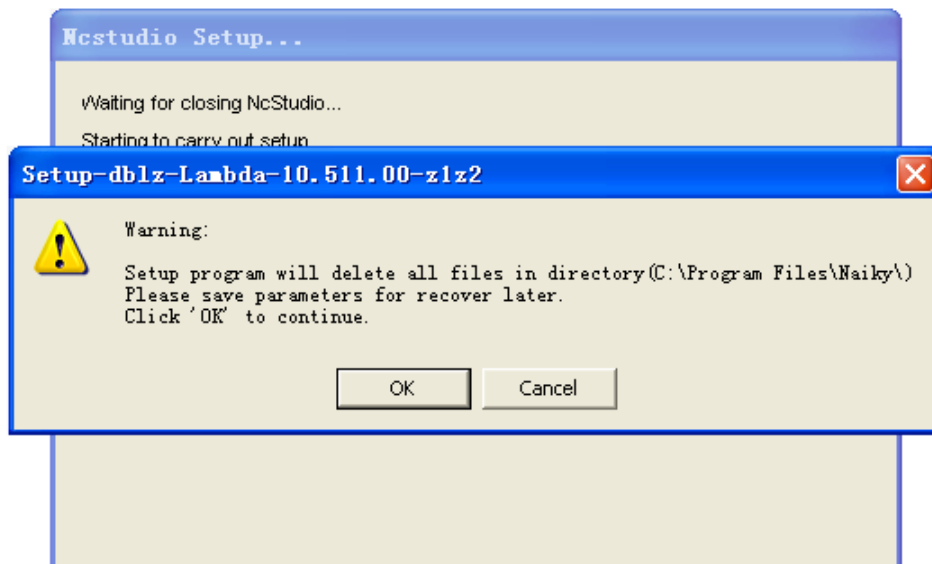

Fig. 3-10 Prompt to save parameters

- 3) Click “OK”. If software of old version has been installed in the host, a dialog box prompting parameter saving will appear, as shown in Fig. 3-11. The step can save trouble of re-set parameters again in the new software by keeping parameter settings of the old version software. You can select

“Yes” or “No” by your choice and continue the installation. Note that in first-time installation, this step is absent, please jump to step 4) directly to go ahead.

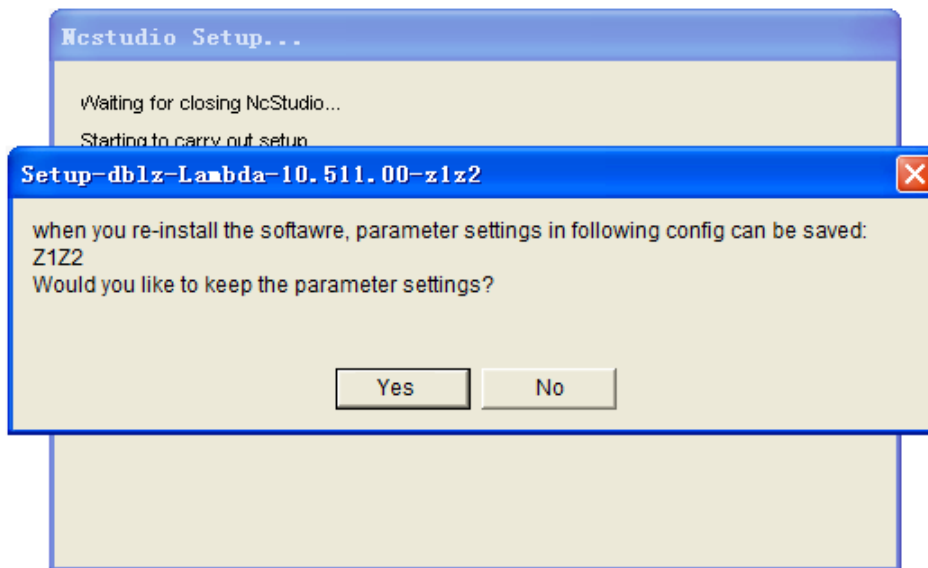

Fig. 3-11 Prompt for parameter saving

4) Installation begins. The progress bar is displayed as shown in Fig. 3-12.

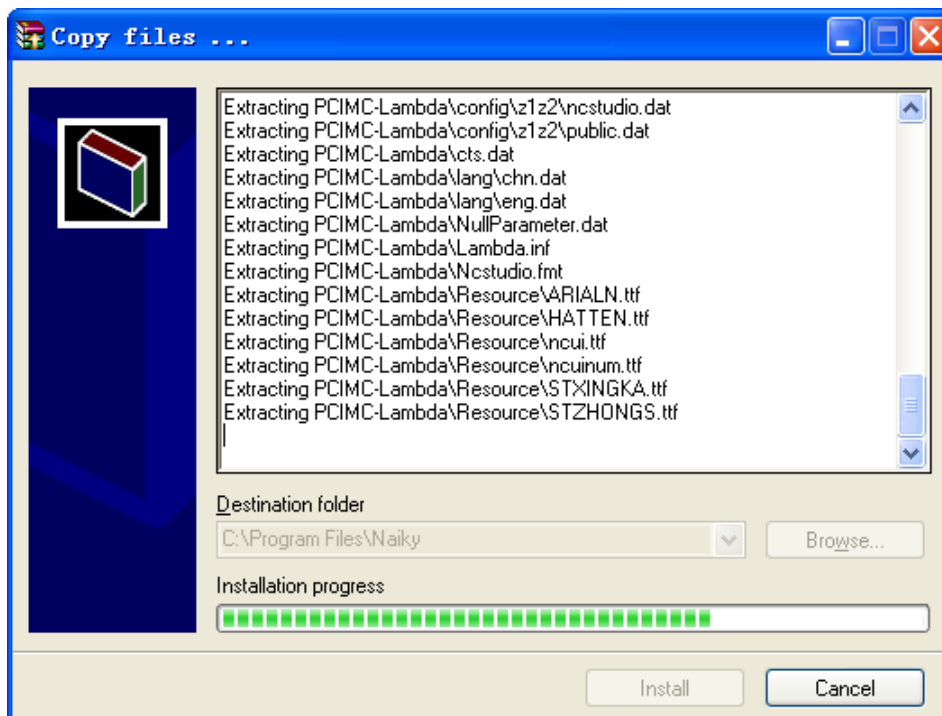

Fig. 3-12 Software setup progress

5) After setup completed, the system installs the driver automatically. See Fig. 3-13.

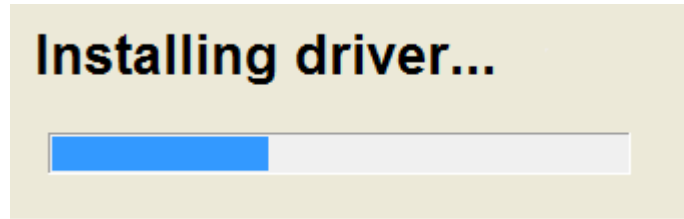

Fig. 3-13 Driver installation

- 6) After driver installation completed, a dialog box prompting “NcStudio installation is completed!” will pop up. Click “OK” to exit from the installation process.



Software installation process or software updating process of NC65A/65B/65C are the same in nature. While appearance styles of dialog boxes may differ in NC65C host because of Win8.1-32bit operating system.

## 3.2.2 OS Backup and Restore

The OS can be backed up and restored in NC65A/65B/65C, and the concrete steps are as following.

### 3.2.2.1 First-time OS Backup

- 1) Press F7 repeatedly at boot until entering the interface shown in Fig. 3-14.



Fig. 3-14 First-time backup interface

- 2) Select “1 分区 备份” (means Partition Backup) to start OS backup.
- 3) After backup completed, the OS before backup will be rebooted automatically.

### 3.2.2.2 Other Backups

- 1) Press F7 repeatedly at boot until entering the interface shown in Fig. 3-15.



Fig. 3-15 System restore

- 2) Select “取消(C)” (means Cancel) to enter the interface shown in Fig. 3-16.



Fig. 3-16 Backup interface under other conditions

- 3) Select “2 重新 备份” (means Re-backup) by Up and Down keys to start OS backup.  
 4) After backup completed, the OS before backup will be rebooted automatically.

### 3.2.2.3 OS Restore

- 1) Press F7 repeatedly at boot until entering the interface shown in Fig. 3-15.  
 2) Select “还原(R)” (means Restore) to start OS restore.  
 3) After restore completed, the fresh restored OS will be booted automatically.



Selecting “1 分区 还原” (means Partition Restore) in Fig. 3-15 will also execute OS restore.



## 3.2.3 OS Backup and Restore via USB Flash Disk

If OS failed and cannot be backed up or restored following the above steps, you can execute OS backup and restore by creating an USB startup disk.

### 3.2.3.1 Preparation

- 1) An USB flash disk (above 1G)
- 2) The backup and restore kit

### 3.2.3.2 Setup

#### ◆ Creating USB Startup Disk

Double click “hpUpgsh\hpUpgsh.exe” under the designated file folder. As shown in Fig. 3-17, a dialog pops up. Select the drive letter, file system, format options and the path of boot files (H:\hpUpgsh\boot) in this dialog, and then select “Start” to begin formatting. Keep selecting “Yes” until the making of USB startup disk finishes.

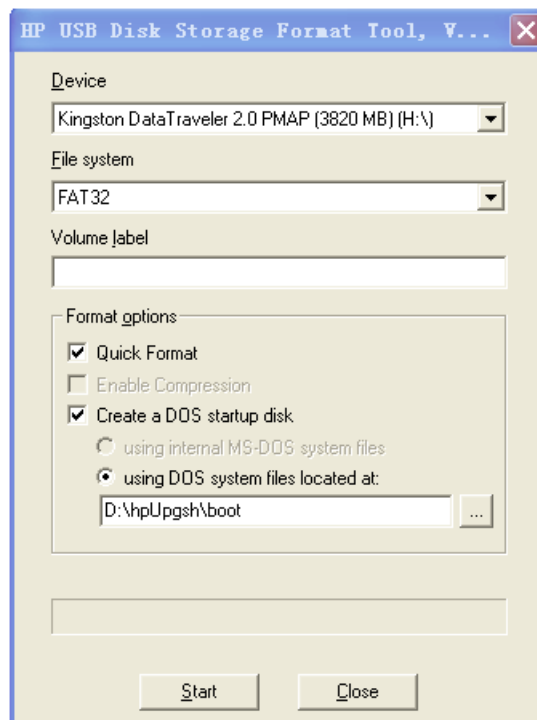

Fig. 3-17 The interface to make a USB startup disk

#### ◆ Tool Kit Installation

After creating the USB startup disk successfully, double click the installation package file “WEIHONG-NC65A/65B-XP-V\*.exe”. Select “浏览(W)...” (means Browse), and define “目标文件夹”

(means Destination Folder) as the root directory of the USB flash disk. And then click “安装” (means Install) to start extracting, as shown in Fig. 3-18.

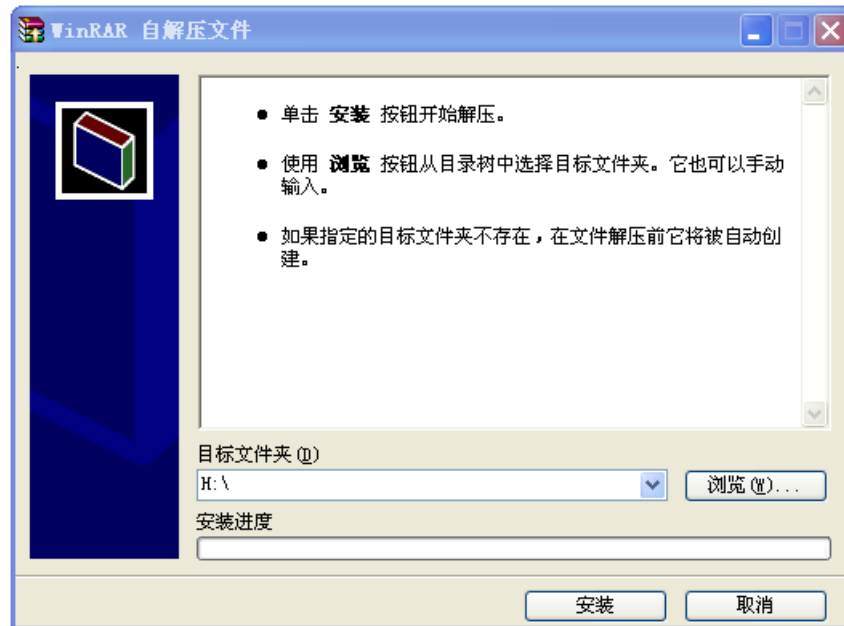

Fig. 3-18 Setup

After extraction finishes successfully, the setup of backup and restore kit is completed.

### 3.2.3.3 OS Backup and Restore

#### ◆ Setting BIOS Booting from USB Flash Disk and the Sequence of System Disk and Data Disk

Insert the startup disk with the OS backup file into the NC65A/65B/65C host, and then reboot the NC65A/65B/65C, while pressing the “Delete” key to enter BIOS. Select “Advanced Bios Features →Hard Disk Boot Priority” to set the disk sequence: U 盘设备(means USB flash disk)/Cho M/Cho S/; (note: for start-up the OS, the sequence must be Cho M/ Cho S). Otherwise, OS restore and backup may aim at the data disk.

#### ◆ One-key Restore

After entering the one-key restore DOS environment by booting from the USB flash disk, there are two options. Continuously pressing “1” twice will make the tool kit restore the OS automatically. After restoring, remember to reset BIOS “Hard Disk Boot Priority” before removing the USB flash disk. Then the OS can be rebooted.



After restore process completed, it is required to reboot the system in a normal way before installing the software, because write-protect is not enabled after the OS is installed for the first time. After rebooting, write-protect is opened.

### ◆ One-key Backup

Select “2” to return to DOS environment after entering environment selection by booting from the USB flash disk. Input “back”, and then press “Enter” to enter backup selection environment. Selecting “2” will enter into backup state automatically. If there is already the image file “diskback.gho” in the USB flash disk, remember to rename it or cut it before one-key backup. Otherwise, the tool kit will exit from backup environment automatically if the image file has already existed in the USB flash disk.



If abnormal conditions occur during system restore and backup, the most possible causes are as following:

- 1) The boot sequence of BIOS hard disk is wrong.
- 2) The OS has already been broken before backup.
- 3) The USB space is not enough.
- 4) The image file has already existed in the USB in the process of backup.
- 5) Sometimes, if backup or restore exits abnormally, it is possible that there are bad sectors in the system CF card. The way to solve it is to repair the hard disk of CF card.
- 6) On account of the above issues, it is suggested to check and repair the system disk before OS restore and backup, or system performance may be affected, so is the data disk.

# 4 Machine Tool Debugging

## 4.1 Debugging Steps

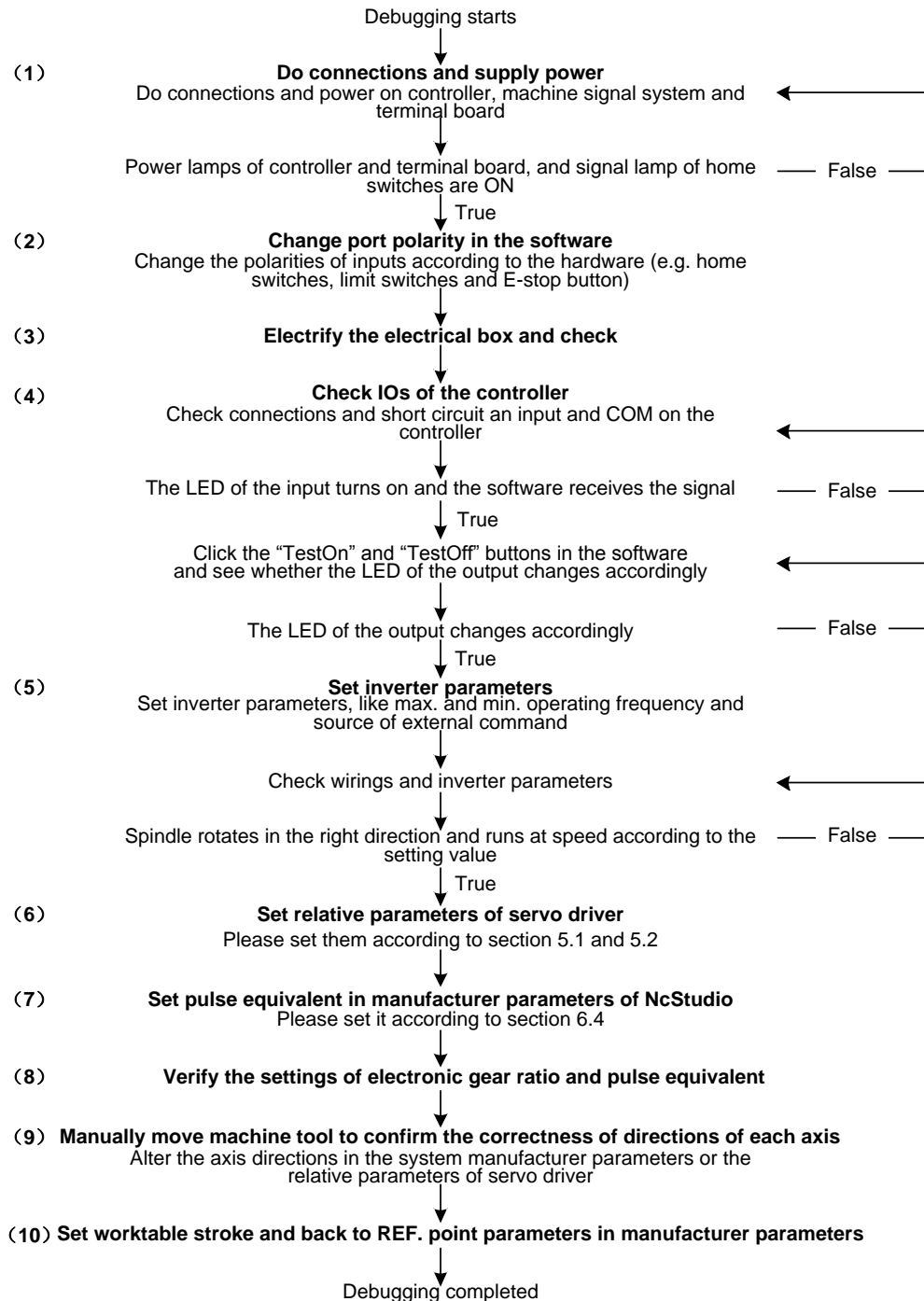
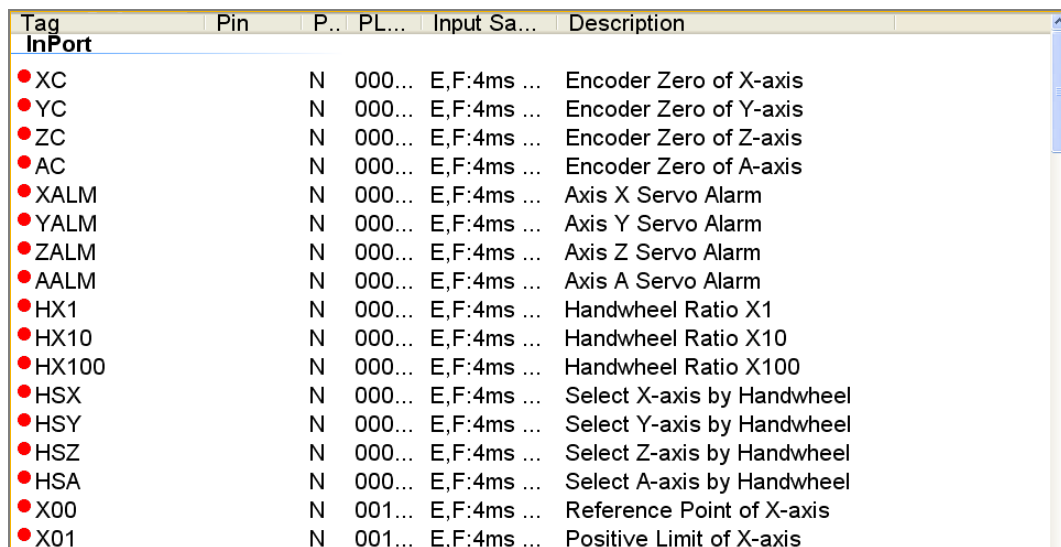

Fig. 4-1 Process of machine tool debugging

The above process is for preliminary debugging, see below for detailed steps:

- 1) Connect the Lambda controller to the communication card or NC65A/65B/65C host with a DB9M/F cable, provide 24V power supply for the controller, check whether the power indicator on the controller is on, and power on the machine signal system (proximity switch, etc). If the home switches connected are normally closed, at this time, three LEDs of X0, Y0 and Z0 should be on. Trigger a home switch through artificial imitation. (For a travel switch, artificial press can be used to observe whether the signals can be received. For a photoelectrical switch, artificially obstruct the light to see if the signals can be gotten. For a metal proximity switch, artificially approach it with a metal block to see if the signals can be gotten.) If the corresponding LED is out, it indicates the REF. point signals have been sent to the controller. If the home switches connected are normally open, LEDs should be usually out, and by artificially touching a switch, the LED should light, which shows the REF. point signals have been sent to the controller. The same method can be taken to test other input ports to ensure the correctness of the wiring between the controller and the machine tool, to greatly shorten the debugging time.
- 2) Power on the computer, run NcStudio software, and then switch to “DIAG”→ IOPort” window, displaying input and output signals (in dual Z axes software, switch to “IOPort”). Solid dots indicate input signals, while hollow dots output signals; dots in red indicate the signals are invalid at the time (with no input or output), while dots in green indicate valid at the time. The “IOPort” window is as shown in Fig. 4-2. (It is for reference only. Ports displayed in the “IOPort” window vary with software version and hardware. The actual situation is in line with shipment).



Tag	Pin	P..	PL...	Input Sa...	Description
<b>InPort</b>					
● XC		N	000...	E,F:4ms ...	Encoder Zero of X-axis
● YC		N	000...	E,F:4ms ...	Encoder Zero of Y-axis
● ZC		N	000...	E,F:4ms ...	Encoder Zero of Z-axis
● AC		N	000...	E,F:4ms ...	Encoder Zero of A-axis
● XALM		N	000...	E,F:4ms ...	Axis X Servo Alarm
● YALM		N	000...	E,F:4ms ...	Axis Y Servo Alarm
● ZALM		N	000...	E,F:4ms ...	Axis Z Servo Alarm
● AALM		N	000...	E,F:4ms ...	Axis A Servo Alarm
● HX1		N	000...	E,F:4ms ...	Handwheel Ratio X1
● HX10		N	000...	E,F:4ms ...	Handwheel Ratio X10
● HX100		N	000...	E,F:4ms ...	Handwheel Ratio X100
● HSX		N	000...	E,F:4ms ...	Select X-axis by Handwheel
● HSY		N	000...	E,F:4ms ...	Select Y-axis by Handwheel
● HSZ		N	000...	E,F:4ms ...	Select Z-axis by Handwheel
● HSA		N	000...	E,F:4ms ...	Select A-axis by Handwheel
● X00		N	001...	E,F:4ms ...	Reference Point of X-axis
● X01		N	001...	E,F:4ms ...	Positive Limit of X-axis

Fig. 4-2 NcStudio I/O ports window

- 3) Alter the input port polarity of the software in terms of the home switches and E-STOP button used: the polarity of NO input ports is N, while that of NC input ports is P. The way to alter the polarity is as follows:

In V8 version: press Ctrl, Alt and Shift simultaneously, while right clicking the signal to be modified its polarity, a menu to appear, and then choose “Toggle Polarity”. After changing the polarity of all desired ports, restart NcStudio, polarity modification to become valid instantly.

In V9 and V10 versions: directly click the manipulation button [ConvPol] under [IOPort] screen of [DIAG] function section. After changing the polarity of all desired ports, close and restart NcStudio, polarity modification to become valid instantly.

- 4) Electrify the electrical box. At this time, the dots in front of such input signals as REF. point signals of the three axes, E-STOP signal, cycle start/stop signals and tool sensor signal should be in red, indicating all these signals are invalid. Otherwise, it is necessary to check the correctness of electrical circuitry and signals polarity. If electrical circuitry is correct, alter the corresponding signal polarity to ensure the dots in front of the above-mentioned signals red.
- 5) Test whether the inputs and outputs on the controller work normally. For an input, the method is as following: short circuit an input and COM on the controller: if the corresponding LED on the controller turns on, but the corresponding input in the software does not have the signal, you need to check the connection of the cable DB9M/F between the communication card (NC65A/65B/65C host) and the controller. If the LED does not turn on, you need to check whether the controller meets a fault (like power supply issue). For an output, the method is as following: click the “TestOn” and “TestOff” buttons in the software, and observe whether the corresponding LED on the controller turns on or off accordingly. If so, the output works normally; if not, check the connection of the cable DB9M/F between the communication card (NC65A/65B/65C host) and the controller.
- 6) Set inverter parameters to make the inverter work under 0~10V analog voltage control mode. Spindle ON/OFF adopts forward rotation terminal control mode. Press down the [Spindle Start] button in the software, and observe in the IOPort window whether the color of signal dot in front of “Spindle” turns green, on the controller whether the green output indicator LED beside the corresponding relay becomes brightening, and whether the spindle starts to rotate. If the spindle does not rotate, please examine the connection of the inverter. Adjust the spindle speed in the software and the actual spindle speed should be changed correspondingly; otherwise, examine the connection and the parameters setting of the inverter. If the spindle rotates in a wrong direction, you can change the settings of the relative inverter parameters, or change the connection between the spindle and inverter: usually, there are three wires connected with the spindle. Exchanging any two of them will alter the spindle rotation direction.
- 7) Set the relative parameters of servo driver. Refer to section 5 for the setting of driver parameters.
- 8) Set pulse equivalent in the “manufacturer parameters” of Ncstudio. The password of manufacturer parameters is “ncstudio”. The smaller the pulse equivalent is, the higher the resolution will be. The value of pulse equivalent will affect the maximum feed speed. Generally speaking, regarding the pulse equivalent of a mold machine, 0.001mm/p (the corresponding maximum feed rate is 9600mm/min) or 0.0005mm/p (the corresponding maximum feed rate is 4800mm/min) can be taken into consideration; for users who are not very critical of the accuracy, the pulse equivalent can be set a litter larger, such as 0.002mm/p (the corresponding maximum feed rate is 19200mm/min) or 0.005mm/p (the corresponding max. feed rate is 48000mm/min). When pulse equivalent is confirmed, calculate the electronic gear ratio of servo driver in terms of value of pulse equivalent. Refer to section 6.4 for the calculation of electronic gear ratio.

- 9) Examine whether the value of electronic gear matches with that of pulse equivalent. Make a mark on any axis of the machine tool and set this marked point as the workpiece zero. Drive this marked axis to move a fixed distance by direct command input, jog or handwheel, and so on. Measure the actual moving distance with a vernier caliper and check whether the result is equal to the distance showed in the software.
- 10) Move the machine tool manually to make sure the correctness of moving direction of each axis. Note that NcStudio adopts “right hand” coordinate system. For X-axis, right movement is the positive direction; for Z-axis, upward movement the positive direction; while the positive direction of Y-axis is to move away from the operator (if the movement of Y-axis is the movement of worktable, its positive direction is the worktable moving towards the operator). If the direction is not correct, alter the axis direction in the system parameters or the relative parameters of servo driver. If Z-axis has brake, check the relative wiring of brake and the relative parameters of servo driver before Z-axis starts to move for the first time. After confirmation, move Z-axis in jog mode at a slow speed, and observe the response of Z-axis, making sure the brake can be opened normally.
- 11) Set the worktable stroke in the manufacturer parameters according to the actual size of the machine tool to enable software limit function.
- 12) Set “Back to Machine Zero” parameter in manufacturer parameters according to the installation position of home switches of the three axes. After correct setting, perform the “Back to Machine Zero” function under menu “Operate”. At first, home a single axis. Home the other two axes on condition that the moving direction of the first axis is correct; otherwise, stop homing and revise “The Direction of Backing to Machine Zero” parameter in the manufacturer parameters until all axes can return to the machine zero.
- 13) Axial acceleration: it is used to describe the acceleration / deceleration ability of a single axis, in  $\text{mm/s}^2$ . The value is determined by the physical characteristic of the machine tool, such as quality of movement part, torque, resistance, cutting load of feed-motor, and so on. The larger the value is, the less time spent in the process of acceleration / deceleration will be, and the higher the efficiency will be. Generally, for a stepping motor system, the value is between 100 and 500; for a servo motor system, the value is between 400 and 1200. Set the value smaller at the beginning; make the machine tool perform various typical movements for a period of time, and carefully observe it; when there is no abnormal situation, increase the value gradually; otherwise, decrease the value and reserve 50% ~ 100% insurance allowance.
- 14) Turning acceleration: it is used to describe the acceleration/deceleration ability in synchronized motion of multi-axis, in  $\text{mm/s}^2$ . The value limits the maximum speed of the machine tool in circular movement. The larger this value is, the higher the maximum allowable speed on circular movement of the machine tool will be. Generally, for a stepping motor system, the value is between 400 and 1000; for a servo motor system, the value is between 1000 and 5000; for a heavy machine tool, the value should be smaller. Set the value smaller at the beginning; make the machine tool perform various typical movements for a period of time, and carefully observe it; when there is no abnormal situation, increase the value gradually; otherwise, decrease the value and reserve 50% ~ 100% insurance allowance.

Usually, given the drive ability of servo motor, friction of machine assembly, and endurance capacity of mechanical components, limit the maximum speed of the three axes in actual using by modifying the max. speed of each axis in the manufacturer parameters.

15) Set the parameter of auto lubrication (set a value smaller, such as once every 5 seconds). Observe if auto lubrication is executed correctly. If so, set it according to the actual need.

In case of any problem in the running of the machine tool, check every part carefully according to the steps above.



For a stepping motor system, start-up speed should be set between 200 and 300.

## 4.2 Pulse Test

If you suspect there is pulse loss, you can confirm it by either of the following two methods.

### 4.2.1 Stepping Driver

Mark a little dot on the surface of a workpiece blank with a dagger; set this point as the workpiece zero; lift up Z-axis; set the coordinate of Z-axis as 0; repeatedly move the machine tool, for example, run a typical procedure with no tools (including synchronized movement of the three axes is much better), and pause or stop during machining is permitted; and then back to the workpiece zero; descend Z-axis slowly; observe whether the knifepoint matches with the marked dot.

### 4.2.2 Servo Driver

For a servo system, there is a more precise method: set servo driver mode as “input pulse count mode” in the “surveillance mode” (for example, the parameter of YASKAWA servo is UN00C); regulate it to display the lower 4 bits (with “L” before the count value) in count value (hexadecimal system); set workpiece zero and then write down the pulse count value, then repeatedly run the procedure with no tools on the machine tool, then back to the workpiece zero and see whether the pulse count value at this time is the same with the original value.



For YASKAWA servo, as long as the value difference of pulse count value is no more than 4 (the frequency of host controller is 1/4 times the frequency of pulse sent by servo drive), indicating that the main controller sends the pulse within tolerance of 1 pulse, the control system runs normally; otherwise, please check the pulse signal type of servo driver, and make the pulse type received by servo in accord with pulse type sent by the system.



# 5 Driver Parameter Settings and Wiring Diagrams

Driver parameters listed in the following chapters can only ensure normal working of a machine tool, without ensuring machining results. To get a better machining result, you need to set those parameters according to actual situations.

## 5.1 Driver Parameter Setting (Lambda 3S/3L)

### 5.1.1 Parameter Setting of WISE Servo Driver

Para. No.	Function	Value	Description
Pr528	LED initial status	6	Monitor if the number of sent and received pulses is correct by setting this parameter. In Weihong control system, the correct quantity of pulses sent by control card is detected by pulse inspection in order to determine whether there is electrical interference.
Pr008	Command pulse No. per motor circle	0	When it is set to "0", parameters Pr009 and Pr010 are valid.
Pr009	1st numerator of command pulse frequency division/multiplication	Need calculation	Range: $0 \sim 2^{30}$ Typical value: pitch 5 mm, encoder resolution 10000, deceleration ratio 1:1, pulse equivalent 0.001 mm:
Pr010	Denominator of command pulse frequency division/multiplication	Need calculation	Pr009=10000 Pr010=pitch 5mm/ pulse equivalent 0.001mm=5000 Pr009/Pr010=10000/5000=2/1
Pr100	1st position loop gain	480 (default)	Unit: 0.1/s. Set it according to the actual situation.
Pr101	1st velocity loop gain	270 (default)	Unit: 0.1Hz. Set it according to the actual situation.

Para. No.	Function	Value	Description
<b>Pr102</b>	1st velocity loop integrated time constant	210 (default)	Unit: 0.1ms. Set it according to the actual situation.
<p>When the value of Pr008 is not "0", it can be calculated in terms of the following formula:</p> $\text{Command pulse No. per motor circle} = \frac{\text{Screw pitch}}{\text{Pulse equivalent} \times \text{Mechanical deceleration ratio}} = \frac{5\text{mm}}{0.001\text{mm}/p} = 5000$ <p>When pitch is 5mm and pulse equivalent 0.001mm/p, the value of Pr008 is "5000".</p>			

◆ Attached List: the relationship among parameters Pr008, Pr009 and Pr010.

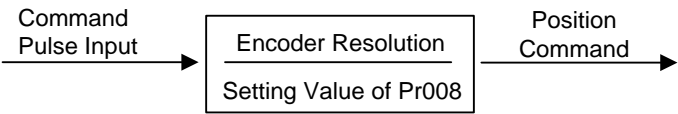
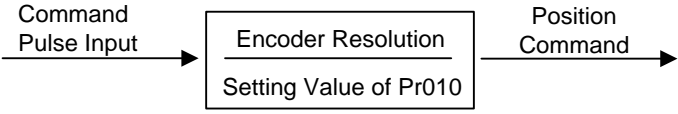
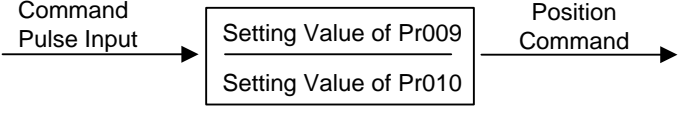
Pr008	Pr009	Pr010	Description
1~2 <sup>20</sup>	– (no influence)	– (no influence)	 <p>As shown above, the process is undergone in terms of the setting value of Pr008, not affected by the settings of Pr009 and Pr010.</p>
0	0	1~2 <sup>30</sup>	 <p>When the values of Pr008 and Pr009 are both set to "0", as shown above, the process is undergone in terms of the setting value of Pr010.</p>
	1~2 <sup>30</sup>	1~2 <sup>30</sup>	 <p>When the value of Pr008 is "0", but the value of Pr009 is not "0", as shown above, the process is undergone in terms of the setting values of Pr009 and Pr010.</p>

## 5.1.2 Parameter Setting of YASKAWA $\Sigma$ -II Servo Driver

Para. No.	Function	Value	Description		
<b>Un00C</b>	Surveillance mode	LXXXX (Hexadecimal system)	Monitor if the number of sent and received pulses is correct by setting this parameter. In Weihong control system, the correct quantity of pulses sent by control card is detected by pulse inspection in order to determine whether there is electrical interference.		
<b>Pn000</b>	Direction selection Control mode selection	0010	Bit 0: Set 0, "CCW" is forward rotation (viewed from the load end of screw ball); Set 1, the rotation direction of the motor is reversed. Bit 1: Set 1, position control mode (calculate pulse instruction all the time).		
<b>Pn001</b>	Selection servo off or alarm stop mode	XXX0	Bit 0: Set "0", stopping the motor by applying dynamic brake(DB) which will be maintained after stop; Set "1", stopping the motor by applying dynamic brake(DB) and then the motor can rotate freely after stop.		
<b>Pn200</b>	Select pulse instruction mode	0005	Bit 0: Set 5, select the instruction input mode as "pulse + direction", negative logic. Bit 3: Set 0, input differential signal into filter.		
<b>Pn201</b>	Encoder cycle-divided ratio (Pulses output per motor cycle by encoder after cycle-divided)	Right-side	Gain Encoder	Type	Encoder Pulse No. per Motor Circle (pulse/ revolution)
				A	13bit 2048
				B	16bit 16384
				C	17bit 32768
<b>Pn202</b>	Electronic gear ratio (numerator)	Need Calculation	Pn202 = pulse No. of each encoder circle $\times$ 4 $\times$ mechanical deceleration ratio. Pn203 = (screw pitch/ pulse equivalent).		
<b>Pn203</b>	Electronic gear ratio (denominator)	Need Calculation	Typical value: pitch 5mm, encoder 17-bit, deceleration ratio 1:1, pulse equivalent 0.001mm/p, Pn202=16384; Pn203=625. Pitch 5mm, encoder 17-bit, deceleration ratio 1:1, pulse equivalent 0.0005mm/p, Pn202=8192; Pn203=625.		

### 5.1.3 Parameter Setting of DELTA ASDA-A Servo Driver

Para. No.	Function	Format & Range	Value	Description
P0-02	Driver status display		02	Monitor if the number of sent and received pulses is correct by setting this parameter. In Weihong control system, the correct quantity of pulses sent by control card is detected by pulse inspection to determine if there is electrical interference.
P1-00	External pulse input type	ZYX	102	X=2: pulse + direction; Z=1: negative logic
P1-01	Control mode setup	ZYX1X0	0000	Z=0: during control mode switching, DIO is maintaining the set value. Since switching control mode is not used, Z=0 Y=0: forward rotation (CCW) (in terms of load); Y=1: the rotation direction is reversed. X1X0=00: position control mode
P1-44	Electronic Gear Ratio (Numerator)(N1)	1~32767	Need calculation	$N1/M = \text{encoder pulses} \times 4 \times \text{pulse equivalent} \times \text{mechanical deceleration ratio} / \text{pitch}$
P1-45	Electronic Gear Ratio (Denominator) (M)	1~32767	Need calculation	Representative value: encoder pulses=2500, pitch=5mm, pulse equivalent=0.001mm/p, deceleration ratio=1, calculation as below: $N1/M = 2500 \times 4 \times 0.001 / 5 = 2 / 1$ , N1=2, M=1; When the multi-electronic gear ratio is not used, P2-60~ P2-62 are not required.
P2-51	Servo ON (SON) setup		0	0: Servo ON must be triggered by numerical input signal. 1: when servo is powered, if there is no alarm signal, servo will be automatically on. Set 1 when there is no SON signal wire.

## 5.1.4 Parameter Setting of DELTA ASDA-B Servo Driver

Para. No.	Function	Format & Range	Value	Description
P0-02	Driver status display		02	Monitor if the number of sent and received pulses is correct by setting this parameter. In Weihong control system, the correct quantity of pulses sent by control card is detected by pulse inspection in order to determine whether there is electrical interference.
P1-00	External pulse train input type	ZYX	102	X=2: pulse + direction; Z=1: negative logic
P1-01	Set control mode	YX1X0	000	Y=0: forward rotation (CCW) (from the view of load); Y=1: the rotation direction is reversed. X1X0=00: position control mode
P1-32	Motor stop mode	YX	00	Y=0: when there is no servo enabled, motor dynamic brake occurs; Y=1: motor is free. X=0: motor stops instantly, X=1: motor stops with deceleration.
P1-44	Electronic Gear Ratio (Numerator)(N1)	1~32767	Need calculation	<p>N1/M= mechanical deceleration ratio × 4 × encoder pulses × pulse equivalent / pitch.</p> <p>Representative value: encoder pulses=2500, pitch =5mm, pulse equivalent=0.001 mm/p, deceleration ratio = 1, calculation as below:</p> $N1 / M = 2500 \times 4 \times 0.001 / 5 = 2/1, N1=2, M=1;$ <p>When the multi-electronic gear ratio is not used, P2-60 ~P2-62 are not required.</p>
P1-45	Electronic Gear Ratio (Denominator)(M)	1~32767	Need calculation	
P2-30	Servo ON (SON) setup		0	0: Servo ON must be triggered by numerical input signal. 1: when servo is powered, if there is no alarm signal, servo will be automatically on. Set 1 when there is no SON signal wire.

## 5.1.5 Parameter Setting of Panasonic MINAS A4 Servo Driver

Para. No.	Function	Value	Description
<b>Pr01</b>	LED initial status	12	Monitor if the number of sent and received pulses is correct by setting this parameter. In Weihong control system, the correct quantity of pulses sent by control card is detected by pulse inspection in order to determine whether there is electrical interference.
<b>Pr02</b>	Select control mode	0	0: position mode 1: velocity mode 2: torque mode
<b>Pr40</b>	Selection of command pulse input	1	1: input by differential exclusive circuit
<b>Pr42</b>	Select command pulse input mode	3	Set command pulse input mode: command pulse + command direction, negative logic
<b>Pr48</b>	1st numerator of command pulse frequency multiplication	Need calculation	Range: 1~10000. Typical value: pitch 5 mm, encoder resolution 10000, deceleration ratio 1:1, pulse equivalent 0.001mm/p:
<b>Pr4B</b>	Denominator of the command pulse frequency multiplication	Need calculation	Pr48=10000 Pr4B=pitch/pulse equivalent=5000 Pr48/Pr4B=10000/5000=2/1

## 5.1.6 Parameter Setting of MITSUBISHI MR-E Servo Driver

Para. No.	Code	Function	Value	Description
0	*STY	Select control mode and regenerative fittings	X0X0	Bit 0, set 0: select position control mode. Bit 1, select motor series: 0: HC-KFE; 1:HC-SFE; Bit 3, select regenerative apparatus, and set 0: not use. Bit 4, select motor power.
3	CMX	Electronic gear numerator	Need calculation	CMX/CDV=command unit × servo motor resolution × mechanical deceleration ratio / pitch. E.G., pitch 5 mm, encoder resolution 10000,deceleration ratio 1:1, pulse equivalent 0.001 mm/p, CMX/CDV=10000×0.001/5 = 2/1; When pulse equivalent = 0.0005mm/p, CMX/CDV = 1/1. Electronic gear ratio range: 1/50 ~ 500
4	CDV	Electronic gear denominator	Need calculation	
18	*DMD	Status display selection	00XX	3: cumulative command pulses E: load inertia When the parameter is set [3], monitor if the number of sent and received pulses is correct by setting this parameter. In Weihong control system, the correct quantity of pulses sent by control card is detected by pulse inspection to determine if there is electrical interference.
21	*OP3	Function selection 3 (command pulse format selection)	0001	Set pulse command input form: pulse train+ sign, negative logic
41	*DIA	Signal input SON-ON, LSP-ON and LSN-ON automatically selection	0110	Bit 0: Servo-ON selection. [0]: servo on by external input; [1]: servo on all the time inside. Bit 1: last signal of positive rotation range (LSP): [1]: auto servo on inside, without external wiring. Bit 3: last signal of negative rotation range (LSN): [1]: auto servo on inside and no need of external wiring.



- 1) Both positional control mode and velocity control mode are supported for MR-E-A series servo drivers.
- 2) Only velocity control mode (analog input) is supported for MR-E-AG series servo drivers.







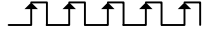

### 5.1.7 Parameter Setting of FUJI FALDIC- $\beta$ Servo Driver

Para. No.	Name	Value	Description
01	Command pulse numerator $\alpha$	Need calculation 1~32767	Command pulse numerator and denominator are equal to those of the electronic gear ratio. $\alpha / \beta = \text{encoder resolution} \times \text{pulse equivalent} \times \text{mechanical deceleration ratio} / \text{screw pitch}$ .
02	Command pulse denominator $\beta$	Need calculation 1~32767	Typical value: encoder resolution 65536, pitch 5mm, pulse equivalent 0.001mm/p, mechanical deceleration ratio 1, $\alpha / \beta = 65536 \times 0.001 / 5 = 8192 / 625$ , So $\alpha = 8192$ , $\beta = 625$ .
03	Pulse string input form	0	Set the input mode of pulse string as: instruction + symbol, that is 'pulse + direction'.
04	Direction of rotation switch	0 or 1	Set 0: Positive direction: Forward rotation (CCW); Set 1: Positive direction: Reverse rotation (CW).
10	CONT1 signal distribution	1	CONT1 is distributed as RUN (i.e. SON); if not distributed, CONT1 will be auto ON if there is no alarming when powered.
11	CONT2 signal distribution	2	CONT2 is distributed as RST (i.e. servo alarming clearance CLR). When 12, 13, 14 are 0, that is CONT3, CONT4 and CONT5 can't be distributed as OT over-travel or EMG (external emergency stop).
15	OUT1 signal distribution	1	Set 1, OUT1 is distributed as a-contact point of alarming output; Set 2, OUT1 is distributed as b-contact point of alarming detection.
27	Parameter write-protection	0 or 1	Set 0, write-enable. Set 1, write-protected.

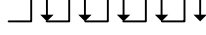

## 5.1.8 Parameter Setting of STONE GS Servo Driver

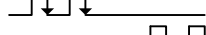
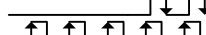
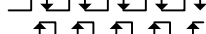
Para. No.	Para. Name	Value	Description																							
F0f	Electronic gear ratio numerator	2	Electronic gear ratio of position mode: $4 \times \text{pulse frequency fed back by motor encoder} = \text{command pulse frequency} \times F0f / F10$ ; value of $F0f / F10$ must be within $1/100 \sim 100$ . (calculation with pitch as 10mm)																							
F10	Electronic gear ratio denominator	1																								
F00	Control mode selection	2	<p>0: External speed running mode; make sure the value and direction of motor speed according to the external analog <math>-10V \sim +10V</math> signal of CN2-16, 17;</p> <p>1: Internal speed running mode; make sure the value and direction of motor speed according to the setting of parameter F33, F35, F37, F39 and the port status of CN2-9, CN2-25;</p> <p>2: Position pulse running mode; accept the input of external position pulse and direction level signal;</p> <p>3: Jog mode; make sure the motor speed in terms of parameter setting of F3b, and control the rotation direction by the direction keystroke ▼ and ▲;</p> <p>4: Torque mode; make sure the value and direction of motor torque according to the external analog <math>-10V \sim +10V</math> signal of CN2-43, 1;</p> <p>5~10: Mixed mode; select mode according to the port input status of CN2-24:</p> <table border="1" data-bbox="651 1294 1401 1608"> <thead> <tr> <th rowspan="2">F00 Value</th> <th colspan="2">CN2-24 Interface Status</th> </tr> <tr> <th>OFF (Mode One)</th> <th>ON (Mode Two)</th> </tr> </thead> <tbody> <tr> <td>5</td> <td>Position Pulse Mode</td> <td>External Speed Running Mode</td> </tr> <tr> <td>6</td> <td>Position Pulse Mode</td> <td>Internal Speed Running Mode</td> </tr> <tr> <td>7</td> <td>Position Pulse Mode</td> <td>Torque Mode</td> </tr> <tr> <td>8</td> <td>Internal Speed Running Mode</td> <td>External Speed Running Mode</td> </tr> <tr> <td>9</td> <td>Internal Speed Running Mode</td> <td>Torque Mode</td> </tr> <tr> <td>10</td> <td>External Speed Running Mode</td> <td>Torque Mode</td> </tr> </tbody> </table>	F00 Value	CN2-24 Interface Status		OFF (Mode One)	ON (Mode Two)	5	Position Pulse Mode	External Speed Running Mode	6	Position Pulse Mode	Internal Speed Running Mode	7	Position Pulse Mode	Torque Mode	8	Internal Speed Running Mode	External Speed Running Mode	9	Internal Speed Running Mode	Torque Mode	10	External Speed Running Mode	Torque Mode
F00 Value	CN2-24 Interface Status																									
	OFF (Mode One)	ON (Mode Two)																								
5	Position Pulse Mode	External Speed Running Mode																								
6	Position Pulse Mode	Internal Speed Running Mode																								
7	Position Pulse Mode	Torque Mode																								
8	Internal Speed Running Mode	External Speed Running Mode																								
9	Internal Speed Running Mode	Torque Mode																								
10	External Speed Running Mode	Torque Mode																								

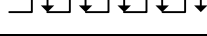
Para. No.	Para. Name	Value	Description	
<b>F2e</b>	Pulse input mode selection	2	Command pulse string mode selection of position mode:	
			1 - Single pulse train positive logic	Pulse <b>12</b> <b>27</b>  Direction <b>13</b> <b>28</b> 
			2 - Single pulse train negative logic	Pulse <b>12</b> <b>27</b>  Direction <b>13</b> <b>28</b> 
			3 - Double pulse train positive logic	CCW <b>12</b> <b>27</b>  CW <b>13</b> <b>28</b> 
			4 - Double pulse train negative logic	CCW <b>12</b> <b>27</b>  CW <b>13</b> <b>28</b> 
			5 - Orthogonal pulse positive logic	Phase A <b>12</b> <b>27</b>  Phase B <b>13</b> <b>28</b> 
6 - Orthogonal pulse negative logic	Phase A <b>12</b> <b>27</b>  Phase B <b>13</b> <b>28</b> 			

## 5.2 Driver Parameter Setting (Lambda 4S/5S/5E/5M)

### 5.2.1 Parameter Setting of WISE Servo Driver(Pulse)

Para. No.	Function	Value	Description
<b>Pr528</b>	LED initial status	6	Monitor if the number of sent and received pulses is correct by setting this parameter. In Weihong control system, the correct quantity of pulses sent by control card is detected by pulse inspection in order to determine whether there is electrical interference.
<b>Pr008</b>	Command pulse No. per motor circle	0	When it is set to "0", parameters Pr009 and Pr010 are valid.
<b>Pr009</b>	1st numerator of command pulse frequency division/multiplication	Need calculation	Range: 0~2 <sup>30</sup> Typical value: pitch 5 mm, encoder resolution 10000, deceleration ratio 1:1, pulse equivalent 0.001 mm/p:
<b>Pr010</b>	Denominator of command pulse frequency division/multiplication	Need calculation	Pr009=10000 Pr010=pitch/pulse equivalent=5000 Pr009/Pr010=10000/5000=2/1

Para. No.	Function	Value	Description
Pr011	Output pulse No. per motor circle	2500 (default)	Typical value: pulse equivalent 0.001mm/p, screw pitch 10mm without a reduction box, Pr011=2500; screw pitch 5mm, Pr011=1250.
Pr100	1st position loop gain	480 (default)	Unit: 0.1/s. Set it according to the actual situation.
Pr101	1st velocity loop gain	270 (default)	Unit: 0.1Hz. Set it according to the actual situation.
Pr102	1st velocity loop integrated time constant	210 (default)	Unit: 0.1ms. Set it according to the actual situation.
<p>When the value of Pr008 is not "0", it can be calculated in terms of the following formula:</p> $\text{Command pulse No. per motor circle} = \frac{\text{Screw pitch}}{\text{Pulse equivalent} \times \text{Mechanical deceleration ratio}} = \frac{5\text{mm}}{0.001\text{mm/p}} = 5000$ <p>When screw pitch is 5mm and pulse equivalent 0.001mm/p, the value of Pr008 is "5000".</p>			

◆ Attached list: the relationship among parameters Pr008, Pr009 and Pr010

Pr008	Pr009	Pr010	Description
1~2 <sup>20</sup>	— (no influence)	— (no influence)	<p>As shown above, the process is undergone in terms of the setting value of Pr008, not affected by the settings of Pr009 and Pr010.</p>
0	0	1~2 <sup>30</sup>	<p>When the values of Pr008 and Pr009 are both set to "0", as shown above, the process is undergone in terms of the setting value of Pr010.</p>
	1~2 <sup>30</sup>	1~2 <sup>30</sup>	<p>When the value of Pr008 is "0", but the value of Pr009 is not "0", as shown above, the process is undergone in terms of the setting values of Pr009 and Pr010.</p>

## 5.2.2 Parameter Setting of WISE Servo Driver(Bus)

Para. No.	Function	Value	Description
Pr001	Control mode setup	1	Control mode should be set up when bus function is used in WISE driver.
Pr528	LED initial status	6	Monitor if the number of sent and received pulses is correct by setting this parameter. In Weihong control system, the correct quantity of pulses sent by control card is detected by pulse inspection in order to determine whether there is electrical interference.
Pr008	Command pulse No. per motor circle	0	When it is set to "0", parameters Pr009 and Pr010 are valid.
Pr009	1st numerator of command pulse frequency division/multiplication	Need calculation	Range: $0 \sim 2^{30}$ Typical value: pitch 5 mm, encoder resolution 10000, deceleration ratio 1:1, pulse equivalent 0.001 mm/p: Pr009=10000 Pr010=pitch/pulse equivalent=5000 Pr009/Pr010=10000/5000=2/1
Pr010	Denominator of command pulse frequency division/multiplication	Need calculation	
Pr011	Output pulse No. per motor circle	2500 (default)	Typical value: pulse equivalent 0.001mm/p, screw pitch 10mm without a reduction box, Pr011=2500; screw pitch 5mm, Pr011=1250.
Pr100	1st gain of position loop	320 (default)	Unit: 0.1/s. Set it according to the actual situation.
Pr101	1st gain of velocity loop	180 (default)	Unit: 0.1Hz. Set it according to the actual situation.
Pr102	1st time constant of velocity loop integration	310 (default)	Unit: 0.1ms. Set it according to the actual situation.
Pr104	1st time constant of torque filter	126 (default)	Unit: 0.01ms. Set it according to the actual situation.
Pr110	Velocity feed forward gain	300 (default)	Unit: 0.1%. Set it according to the actual situation.
Pr111	Velocity feed forward filter	200 (default)	Unit: 0.01ms. Set it according to the actual situation.

Para. No.	Function	Value	Description
Pr207	3rd notch frequency	5000 (default)	Unit: Hz. Set it according to the actual situation.
Pr208	3rd notch width selection	2(default)	Set it according to the actual situation.
Pr209	3rd notch depth selection	0(default)	Set it according to the actual situation.
Pr210	4th notch frequency	5000 (default)	Unit: Hz. Set it according to the actual situation.
Pr211	4th notch width selection	2(default)	Set it according to the actual situation.
Pr212	4th notch depth selection	0(default)	Set it according to the actual situation.
<p>When the value of Pr008 is not "0", it can be calculated in terms of the following formula:</p> $\text{Command pulse No. per motor circle} = \frac{\text{Screw pitch}}{\text{Pulse equivalent} \times \text{Mechanical deceleration ratio}} = \frac{5\text{mm}}{0.001\text{mm}/p} = 5000$ <p>When screw pitch is 5mm and pulse equivalent 0.001mm/p, the value of Pr008 is "5000".</p>			

### 5.2.3 Parameter Setting of YASKAWA $\Sigma$ -II Servo Driver

Para. No.	Function	Value	Description
Fn010	Set password (to prevent arbitrary modification to parameters)	0000	Set [0000]: modification to user parameters [PnXXX] and part of auxiliary function parameters [FnXXX] permitted; Set [0001]: modification to user parameters [PnXXX] and part of auxiliary function parameters [FnXXX] prohibited.
Un00C	Surveillance mode	LXXXX (Hexa-decimal system)	Monitor if the number of sent and received pulses is correct by setting this parameter. In Weihong control system, the correct quantity of pulses sent by control card is detected by pulse inspection in order to determine whether there is electrical interference.
Pn000	Direction selection Control mode selection	0010	Bit 0: Set 0, "CCW" is forward rotation (viewed from the load end of screw ball); Set 1, the rotation direction of the motor is reversed. Bit 1: Set 1, position control mode (calculate pulse instruction all the time).
Pn200	Select pulse instruction mode	0005	Bit 0: Set 5, select the instruction input mode as "pulse + direction", negative logic.

Para. No.	Function	Value	Description
			Bit 3: Set 0, input differential signal into filter.
<b>Pn50A</b>	Selection function	8100	Bit 1: Set 0, Servo ON /S-ON, input from 40th pin; Set 7, Servo ON all the time. Bit 3: Set 8, positive rotation not used and signal input (P-OT) prohibited.
<b>Pn50B</b>	Selection function	6548	Bit 0: Set 8, reverse rotation not used and signal input (N-OT) prohibited.
<b>Pn50F</b>	Selection function	0300	Set it when servo motor with brakes. Bit 2: Set 3, brake interlock signal "/BK" is output from CN1-29, CN1-30 to control 24V relay for brake.
<b>Pn50E</b>	Selection function	0211	Set it when servo motor with brakes. To avoid of CN1-29 and CN1-30 being used for other function and leading to brake ineffective, "3" is not allowed to appear in the 4 digits.
<b>Pn506</b>	Servo off, time delay of brake when motor stops	Depended	Set it when motor with brakes. Default setting is "0", setting unit is 10ms.
<b>Pn201</b>	PG division ratio	Need Calculation	Range: $16 \sim 2^{14}$ , set according to the parameter setting of "Frequency Division Pulses of PG (X4)". Typical value: pulse equivalent 0.001mm/p, screw pitch 10mm without a reduction box, Pn201=2500; screw pitch 5mm, Pn201=1250.
<b>Pn202</b>	Electronic gear ratio (numerator)	Need Calculation	Pn202 = pulse No. of each encoder circle $\times 4 \times$ mechanical deceleration ratio. Pn203 = (screw pitch/ pulse equivalent).
<b>Pn203</b>	Electronic gear ratio (denominator)	Need Calculation	Typical value: pitch 5mm, encoder 17-bit, deceleration ratio 1:1, pulse equivalent 0.001mm/p, Pn202=16384; Pn203=625. Pitch 5mm, encoder 17-bit, deceleration ratio 1:1, pulse equivalent 0.0005mm/p, Pn202=8192; Pn203=625.

## 5.2.4 Parameter Setting of YASKAWA $\Sigma$ -V / $\Sigma$ -7 Servo Driver

Para. No.	Function	Value	Description
<b>Fn010</b>	Parameter input prohibition setting	0000	Set [0000]: modification to user parameters [PnXXX] and part of auxiliary function parameters [FnXXX] permitted; Set [0001]: Modification to user parameters [PnXXX] and part of auxiliary function parameters [FnXXX] prohibited.
<b>Pn000</b>	Function selection basic switch 0	0010	Bit 0: Set 0, positive rotation at positive rotation command. Bit 1: Set 1, position control mode (pulse sequence command).
<b>Pn200</b>	Format selection switch of position control command	0005	Bit 0: Set 5, select the instruction mode as “pulse + direction”, negative logic.
<b>Pn50A</b>	Input signal selection 1	8100	Bit 1: Set 0, Servo ON /S-ON, input from the 40th pin; Set 7, Servo ON all the time. Bit 3: Set 8, positive rotation not used and signal input (P-OT) prohibited.
<b>Pn50B</b>	Input signal selection 2	6548	Bit 0: Set 8, negative rotation not used and signal input (N-OT) prohibited.
<b>Pn50F</b>	Output signal selection 2	0300	Set it when servo motor with brakes. Bit 2: Set 3, brake interlock signal “/BK” is output from CN1-29, CN1-30 to control 24V relay used for brake.
<b>Pn50E</b>	Output signal selection 1	0211	Set it when servo motor with brakes To avoid of CN1-29 and CN1-30 being used for other function and leading to brake ineffective, 3 is not allowed to appear in the 4 digits.
<b>Pn506</b>	Brake instruction- servo OFF and time delay	Depended	Set it when motor with brakes. Default setting is “0”, setting unit is ms.

Para. No.	Function	Value	Description
<b>Pn20E</b>	Electronic gear ratio (numerator)	Need Calculation	$\frac{Pn20E}{Pn210} = \frac{\text{Encoder resolution} \times \text{Pulse equivalent} \times \text{Deceleration ratio}}{\text{Screw pitch}}$ <p>For example, screw pitch 5mm, 20-bit encoder, deceleration ratio 1:1, pulse equivalent 0.001mm/p,</p>
<b>Pn210</b>	Electronic gear ratio (denominator)	Need Calculation	$\frac{Pn20E}{Pn210} = \frac{2^{20} \times 0.001}{5} = \frac{1048576}{5000} = \frac{131072}{625}$ <p>When screw pitch is 10mm, <math>\frac{Pn20E}{Pn210} = \frac{1048576}{10000} = \frac{65536}{625}</math></p> <p>For a rotary axis with 13-bit encoder and deceleration ratio as 60,</p> $\frac{Pn20E}{Pn210} = \frac{2^{13} \times 0.001 \times 60}{360} = \frac{8192}{6000} = \frac{512}{375}$
<b>Pn212</b>	Encoder output pulses	Need Calculation	<p>Range: 16~2<sup>30</sup>, set according to the parameter setting of "Frequency Division Pulses of PG (X4)".</p> <p>Typical value: pulse equivalent 0.001mm/p, screw pitch 10mm without a reduction box, Pn212=2500; screw pitch 5mm, Pn212=1250.</p>



## 5.2.5 Parameter Setting of YASKAWA $\Sigma$ -7 Servo Driver(Bus)

Para. No.	Function	Value	Description
Pn000	Function selection switch 0 basic	0000	<p>Bit 0 (Rotation direction selection)</p> <p>0: use CCW as the forward direction. Use the direction in which the linear encoder counts up as the forward direction.</p> <p>1: use CW as the forward direction. (Reverse Rotation Mode) Use the direction in which the linear encoder counts down as the forward direction. (Reverse Movement Mode)</p> <p>Bit 1 and 2: reserved parameter (Do not change.)</p> <p>Bit 3 (Rotary/linear servomotor startup selection when encoder is not connected)</p> <p>0: When an encoder is not connected, start as SERVOPACK for Rotary Servomotor.</p> <p>1: When an encoder is not connected, start as SERVOPACK for Linear Servomotor.</p>
Pn002	Function selection switch 2 basic	0000	<p>Bit 0 (Speed/position control option)</p> <p>0: Do not use T-REF.</p> <p>1: Use T-REF as an external torque limit input.</p> <p>2: Use T-REF as a torque feedback input.</p> <p>3: Use T-REF as an external torque limit input when /P-CL or /N-CL is ON.</p> <p>Bit 1 (Torque control option)</p> <p>0: Do not use V-REF.</p> <p>1: Use V-REF as an external speed limit input.</p> <p>Bit 2 (Encoder usage)</p> <p>0: Use the encoder according to encoder specifications.</p> <p>1: Use the encoder as an incremental encoder.</p> <p>2: Use the encoder as a single-turn absolute encoder. (Rotary motor)</p> <p>Bit 3 (External encoder usage )</p> <p>0: Do not use an external encoder;</p> <p>1: Use the encoder as an incremental encoder;</p> <p>2: Reserved setting (Do not use.)</p> <p>3: The external encoder moves in the reverse direction</p>

Para. No.	Function	Value	Description
			for CCW motor rotation; 4: Reserved setting (Do not use.).
<b>Pn008</b>	Function selection switch 8 basic	4000	Bit 0 (Low battery voltage alarm/warning selection) 0: Output alarm (A.830) for low battery voltage. 1: Output warning (A.930) for low battery voltage. Bit 1 (Function selection for undervoltage) 0: Do not detect undervoltage. 1: Detect undervoltage warning and limit torque at host controller. 2: Detect undervoltage warning and limit torque with Pn424 and Pn425 (i.e., only in SERVOPACK). Bit 2 (Warning detection selection) 0: Detect warnings. 1: Do not detect warnings except for A.971. Bit 3: reserved parameter (Do not change.)
<b>Pn00B</b>	Function selection switch B basic	0000	Bit 0 (Operator parameter display selection) 0: Display only setup parameters. 1: Display all parameters. Bit 1 (Motor stopping method for group 2 alarms) 0: Stop the motor by setting the speed reference to 0. 1: Apply the dynamic brake or coast the motor to a stop (use the stopping method set in Pn001 = n. □□□X). 2: Set the stopping method with Pn00A = n. □□□X. Bit 2 (Power input selection for three-phase servopack) 0: Use a three-phase power supply input. 1: Use a three-phase power supply input as a single-phase power supply input. Bit 3: reserved parameter (Do not change.)
<b>Fn010</b>	Parameter input prohibition setting	0000	Set [0000]: modification to user parameters [PnXXX] and part of auxiliary function parameters [FnXXX] permitted; Set [0001]: Modification to user parameters [PnXXX] and part of auxiliary function parameters [FnXXX] prohibited.
<b>Pn100</b>	Speed loop gain	400	10~20000. Unit: Hz.

Para. No.	Function	Value	Description
<b>Pn101</b>	Speed loop integral time constant	2000	15~51200. Unit: ms.
<b>Pn102</b>	Position loop gain	400	10~20000.
<b>Pn103</b>	Moment of inertia ratio	100	0~20000.
<b>Pn109</b>	Feedforward	0	0~100.
<b>Pn10A</b>	Feedforward filter time constant	0	0~64. Unit: ms.
<b>Pn11F</b>	Position integral time constant	0	0~50000. Unit: ms.
<b>Pn140</b>	Model following control-related selections	0100	<p>Bit 0 (Model following control selection) 0: Do not use model following control. 1: Use model following control.</p> <p>Bit 1 (Vibration suppression selection) 0: do not perform vibration suppression. 1: Perform vibration suppression for a specific frequency. 2: Perform vibration suppression for two specific frequencies.</p> <p>Bit 2 (Vibration suppression adjustment selection) 0: Do not adjust vibration suppression automatically during execution of autotuning without a host reference, autotuning with a host reference, and custom tuning. 1: Adjust vibration suppression automatically during execution of autotuning without a host reference, autotuning with a host reference, and custom tuning.</p> <p>Bit 3 (Speed feedforward (vff)/torque feedforward (tff) selection) 0: Do not use model following control and speed/torque feedforward together. 1: Use model following control and speed/torque feedforward together.</p>
<b>Pn160</b>	Anti-resonance control selections	0010	<p>Bit 0 (Anti-resonance control selection) 0: Do not use anti-resonance control. 1: Use anti-resonance control.</p>

Para. No.	Function	Value	Description
			Bit 1 (Anti-resonance control adjustment selection) 0: Do not adjust anti-resonance control automatically during execution of autotuning without a host reference, autotuning with a host reference, and custom tuning. 1: Adjust anti-resonance control automatically during execution of autotuning without a host reference, autotuning with a host reference, and custom tuning. Bit 1 and 2: reserved parameter (do not change.)
<b>Pn170</b>	Tuning-less function-related selections	1401	Bit 0 (Tuning-less selection) 0: Disable tuning-less function. 1: Enable tuning-less function. Bit 1 (Speed control method) 0: Use for speed control. 1: Use for speed control and use host controller for position control. Bit 2 (Rigidity level) 0~7: Set the rigidity level. Bit 3 (Tuning-less load level) 0 ~ 2: Set the load level for the tuning-less function.
<b>Pn20E</b>	Electronic gear ratio (numerator)	1	$\frac{Pn20E}{Pn210} = \frac{\text{Encoder resolution} \times \text{Pulse equivalent} \times \text{Deceleration ratio}}{\text{Screw pitch}}$ For example, screw pitch 5mm, 20-bit encoder, deceleration ratio 1:1, pulse equivalent 0.001mm/p,
<b>Pn210</b>	Electronic gear ratio (denominator)	1	$\frac{Pn20E}{Pn210} = \frac{2^{20} \times 0.001}{5} = \frac{1048576}{5000} = \frac{131072}{625}$ When screw pitch is 10mm, $\frac{Pn20E}{Pn210} = \frac{1048576}{10000} = \frac{65536}{625}$ For a rotary axis with 13-bit encoder and deceleration ratio as 60, $\frac{Pn20E}{Pn210} = \frac{2^{13} \times 0.001 \times 60}{360} = \frac{8192}{6000} = \frac{512}{375}$
<b>Pn212</b>	Number of encoder output pulses	2048	Range: 16~2 <sup>30</sup> , set according to the parameter setting of "Frequency Division Pulses of PG (X4)". Typical value: pulse equivalent 0.001mm/p, screw pitch 10mm without a reduction box, Pn212=2500; screw pitch 5mm, Pn212=1250.
<b>Pn401</b>	First stage first torque reference filter time	100	0~65535. Unit: ms.

Para. No.	Function	Value	Description
	constant		
<b>Pn408</b>	Torque-related function selections	0000	<p>Bit 0 (Notch filter selection 1) 0: Disable first stage notch filter. 1: Enable first stage notch filter.</p> <p>Bit 1 (Speed limit selection) 0: Use the smaller of the maximum motor speed and the setting of Pn407 as the speed limit. Or use the smaller of the maximum motor speed and the setting of Pn480 as the speed limit. 1: Use the smaller of the overspeed alarm detection speed and the setting of Pn407 as the speed limit. Or use the smaller of the overspeed alarm detection speed and the setting of Pn480 as the speed limit.</p> <p>Bit 2 (Notch filter selection 2) 0: Disable second stage notch filter. 1: Enable second stage notch filter.</p> <p>Bit 3 (Friction compensation function selection) 0: Disable friction compensation. 1: Enable friction compensation.</p>
<b>Pn409</b>	First stage notch filter frequency	5000	50~5000. Unit: Hz.
<b>Pn40C</b>	Second stage notch filter frequency	5000	50~5000. Unit: Hz.
<b>Pn460</b>	Notch filter adjustment selections 1	0101	<p>Bit 0 (Notch filter adjustment selection 1) 0: Do not adjust the first stage notch filter automatically during execution of autotuning without a host reference, autotuning with a host reference, and custom tuning. 1: Adjust the first stage notch filter automatically during execution of autotuning without a host reference, autotuning with a host reference, and custom tuning.</p> <p>Bit 1: reserved parameter (Do not change.)</p> <p>Bit 2 (Notch filter adjustment selection 2) 0: Do not adjust the second stage notch filter automatically during execution of autotuning without a host reference, autotuning with a host reference, and custom tuning. 1: Adjust the second stage notch filter automatically</p>

Para. No.	Function	Value	Description
			during execution of autotuning without a host reference, autotuning with a host reference, and custom tuning. Bit 3: reserved parameter (do not change.)
<b>Pn503</b>	Speed coincidence detection signal output width	10	0~100. Unit: min <sup>-1</sup> .
<b>Pn506</b>	Brake reference servo OFF delay time	0	Set it according to the actual situation. Unit: ms.
<b>Pn509</b>	Momentary power interruption hold time	20	20~5000. Unit: ms.
<b>Pn50A</b>	Input signal selection 1	1881	Bit 1: Set 0, Servo ON /S-ON, input from the 40th pin; Set 7, Servo ON all the time. Bit 3: Set 8, positive rotation not used and signal input (P-OT) prohibited.
<b>Pn50B</b>	Input signal selection 2	6548	Bit 0: Set 8, negative rotation not used and signal input (N-OT) prohibited.
<b>Pn50E</b>	Output signal selection 1	0000	Set it when servo motor with brakes To avoid of CN1-29 and CN1-30 being used for other function and leading to brake ineffective, 3 is not allowed to appear in the 4 digits.
<b>Pn50F</b>	Output signal selection 2	0100	Set it when servo motor with brakes. Bit 2: Set 3, brake interlock signal "/BK" is output from CN1-29, CN1-30 to control 24V relay used for brake.
<b>Pn510</b>	Output signal selection 3	0000	Bit 0 (/NEAR (near output) signal allocation) 0: Disabled (the above signal output is not used). 1: Output the signal from the CN1-1 or CN1-2 output terminal. 2: Output the signal from the CN1-23 or CN1-24 output terminal. 3: Output the signal from the CN1-25 or CN1-26 output terminal. Bit 1/2/3: reserved parameter (Do not change.)

Para. No.	Function	Value	Description
<b>Pn514</b>	Output signal selection 4	0000	Bit 0/1/3: Reserved parameter (Do not change.) Bit 2: /PM (Preventative Maintenance Output) Signal Allocation 0: Disabled (the above signal output is not used). 1: Output the signal from the CN1-1 or CN1-2 output terminal. 2: Output the signal from the CN1-23 or CN1-24 output terminal. 3: Output the signal from the CN1-25 or CN1-26 output terminal.
<b>Pn520</b>	Position deviation overflow alarm level	5242880	Set value: 5242880.
<b>Pn522</b>	Positioning completed width	7	Set value: 200.
<b>Pn600</b>	Regenerative resistor capacity	0	Depends on model. Unit: W.

## 5.2.6 Parameter Setting of Panasonic MINAS A4 Servo Driver

Para. No.	Function	Value	Description
<b>Pr01</b>	LED initial status	12	Monitor if the number of sent and received pulses is correct by setting this parameter. In Weihong control system, the correct quantity of pulses sent by control card is detected by pulse inspection in order to determine whether there is electrical interference.
<b>Pr02</b>	Select control mode	0	0: position mode 1: velocity mode 2: torque mode
<b>Pr40</b>	Selection of command pulse input	1	1: input by differential exclusive circuit
<b>Pr42</b>	Select command pulse input mode	3	Set command pulse input mode: command pulse + command direction, negative logic
<b>Pr44</b>	Numerator of pulse output	Need calculation	Range: 1~32767, set according to the parameter setting of "Frequency Division

	division/multiplication		Pulses of PG (X4)". Typical value: pulse equivalent 0.001mm/p, screw pitch 10mm without a reduction box, Pr44 =2500; screw pitch 5mm, Pr44=1250.
<b>Pr48</b>	1st numerator of command pulse frequency multiplication	Need calculation Range: 1~10000	Typical value: pitch 5 mm, encoder resolution 10000, deceleration 1:1, pulse equivalent 0.001mm/p: Pr48= 10000
<b>Pr4B</b>	Denominator of command pulse frequency multiplication	Need calculation Range: 1~10000	Pr4B=pitch/pulse equivalent=5000 Pr48/Pr4B=10000/5000=2/1



## 5.2.7 Parameter Setting of Panasonic MINAS A5 Servo Driver

Para. No.	Function	Value	Description
Pr5.28	LED initial status	6	Monitor if the number of sent and received pulses is correct by setting this parameter. In Weihong control system, the correct quantity of pulses sent by control card is detected by pulse inspection in order to determine whether there is electrical interference.
Pr0.01	Select control mode	0	0: position mode 1: velocity mode 2: torque mode
Pr0.05	Selection of command pulse input	XX	0: Photo-coupler input (PULS1, PULS2, SIGN1, SIGN2) 1: Exclusive input for line driver (PULSH1, PULSH2, SIGNH1, SIGNH2) Note: generally, "1" is selected for this parameter.
Pr0.07	Command pulse input mode setup	3	Set command pulse input mode: command pulse + command direction, negative logic.
Pr0.08	Command pulse No. per motor circle	0	When it is set as "0", parameters Pr0.09 and Pr0.10 are valid.
Pr0.09	1st numerator of command pulse frequency multiplication	Need calculation Range: 0~2 <sup>30</sup>	Typical value: pitch 5 mm, encoder resolution 10000, deceleration ratio 1:1, pulse equivalent 0.001 mm/p: Pr0.09=10000 Pr0.10=pitch/ pulse equivalent=5000 Pr0.09/Pr0.10=10000/5000=2/1
Pr0.10	Denominator of command pulse frequency multiplication	Need calculation Range: 0~2 <sup>30</sup>	
Pr0.11	Output pulse No. per motor circle	2500	Range: 1~262144, set according to the parameter setting of "Frequency Division Pulses of PG (X4)". Typical value: pulse equivalent 0.001mm/p, screw pitch 10mm without a reduction box, Pr0.11=2500; screw pitch 5mm, Pr0.11=1250.
<p>When the value of Pr0.08 is not "0", it can be calculated in terms of the following formula:</p> $\text{Command pulse No. per motor circle} = \frac{\text{Screw pitch}}{\text{Pulse equivalent} \times \text{Mechanical deceleration ratio}} = \frac{5\text{mm}}{0.001\text{mm/p}} = 5000$ <p>When screw pitch is 5mm and pulse equivalent 0.001mm/p, the value of Pr0.08 is "5000".</p>			

◆ Attached List: relationship among parameters Pr0.08, Pr0.09 and Pr0.10

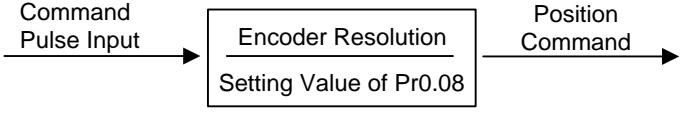
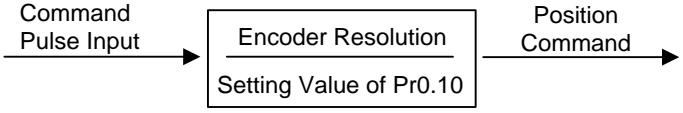
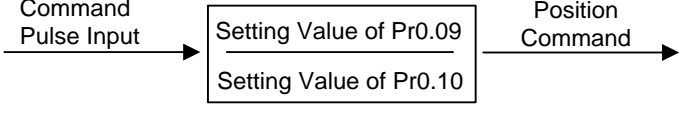
Pr0.08	Pr0.09	Pr0.10	Description
1~2 <sup>20</sup>	— (no influence)	— (no influence)	 <p>As shown above, the process is undergone in terms of the setting value of Pr0.08, not affected by the settings of Pr0.09 and Pr0.10.</p>
0	0	1~2 <sup>30</sup>	 <p>When the values of Pr0.08 and Pr0.09 are both set as “0”, as shown above, the process is undergone in terms of the setting value of Pr0.10.</p>
	1~2 <sup>30</sup>	1~2 <sup>30</sup>	 <p>When the value of Pr0.08 is “0”, but the value of Pr0.09 is not “0”, as shown above, the process is undergone in terms of the setting values of Pr0.09 and Pr0.10.</p>

## 5.2.8 Parameter Setting of MITSUBISHI MR-JE Servo Driver

Para. No.	Code	Function	Value	description
PA01	*STY	Operation mode	XXX0	__ _x: select position control mode.
PD24	MBR	Output assignation to CN1-23 pin	XX05	_ _ xx: select MBR (electromagnetic brake interlock).
PA06	CMX	Electronic gear numerator	Need calculation	CMX/CDV=command unit × servo motor resolution × mechanical deceleration ratio / pitch of screw. E.G., pitch 5 mm, encoder resolution 10000, deceleration ratio 1:1, pulse equivalent 0.001 mm, CMX/CDV=10000×0.001/5 = 2/1; When pulse equivalent = 0.0005mm/p, CMX/CDV = 1/1. Electronic gear ratio range: 1/50 ~ 500
PA07	CDV	Electronic gear denominator	Need calculation	
PC36	*DMD	Status display selection	00XX	__xx: status display selection at power-on. This is used to select a status display shown at power-on. 00: cumulative feedback pulses 01: servo motor speed 02: droop pulses 03: cumulative command pulses 04: command pulse frequency
PA13	*PLSS	Command pulse input form	0011	Set command pulse input form: pulse train+ sign, negative logic.
PA15	*ENR	Encoder output pulses	Need calculation	Range: 1~65535, set according to the parameter setting of "Frequency Division Pulses of PG (X4)". Typical value: pulse equivalent 0.001mm/p, screw pitch 10mm without a reduction box, PA15=2500; screw pitch 5mm, PA15=1250.
PD03	*DI1L	Input assignation to CN1-15 pin	XX02	_ _xx: select SON under position control mode.

## 5.2.9 Parameter Setting of MITSUBISHI MR-E Servo Driver

Para. No.	Code	Function	Value	Description
0	*STY	Select control mode and regenerative fittings	X0X0	Bit 0: set 0: select position control mode. Bit 1, select motor series: 0: HC-KFE; 1:HC-SFE; Bit 3, select regenerative apparatus, set 0: not use. Bit 4, select motor power.
1	MBR	Function selection 1	001X	Bit 0: input signal filter. If external input signal causes chattering due to noises, etc., input filter is used to suppress it. Bit 1: CN1-12 function selection, set "1": electromagnetic brake interlock (MBR); set "0": zero speed detection signal.
3	CMX	Electronic gear numerator	Need calculation	CMX/CDV=command unit × servo motor resolution × mechanical deceleration ratio / screw pitch. E.G., pitch 5 mm, encoder resolution 10000, deceleration ratio 1:1, pulse equivalent 0.001 mm/p, CMX/CDV=10000×0.001/5 = 2/1; When pulse equivalent = 0.0005mm/p, CMX/CDV = 1/1. Electronic gear ratio range: 1/50 ~ 500.
4	CDV	Electronic gear denominator	Need calculation	
18	*DMD	Status display selection	00XX	3: cumulative command pulses E: load inertia When the parameter is set [3], monitor if the number of sent and received pulses is correct by setting this parameter. In Weihong control system, the correct quantity of pulses sent by control card is detected by pulse inspection to determine if there is electrical interference.
21	*OP3	Function selection 3 (command pulse format selection)	0001	Set pulse command input form: pulse train+ sign, negative logic
27	*ENR	Encoder output pulses	Need calculation	Range: 1~65535, set according to the parameter setting of "Frequency Division Pulses of PG (X4)". Typical value: pulse equivalent 0.001mm/p, screw pitch 10mm without a reduction box, the value is 2500; screw pitch 5mm, the value is 1250.

Para. No.	Code	Function	Value	Description
41	*DIA	Signal input SON-ON, LSP-ON and LSN-ON automatically selection	0110	Bit 0: Servo-ON selection. [0]: servo on by external input; [1]: servo on all the time inside. Bit 1: last signal of positive rotation range (LSP), [1]: auto servo on inside, without external wiring. Bit 3: last signal of negative rotation range (LSN): [1]: auto servo on inside and no need of external wiring.



- 1) Both positional control mode and velocity control mode are supported for MR-E-A series servo drivers
- 2) Only velocity control mode (analog input) is supported for MR-E-AG series servo drivers.

### 5.2.10 Parameter Setting of DELTA ASDA-A Servo Driver

Para. No.	Function	Format & Range	Value	Description
P0-02	Driver display status		02	Monitor if the number of sent and received pulses is correct by setting this parameter. In Weihong control system, the correct quantity of pulses sent by control card is detected by pulse inspection to determine if there is electrical interference.
P1-00	External pulse input type	ZYX	102	X=2: pulse + direction; Z=1: negative logic
P1-01	Control mode setup	ZYX1X0	0000	Z=0: during control mode switching, DIO is maintaining the set value. Since switching control mode is not used, Z=0 Y=0: forward rotation (CCW) (in terms of load); Y=1: the rotation direction is reversed. X1X0=00: position control mode.
P1-32	Motor stop mode selection	YX	00	Y=0: when there is no servo enabled, motor dynamic brake occurs; Y=1: motor is free. X=0: motor stops instantly, X=1: motor stops with deceleration.

Para. No.	Function	Format & Range	Value	Description
P1-44	Electronic Gear Ratio (Numerator)(N1)	1~32767	Need calculation	N1/M= encoder pulses× 4× pulse equivalent× mechanical deceleration ratio/pitch Representative value: encoder pulses=2500, pitch=5mm, pulse equivalent=0.001mm/p, deceleration ratio=1, calculation as below: N1/M= 2500×4×0.001/5 = 2 / 1, N1=2, M=1; When the multi-electronic gear ratio is not used, P2-60~ P2-62 are not required.
P1-45	Electronic Gear Ratio (Denominator) (M)	1~32767	Need calculation	
P2-10	Digital input pin DI1	X2X1X0	101	X1X0=01: digital input (DI1=SON) corresponds to 9th pin of CN1. X2 = 1: set DI1 input as NO (normally open) a-contact point.
P2-15	Digital input pin DI6	X2X1X0	100	Default factory setting of DI6 and DI7 are NC (normally closed) limit signal input pins; driver can't run without being connected to pin 32 and pin 31 of CN1. X2=1: set DI6 and DI7 inputs as NO (normally open) a-contact points; X1X0=00, limit signal input of the driver is not used.
P2-16	Digital input pin DI7	X2X1X0	100	
P2-17	Function setting for digital input pin DI8	X2X1X0	100	External EMG stop input is not used.
P2-21	Function setting for digital output pin DO4	X2X1X0	108	DO4 corresponds to pin 1 & pin 26, used as clamping-position brake signal of Z-axis; X2=1: set DO4 output as NO (normally open) a-contact point; X2=0: set DO4 output as NC (normally closed) b-contact point; X1X0=08: set pin 1 and pin 26 as BK+ and BK- respectively.
P2-22	Function setting for digital output pin DO5	X2X1X0	007	DO5 corresponds to pin 28 & pin 27, used as servo alarm signal. X2=0: set DO5 output as NC (normally closed) b-contact point. X1X0=07: set pin 28 and pin 27 as ALRM+ and ALRM- respectively.

Para. No.	Function	Format & Range	Value	Description
P2-51	Servo ON (SON) setup		0	0: Servo ON must be triggered by numerical input signal. 1: when servo is powered, if there is no alarm signal, servo will be automatically on. Set 1 when there is no SON signal wire.

### 5.2.11 Parameter Setting of DELTA ASDA-A2 Servo Driver

Para. No.	Function	Format & Range	Value	Description
P0-02	Driver status display		02	Monitor if the number of sent and received pulses is correct by setting this parameter. In Weihong control system, the correct quantity of pulses sent by control card is detected by pulse inspection in order to determine whether there is electrical interference.
P1-00	External pulse train input type	ZYX	102	X=2: pulse + direction; Z=1: negative logic
P1-01	Set control mode	ZYX1X0	0000	Z=0: during control mode switching, DIO is maintaining the set value. Since switching control mode is not used, Z=0; Y=0: forward rotation (CCW) (from the view of load); Y=1: the rotation direction is reversed. X1X0=00: position control mode
P1-44	Electronic Gear Ratio (Numerator) (N1)	1~32767	Need calculation	$\frac{P1-44}{P1-45} = \frac{\text{Encoder resolution} \times \text{Pulse equivalent} \times \text{Deceleration ratio}}{\text{Screw pitch}}$ When encoder resolution is 1280000, screw pitch 5mm, pulse equivalent 0.001mm/p, and deceleration ratio 1:1, $\frac{P1-44}{P1-45} = \frac{1280000 \times 0.001}{5} = \frac{256}{1}$ When the multi-electronic gear ratio is not used, P2-60 ~P2-62 are not required.
P1-45	Electronic Gear Ratio (Denominator) (M)	1~32767	Need calculation	
P1-46	Encoder output pulse number	20~320000	Need calculation	Set according to the parameter setting of "Frequency Division Pulses of PG (X4)". Typical value: pulse equivalent 0.001mm/p, screw pitch 10mm without a reduction box, P1-46=10000; screw pitch 5mm, P1-46=5000.
P2-10	Function setting for digital input pin DI1	X2X1X0	101	X1X0=01: digital input (DI1 = SON) corresponds to 9th pin of CN1. X2=1: set DI1 input as NO (normally open) a-contact point.



Para. No.	Function	Format & Range	Value	Description
<b>P2-15</b>	Function setting for digital input pin DI6	X2X1X0	100	Default factory setting of DI6 and DI7 is NC (normally closed) limit signal input; driver can't run without being connected to pin 32 and pin 31 of CN1.
<b>P2-16</b>	Function setting for digital input pin DI7	X2X1X0	100	X2=1: set DI6 and DI7 inputs as NO a-contact point. X1X0=00, limit input of driver is not used.
<b>P2-17</b>	Function setting for digital input pin DI8	X2X1X0	100	External EMG stop input is not used.
<b>P2-21</b>	Function setting for digital output pin DO4	X2X1X0	108	DO4 corresponds to pin 1 & pin 26, used as clamping-position brake signal of Z-axis; X2=1: set DO4 output as NO (normally open) a-contact point; X2=0: set DO4 output as NC (normally closed) b-contact point; X1X0=08: set pin 1 and pin 26 as BK+ and BK- respectively.
<b>P2-22</b>	Function setting for digital output pin DO5	X2X1X0	007	DO5 corresponds to pin 28 & pin 27, used as servo alarm signal. X2=0: set DO5 output as NC b-contact point. X1X0=07: set pin 28 and pin 27 as ALRM+ and ALRM- respectively.

## 5.2.12 Parameter Setting of DELTA ASDA-B Servo Driver

Para. No.	Function	Format & Range	Value	Description
P0-02	Driver status display		02	Monitor if the number of sent and received pulses is correct by setting this parameter. In Weihong control system, the correct quantity of pulses sent by control card is detected by pulse inspection in order to determine whether there is electrical interference.
P1-00	External pulse train input type	ZYX	102	X=2: pulse + direction; Z=1: negative logic
P1-01	Set control mode	YX1X0	000	Y=0: forward rotation (CCW) (from the view of load); Y=1: the rotation direction is reversed. X1X0=00: position control mode
P1-32	Motor stop mode	YX	00	Y=0: when there is no servo enabled, motor dynamic brake occurs; Y=1: motor is free. X=0: motor stops instantly, X=1: motor stops with deceleration.
P1-44	Electronic Gear Ratio (Numerator)(N1)	1~32767	Need calculation	N1/M= mechanical deceleration ratio $\times$ 4 $\times$ encoder pulses $\times$ pulse equivalent / pitch. Representative value: encoder pulses=2500, pitch =5mm, pulse equivalent=0.001 mm/p, deceleration ratio = 1, calculation as below: $N1 / M = 2500 \times 4 \times 0.001 / 5 = 2 / 1$ , N1=2, M=1; When the multi-electronic gear ratio is not used, P2-60 ~P2-62 are not required.
P1-45	Electronic Gear Ratio (Denominator)(M)	1~32767	Need calculation	
P2-10	Function setting for digital input pin 1 (DI1)	X2X1X0	101	X1X0=01: digital input (DI1 = SON) corresponds to 17th pin of CN1. X2=1: set DI1 input as NO (normally open) a-contact point.

Para. No.	Function	Format & Range	Value	Description
<b>P2-15</b>	Function setting for digital input pin DI6	X2X1X0	100	Default factory setting of DI6 is NC (normally closed) limit signal input; driver can't run without being connected to pin 32 and pin 31 of CN1. X2=1: set DI6 input as NO a-contact point. X1X0=00, limit input of the driver is not used.
<b>P2-18</b>	Function setting for digital output pin DO1	X2X1X0	108	DO1 corresponds to 16th pin, as clamping-position brake signal of Z-axis; X2=1: set DO1 output as NO a-contact point; X2=0: set DO1 output as NC b-contact point; X1X0=08: set 16th pin as BK+.
<b>P2-20</b>	Function setting for digital output pin DO3	X2X1X0	007	DO3 corresponds to pin 1, used as servo alarm signal. X2=0: set DO3 output as NC b-contact point. X1X0=07: set pin 1 as ALRM+.

### 5.2.13 Parameter Setting of DELTA ASDA-B2 Servo Driver

Para. No.	Function	Format & Range	Value	Description
<b>P0-02</b>	Driver status display		02	Monitor if the number of sent and received pulses is correct by setting this parameter. In Weihong control system, the correct quantity of pulses sent by control card is detected by pulse inspection in order to determine whether there is electrical interference.
<b>P1-00</b>	External pulse train input type	ZYX	102	X=2: pulse + direction; Z=1: negative logic
<b>P1-01</b>	Set control mode	ZYX1X0	0000	Z=0: during control mode switching, DIO is maintaining the set value. Since switching control mode is not used, Z=0; Y=0: forward rotation (CCW) (from the view of load); Y=1: the rotation direction is reversed. X1X0=00: position control mode
<b>P1-44</b>	Electronic Gear Ratio (Numerator) (N1)	1~32767	Need calculation	N1/M= mechanical deceleration ratio × 4 × encoder pulses × pulse equivalent / pitch. Representative value: encoder pulses=40000, pitch =5mm, pulse equivalent=0.001mm/p, deceleration ratio = 1, calculation as below:
<b>P1-45</b>	Electronic Gear Ratio (Denominator) (M)	1~32767	Need calculation	N1 / M = 40000×4×0.001/5 = 32/1, N1=32, M=1; When the multi-electronic gear ratio is not used, P2-60 ~P2-62 are not required.
<b>P1-46</b>	Encoder output pulse number	20~40000	Need calculation	Set according to the parameter setting of "Frequency Division Pulses of PG (X4)". Typical value: pulse equivalent 0.001mm/p, screw pitch 10mm without a reduction box, P1-46=10000; screw pitch 5mm, P1-46=5000.
<b>P2-10</b>	Digital Input Pin DI1	X2X1X0	101	X1X0=01: digital input (DI1 = SON) corresponds to 9th pin of CN1. X2=1: set DI1 input as NO (normally open) a-contact point.

Para. No.	Function	Format & Range	Value	Description
<b>P2-15</b>	Function setting for digital input pin DI6	X2X1X0	000	Default factory setting of DI6 and DI7 is NC (normally closed) limit signal input; driver can't run without being connected to pin 32 and pin 31 of CN1.
<b>P2-16</b>	Function setting for digital input pin DI7	X2X1X0	000	X2=0: set DI6 and DI7 inputs as NC b-contact point. X1X0=00, limit input of driver is not used.
<b>P2-17</b>	Function setting for digital input pin DI8	X2X1X0	000	External EMG stop input is not used.
<b>P2-18</b>	Function setting for digital output pin DO1	X2X1X0	108	DO1 corresponds to pin 6 & pin 7, used as clamping-position brake signal of Z-axis; X2=1: set DO1 output as NO (normally open) a-contact point; X2=0: set DO1 output as NC (normally closed) b-contact point; X1X0=08: set pin 6 and pin 7 as BK- and BK+ respectively.
<b>P2-22</b>	Function setting for digital output pin DO5	X2X1X0	007	DO5 corresponds to pin 28 & pin 27, used as servo alarm signal. X2=0: set DO5 output as NC b-contact point. X1X0=07: set pin 28 and pin 27 as ALRM+ and ALRM- respectively.

## 5.2.14 Parameter Setting of SANYO PY Servo Driver

Para. No.	Abbr.	Name	Standard Value	Setting Range	Unit	Remark
1-2	EGER	Electronic gear ratio	4/1	1/32767 to 32767/1		<p>Depend on the specific encoder resolution. The formula of electronic gear ratio of servo driver is as below:</p> <p>Electronic gear ratio numerator = mechanical deceleration ratio × 4 × pulse No. per encoder circle;</p> <p>Electronic gear ratio denominator = (screw pitch / pulse equivalent)</p> <p>E.G. In Weihong system, the default pulse equivalent is 0.001mm/p, screw pitch is 5mm, pulse number per encoder circle is 2000 and deceleration ratio is 1:1; so the numerator of the electronic gear ratio is 8, and the denominator is 5. (Select an incremental type encoder)</p>
1-16	MENP	Pulse amount of the motor encoder 1. Set the pulse amount of the motor encoder; 2. Standard configuration of the encoder pulse No. is as below. Incremental encoder omitting wiring: --2000P/R Absolute encoder:--2048P/R		500 to 65535	P/R	

Para. No.	Abbr.	Name	Standard Value	Setting Range	Unit	Remark																																										
2-0	PMOD	<p>Pulse format of position command: Our system uses: direction + pulse format, the parameters are shown as following:</p> <p>The diagram shows the PMOD register bits 7 through 0. Bit 7 is the MSB. Bits 6 and 5 are grouped as 'When bit 7=0'. Bits 4 and 3 are grouped as 'When bit 7=1'. Bits 2 and 1 are grouped as 'Command Pulse Format'. Bit 0 is 'Switch of Digital Filter'. Below are tables for these settings:</p> <table border="1"> <caption>When bit 7=0</caption> <thead> <tr> <th>Bit 1</th> <th>Bit 0</th> <th>Command Pulse Input Digital Filter Min. Pulse Width</th> </tr> </thead> <tbody> <tr><td>0</td><td>0</td><td>0.8μs</td></tr> <tr><td>0</td><td>1</td><td>0.2μs</td></tr> <tr><td>1</td><td>0</td><td>0.4μs</td></tr> <tr><td>1</td><td>1</td><td>1.6μs</td></tr> </tbody> </table> <table border="1"> <caption>When bit 7=1</caption> <thead> <tr> <th>Bit 1</th> <th>Bit 0</th> <th>Command Pulse Input Digital Filter Min. Pulse Width</th> </tr> </thead> <tbody> <tr><td>0</td><td>0</td><td>3.2μs</td></tr> <tr><td>0</td><td>1</td><td>0.8μs</td></tr> <tr><td>1</td><td>0</td><td>1.6μs</td></tr> <tr><td>1</td><td>1</td><td>6.4μs</td></tr> </tbody> </table> <table border="1"> <caption>Command Pulse Format</caption> <thead> <tr> <th>Bit6</th> <th>Bit5</th> <th>Command Pulse Format</th> </tr> </thead> <tbody> <tr><td>1</td><td>0</td><td>Direction + Pulse</td></tr> </tbody> </table> <table border="1"> <caption>Switch of Digital Filter</caption> <thead> <tr> <th>Bit</th> <th>Filter</th> </tr> </thead> <tbody> <tr><td>0</td><td>High Speed</td></tr> <tr><td>1</td><td>Low Speed (1/4)</td></tr> </tbody> </table>	Bit 1	Bit 0	Command Pulse Input Digital Filter Min. Pulse Width	0	0	0.8μs	0	1	0.2μs	1	0	0.4μs	1	1	1.6μs	Bit 1	Bit 0	Command Pulse Input Digital Filter Min. Pulse Width	0	0	3.2μs	0	1	0.8μs	1	0	1.6μs	1	1	6.4μs	Bit6	Bit5	Command Pulse Format	1	0	Direction + Pulse	Bit	Filter	0	High Speed	1	Low Speed (1/4)				
Bit 1	Bit 0	Command Pulse Input Digital Filter Min. Pulse Width																																														
0	0	0.8μs																																														
0	1	0.2μs																																														
1	0	0.4μs																																														
1	1	1.6μs																																														
Bit 1	Bit 0	Command Pulse Input Digital Filter Min. Pulse Width																																														
0	0	3.2μs																																														
0	1	0.8μs																																														
1	0	1.6μs																																														
1	1	6.4μs																																														
Bit6	Bit5	Command Pulse Format																																														
1	0	Direction + Pulse																																														
Bit	Filter																																															
0	High Speed																																															
1	Low Speed (1/4)																																															
4-3	TYPE	<p>Control mode: *Select one control mode from position, velocity, and torque modes.</p> <table border="1"> <thead> <tr> <th>Selection Item</th> <th>Content</th> </tr> </thead> <tbody> <tr><td>Position</td><td>Position control mode</td></tr> <tr><td>Velocity</td><td>Velocity control mode</td></tr> <tr><td>Torque</td><td>Torque control mode</td></tr> <tr><td>Velo ↔ Torq</td><td>Velocity ↔ Torque switch mode</td></tr> <tr><td>Posi ↔ Torq</td><td>Position ↔ Torque switch mode</td></tr> <tr><td>Posi ↔ Velo</td><td>Position ↔ Velocity switch mode</td></tr> </tbody> </table> <p>Referring to the switch type, the requisite control mode can be selected from pin 36 or 35 of the CN1. Func3, set Bit7 as 0: pin 36 is enabled. set Bit7 as 1: pin 35 is enabled.</p> <p>\$\$\$ : standard value varies with the reset setup (leave factory setting).</p>	Selection Item	Content	Position	Position control mode	Velocity	Velocity control mode	Torque	Torque control mode	Velo ↔ Torq	Velocity ↔ Torque switch mode	Posi ↔ Torq	Position ↔ Torque switch mode	Posi ↔ Velo	Position ↔ Velocity switch mode			6 types	Our system selects position control mode.																												
Selection Item	Content																																															
Position	Position control mode																																															
Velocity	Velocity control mode																																															
Torque	Torque control mode																																															
Velo ↔ Torq	Velocity ↔ Torque switch mode																																															
Posi ↔ Torq	Position ↔ Torque switch mode																																															
Posi ↔ Velo	Position ↔ Velocity switch mode																																															

## 5.2.15 Parameter Setting of SANYO R Servo Driver

Para. No.	Parameter Name	Set Value	Remarks
Group 0, parameter setting of tuning mode			
00	Setting of the tuning mode	00	Set as auto tuning mode
Group 8, setting of the control parameters			
00	Polarity of position input	00	Position command mode: positive rotation effective
11	Input command mode	02	Pulse + negative logic
15	Setting of electronic gear	8/5	It depends on the resolution of the specific encoder. E.G.: incremental encoder 2000, the motor needs $2000 \times 4 = 8000$ pulses per circle. When pulse equivalent of Weihong CNC system is 0.001mm/p, it needs 1000 pulses to move 1mm along line; in other words, if the screw pitch is 5, so, to move 5mm along line needs 5000 pulses, so $F = 8000 / 5000 = 8/5$ .
Group 9, setting of function effective			
05	Servo ON selection	02	Select servo ON state.
02	Servo alarm elimination	10	Make the function of servo alarm effective.
Setting of the system parameters			
02	Encoder selection	00	Standard incremental encoder. The parameter depends on the specific situation, what we list is only the representative one.
03	Encoder resolution	2000	500—65535, set the encoder resolution manually.
08	Control mode selection	02	Select position control mode.



## 5.2.16 Parameter Setting of SANYO Q Servo Driver

Para. No.	Parameter Name	Set Value	Remarks
Group 1			
<b>GER1</b>	Electronic gear ratio 1	1/1	Set electronic gear ratio for position command pulse. E.G., incremental encoder 2000, the motor needs $2000 \times 4 = 8000$ pulses per circle. When pulse equivalent of Weihong CNC system is 0.001mm/p, it needs 1000 pulses to move 1mm along line, in other words, if the screw pitch is 5, to move 5mm along line needs 5000 pulses, so $F = 8000/5000 = 8/5$ .
<b>GER2</b>	Electronic gear ratio 2	1/1	This setting is the same as that of electronic gear ratio 1 and activated during electronic gear switching.
Group 4			
<b>PA400</b>	Command pulse selection	00H	Set position command pulse as "pulse + direction".
Group 8			
<b>S-ON</b>	Servo ON	02H	Select servo ON state.
<b>AL-RST</b>	Alarm reset	10H	Make the function of servo alarm effective.
Setting of the system parameters			
<b>01</b>	Encoder selection	00	Standard incremental encoder. The parameter depends on the specific situation, what we list is only the representative one.
<b>03</b>	Incremental encoder resolution	2000	500—65535, set the encoder resolution manually.
<b>08</b>	Control mode selection	02	Select position control mode.

### 5.2.17 Parameter Setting of KT270 Servo Driver

Para. No.	Parameter Name	Value	Description
PA4	Control mode selection	0	The control mode of the driver can be set through this parameter: 0: position control mode; 1: speed control mode; 2: trial run control mode; 3: JOG control mode.
PA12	Numerator of position command pulse ratio	2	Set the ratio of the position command pulse (electronic gear). Under position control mode, with the setting of the PA12 and PA13, it is convenient to match with pulse source of each type, which can reach users' perfect control resolution (that is angle/pulse). Expression: $P \times G = N \times C \times 4$ P: pulse amount of the input command; G: electronic gear ratio, G=ratio numerator / ratio denominator. N: circle number that the motor rotates; C: each circle line number of photo electricity encoder, C of our system =2500. E.G.: input command pulse with number of 6000 to make the servo motor rotate one circle, $G = \frac{N \times C \times 4}{P} = \frac{1 \times 2500 \times 4}{6000} = \frac{5}{3}$ So set PA12 as 5 and PA13 as 3. We recommend the range of electronic gear ratio as: $\frac{1}{50} \leq G \leq 50$
PA13	Denominator of the position command pulse ratio	1	Refer to parameter PA12.
PA14	Input mode of the position command pulse	0	Set the input mode of the position command pulse; there are following three modes which can be selected by setting the parameter: 0: pulse + symbol; 1: positive rotation pulse / negative rotation pulse; 2: two orthogonal pulses inputs









Para. No.	Parameter Name	Value	Description
PA20	Invalid input on the end of the stroke	1	<p>0: Valid stroke end of LSP, LSN positive rotation, negative rotation.</p> <p>When switch LSP is connected, driving of the positive rotation is allowed; When switch LSP is disconnected, driving of the positive rotation is prohibited (torque of the positive direction is 0). LSN is the same as LSP. If LSP and LSN are both disconnected, the abnormal alarming of driving prohibited will occur (NO.7).</p> <p>1: Invalid stroke end of LSP, LSN positive rotation, negative rotation.</p> <p>No matter which state of the switch LSP and LSN is in, driving of positive rotation and negative rotation are both allowed. Simultaneously, even if LSP and LSN are both disconnected, abnormal alarming of driving prohibited will not occur (NO.7).</p> <p>2: Invalid stroke end of LSP, LSN positive rotation, negative rotation, and SON is forced to be effective. (Note: SON forcedly effective is only used for motor debugging. In normal use, we suggest controlling the state of SON by input port.)</p> <p>3: Valid stroke end of LSP, LSN positive rotation, negative rotation.</p> <p>When switch LSP is connected, driving of the positive rotation is allowed; When switch LSP is disconnected, driving of the positive rotation is prohibited (the speed of positive direction is 0, but the torque is not 0). LSN is the same as LSP. When LSP and LSN are both disconnected, abnormal alarming of driving prohibited will not occur (NO.7).</p>

## 5.2.18 Parameter Setting of FUJI FALDIC-β Servo Driver

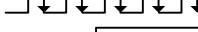
Para. No.	Name	Value	Description
01	Command pulse numerator $\alpha$	Need calculation 1~32767	Command pulse numerator and denominator are also equal to those of the electronic gear ratio. $\alpha / \beta = \text{encoder resolution} \times \text{pulse equivalent} \times \text{mechanical deceleration ratio} / \text{screw pitch}$ .
02	Command pulse denominator $\beta$	Need calculation 1~32767	Typical value: encoder resolution 65536, pitch 5mm, pulse equivalent 0.001mm/p, mechanical deceleration ratio 1, $\alpha / \beta = 65536 \times 0.001 / 5 = 8192 / 625$ , So $\alpha = 8192$ , $\beta = 625$ .
03	Pulse string input form	0	Set the input mode of pulse string as: instruction + symbol, that is 'pulse + direction'.
04	Direction of rotation switch	0 or 1	Set 0: Positive direction: Forward rotation (CCW); Set 1: Positive direction: Reverse rotation (CW).
10	CONT1 signal distribution	1	CONT1 is distributed as RUN (i.e. SON); if not distributed, CONT1 will be auto ON if there is no alarming when powered.
11	CONT2 signal distribution	2	CONT2 is distributed as RST (i.e. servo alarming clearance CLR). When 12, 13, 14 are 0, that is CONT3, CONT4 and CONT5 can't be distributed as OT over-travel or EMG (external emergency stop).
15	OUT1 signal distribution	1	Set 1, OUT1 is distributed as a-contact point of alarming output; Set 2, OUT1 is distributed as b-contact point of alarming detection.
27	Parameter write-protection	0 or 1	Set 0, write-enable. Set 1, write-protected.
74	CONT Always ON 1	1	Its initial value is 0, and it is set "1" here to enable servo (RUN).

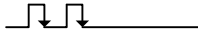
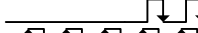
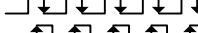
## 5.2.19 Parameter Setting of Stone GS Servo Driver

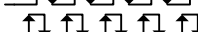
Para. No.	Para. Name	Value	Description																							
F0f	Electronic gear ratio numerator	2	Electronic gear ratio of position mode: $4 \times \text{pulse frequency fed back by servo encoder} = \text{command pulse frequency} \times F0f / F10$ ; value of $F0f / F10$ must be within $1/100 \sim 100$ . (calculation with pitch as 10mm)																							
F10	Electronic gear ratio denominator	1																								
F00	Control mode selection	2	<p>0: External speed running mode; make sure the value and direction of motor speed according to the external analog <math>-10V \sim +10V</math> signal of CN2-16, 17;</p> <p>1: Internal speed running mode; make sure the value and direction of motor speed according to the setting of parameter F33, F35, F37, F39 and the port status of CN2-9, CN2-25;</p> <p>2: Position pulse running mode; accept the input of external position pulse and direction level signal;</p> <p>3: Jog mode; make sure the motor speed in terms of parameter setting of F3b, and control the rotation direction by the direction keystroke ▼ and ▲;</p> <p>4: Torque mode; make sure the value and direction of motor torque according to the external analog <math>-10V \sim +10V</math> signal of CN2-43, 1;</p> <p>5~10: Mixed mode; select mode according to the port input status of CN2-24:</p> <table border="1" data-bbox="651 1294 1401 1608"> <thead> <tr> <th rowspan="2">F00 Value</th> <th colspan="2">CN2-24 Interface Status</th> </tr> <tr> <th>OFF (Mode One)</th> <th>ON (Mode Two)</th> </tr> </thead> <tbody> <tr> <td>5</td> <td>Position Pulse Mode</td> <td>External Speed Running Mode</td> </tr> <tr> <td>6</td> <td>Position Pulse Mode</td> <td>Internal Speed Running Mode</td> </tr> <tr> <td>7</td> <td>Position Pulse Mode</td> <td>Torque Mode</td> </tr> <tr> <td>8</td> <td>Internal Speed Running Mode</td> <td>External Speed Running Mode</td> </tr> <tr> <td>9</td> <td>Internal Speed Running Mode</td> <td>Torque Mode</td> </tr> <tr> <td>10</td> <td>External Speed Running Mode</td> <td>Torque Mode</td> </tr> </tbody> </table>	F00 Value	CN2-24 Interface Status		OFF (Mode One)	ON (Mode Two)	5	Position Pulse Mode	External Speed Running Mode	6	Position Pulse Mode	Internal Speed Running Mode	7	Position Pulse Mode	Torque Mode	8	Internal Speed Running Mode	External Speed Running Mode	9	Internal Speed Running Mode	Torque Mode	10	External Speed Running Mode	Torque Mode
F00 Value	CN2-24 Interface Status																									
	OFF (Mode One)	ON (Mode Two)																								
5	Position Pulse Mode	External Speed Running Mode																								
6	Position Pulse Mode	Internal Speed Running Mode																								
7	Position Pulse Mode	Torque Mode																								
8	Internal Speed Running Mode	External Speed Running Mode																								
9	Internal Speed Running Mode	Torque Mode																								
10	External Speed Running Mode	Torque Mode																								

Para. No.	Para. Name	Value	Description	
<b>F2e</b>	Pulse input mode selection	2	Command pulse string mode selection of position mode:	
			1 - Single pulse train positive logic	Pulse <b>12</b> <b>27</b>  Direction <b>13</b> <b>28</b> 
			2 - Single pulse train negative logic	Pulse <b>12</b> <b>27</b>  Direction <b>13</b> <b>28</b> 
			3 - Double pulse train positive logic	CCW <b>12</b> <b>27</b>  CW <b>13</b> <b>28</b> 
			4 - Double pulse train negative logic	CCW <b>12</b> <b>27</b>  CW <b>13</b> <b>28</b> 
			5 - Orthogonal pulse positive logic	Phase A <b>12</b> <b>27</b>  Phase B <b>13</b> <b>28</b> 
			6 - Orthogonal pulse negative logic	Phase A <b>12</b> <b>27</b>  Phase B <b>13</b> <b>28</b> 

## 5.2.20 Parameter Setting of TECO TSDA Servo Driver

Para. No.	Function	Value	Description		
Pn010-1	Set control mode	1	Control mode		
			Value	CN1 Pin12 open circuit	CN1 Pin12 closed circuit
			0	Speed control	Speed control
			1	Position control	Position control
			2	Torque control	Torque control
			3	Speed control	Speed control
			4	Position control	Position control
Pn010-2	Set the pulse input format under position control mode	0	Value	The format of pulse input	
			0	Pulse + direction	
			1	Dipulse	
			2	A/B phase difference	
Pn010-3	Set rotation direction of motor	1	Value	Function	
			0	Motor rotates CCW with input of positive order.	
			1	Motor rotates CW with input of positive order.	
Pn021	Electronic gear ratio numerator	5	The input pulse amount will be multiplied by this number before output. Ratio range of parameter 21 to 22: $1/127 < \text{parameter 21} / \text{parameter 22} < 127$		
Pn022	Electronic gear ratio denominator	1			
Pn011-4	Set the function of Pin20 of CN1	1	Value	Function	
			0	Output of "0" speed signal	
			1	Output of brake signal	
Pn013-1	Set the max. pulse frequency received by the driver under position control mode	7	It can correct the phenomenon of unauthorized over-travel. Received frequency is divided into 8 segments from 500Kpps to 200Kpps. "0" indicates 500Kpps while "7" 200Kpps.		



For the parameter setting of driver of various brands, refer to the specific driver manual.

## 5.3 Wiring Diagrams with Drivers (Lambda 3S/3L)

### 5.3.1 Wiring with Stepping Driver with Common Port

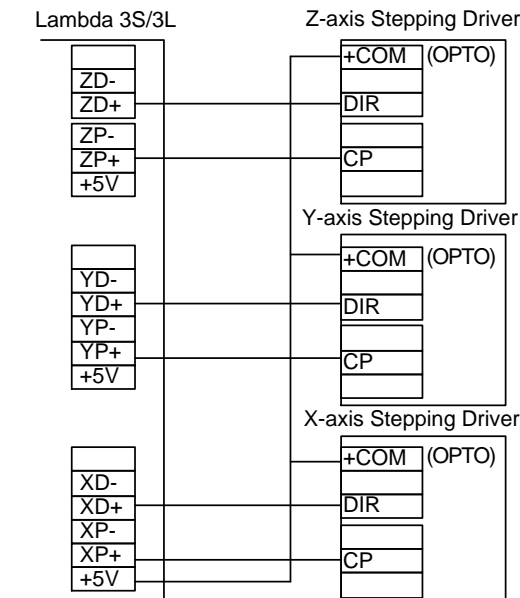

### 5.3.2 Wiring With Differential Input Stepping Driver

It is strongly recommended to connect Lambda 3S/3L with differential input stepping driver following the connection method below, for this connection method can reduce interference effectively.



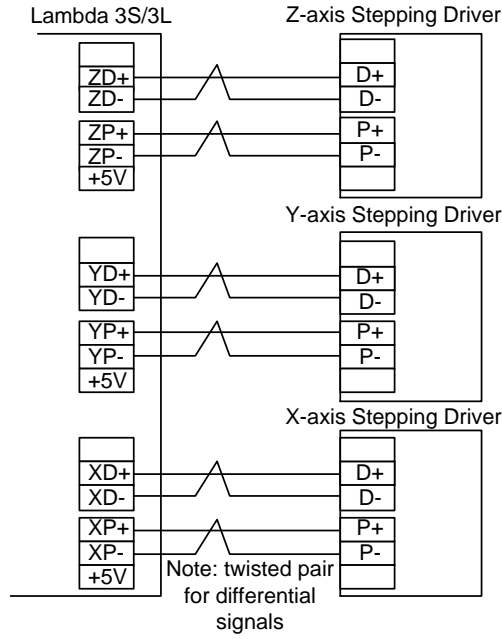

### 5.3.3 Wiring with WISE Servo Driver

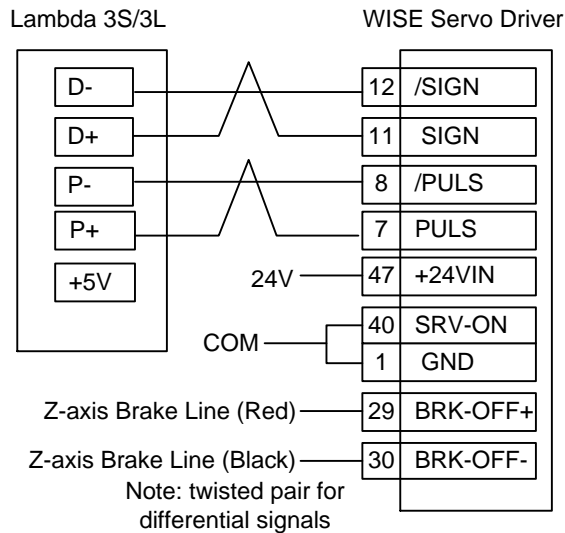

Wirings of X axis, Y axis, and Z axis are the same. Only Z axis has two brake signal lines which can be connected to relay to control brake.

### 5.3.4 Wiring with YASKAWA $\Sigma$ -II Servo Driver

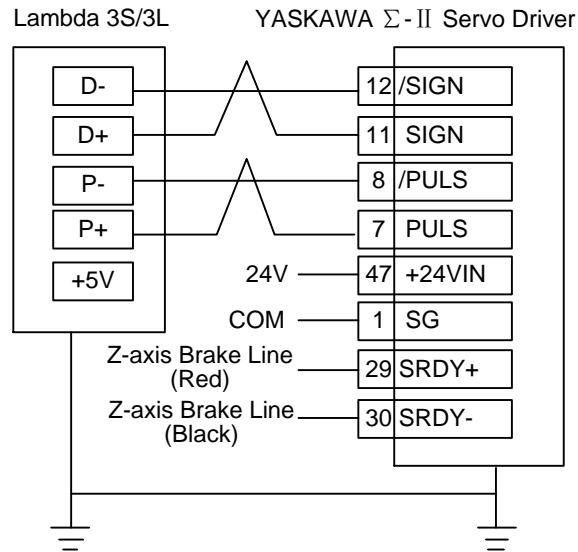

Wirings of X axis, Y axis, and Z axis are the same. Only Z axis has two brake signal lines which can be connected to relay to control brake.

### 5.3.5 Wiring with DELTA ASDA-A/AB Servo Driver

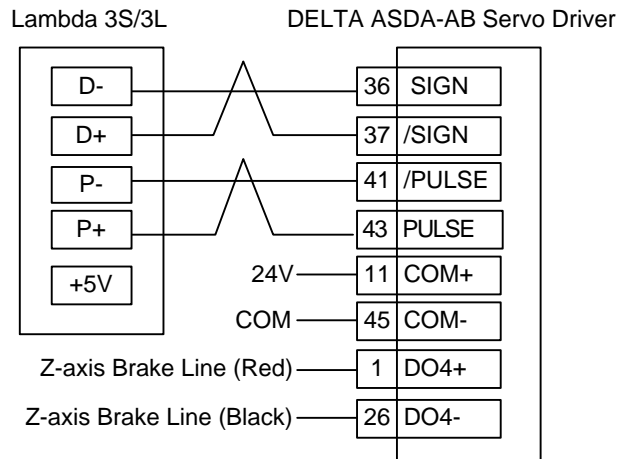
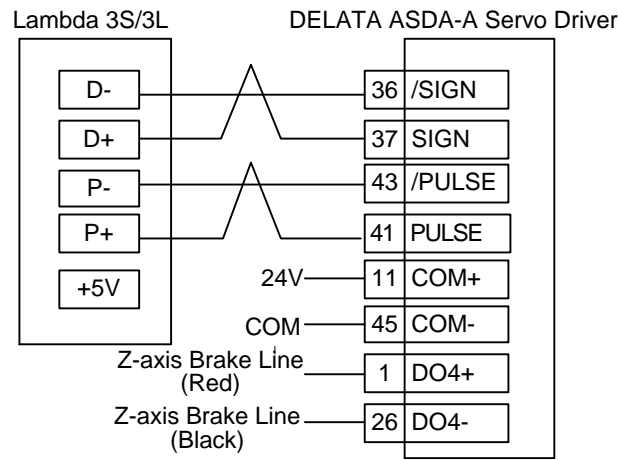

Wirings of X axis, Y axis, and Z axis are the same. Only Z axis has two brake signal lines which can be connected to relay to control brake.

### 5.3.6 Wiring with PANASONIC MINAS A4 Servo Driver

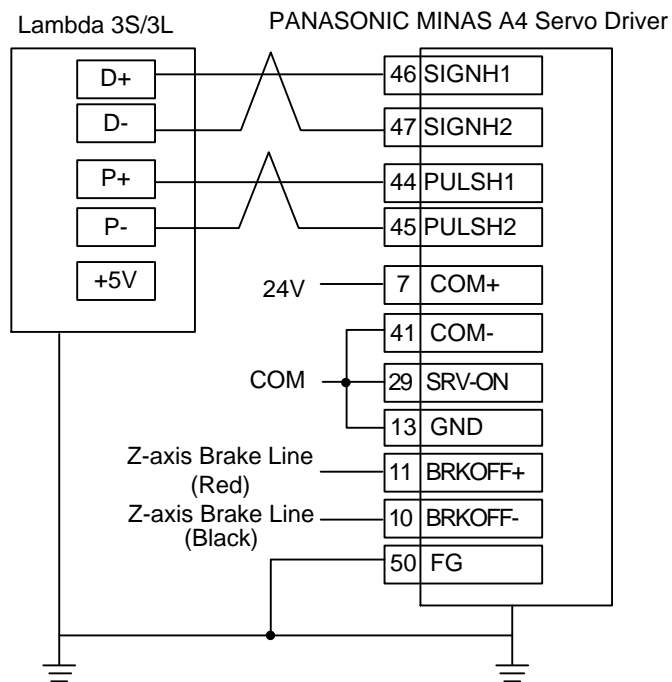

Wirings of X axis, Y axis, and Z axis are the same. Only Z axis has two brake signal lines which can be connected to relay to control brake.

### 5.3.7 Wiring with MITSUBISHI MR-E Servo Driver

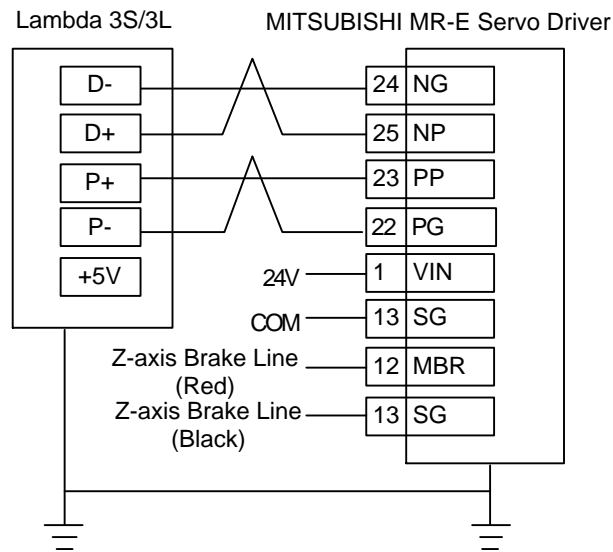

Wirings of X axis, Y axis, and Z axis are the same. Only Z axis has two brake signal lines which can be connected to relay to control brake.

### 5.3.8 Wiring with FUJI FALDIC-β Servo Driver

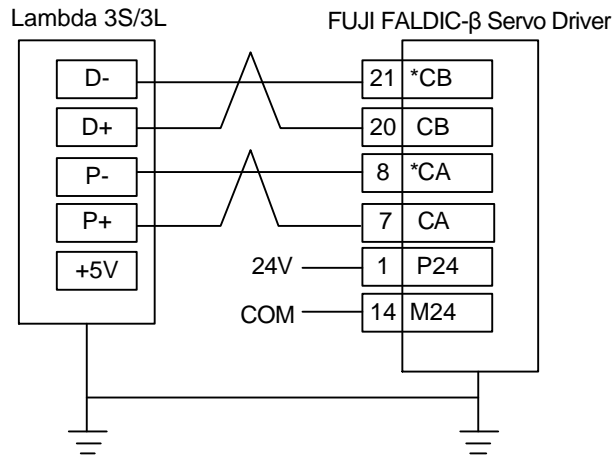

### 5.3.9 Wiring with STONE GS Servo Driver

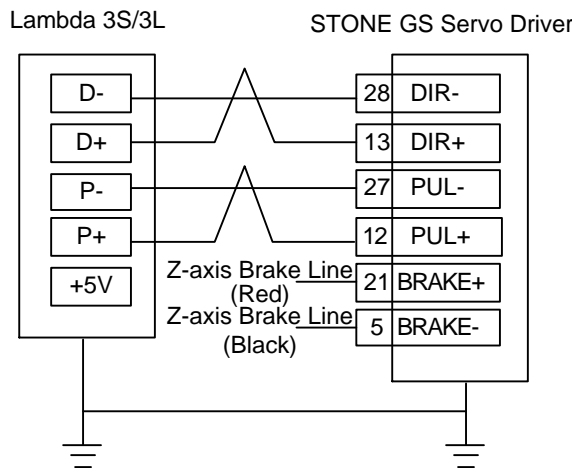

Wirings of X axis, Y axis, and Z axis are the same. Only Z axis has two brake signal lines which can be connected to relay to control brake.

## 5.4 Wiring Diagrams with Drivers (Lambda 4S/5S/5M)

Wiring diagrams in this part are the wiring diagrams of control system-axes control-driver motion. When users want to use one axis of the control system to control the motion of two drivers, the wiring diagram is as shown in Figure 2 in chapter 5.4.2 and Figure 4 in chapter 5.4.6 (take YASKAWA driver and DELTA

driver as an example; for YASKAWA server, its alarm signal wiring is NC type, while for DELTA server, its alarm signal wiring is NO type).

### 5.4.1 Wiring Diagram with WISE Servo Driver

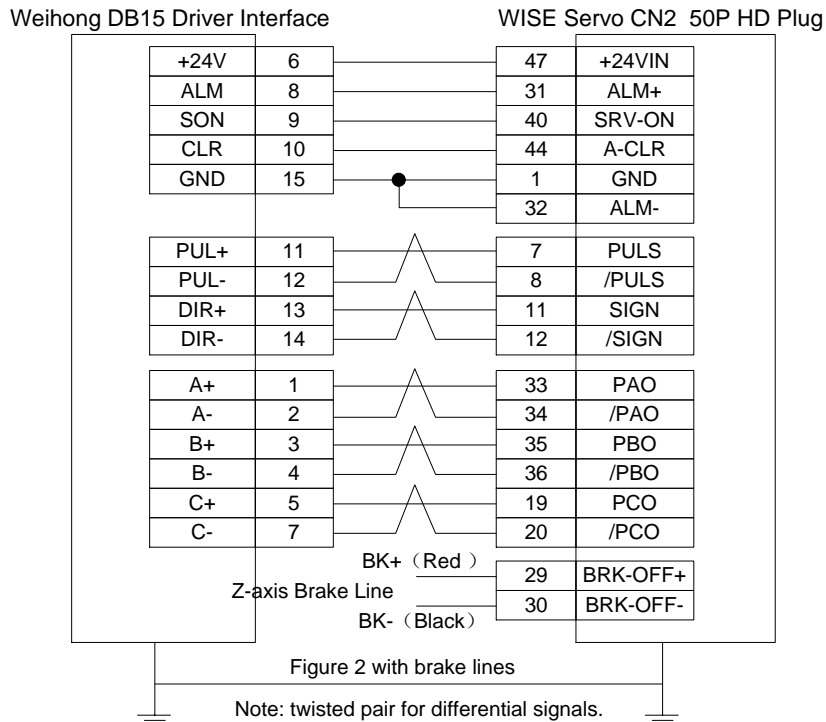
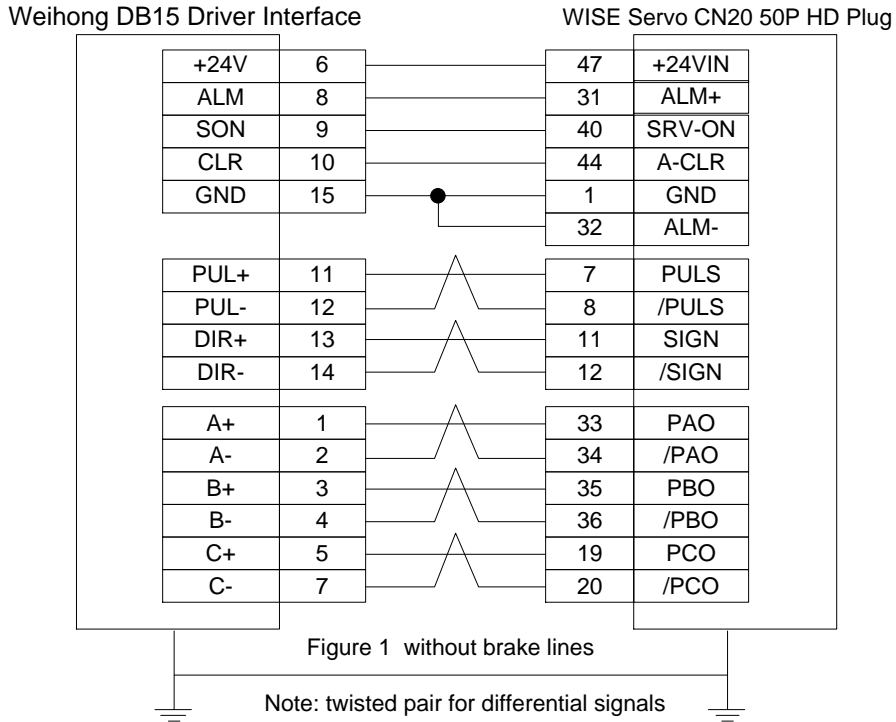

## 5.4.2 Wiring Diagram with YASKAWA AC Servo Driver

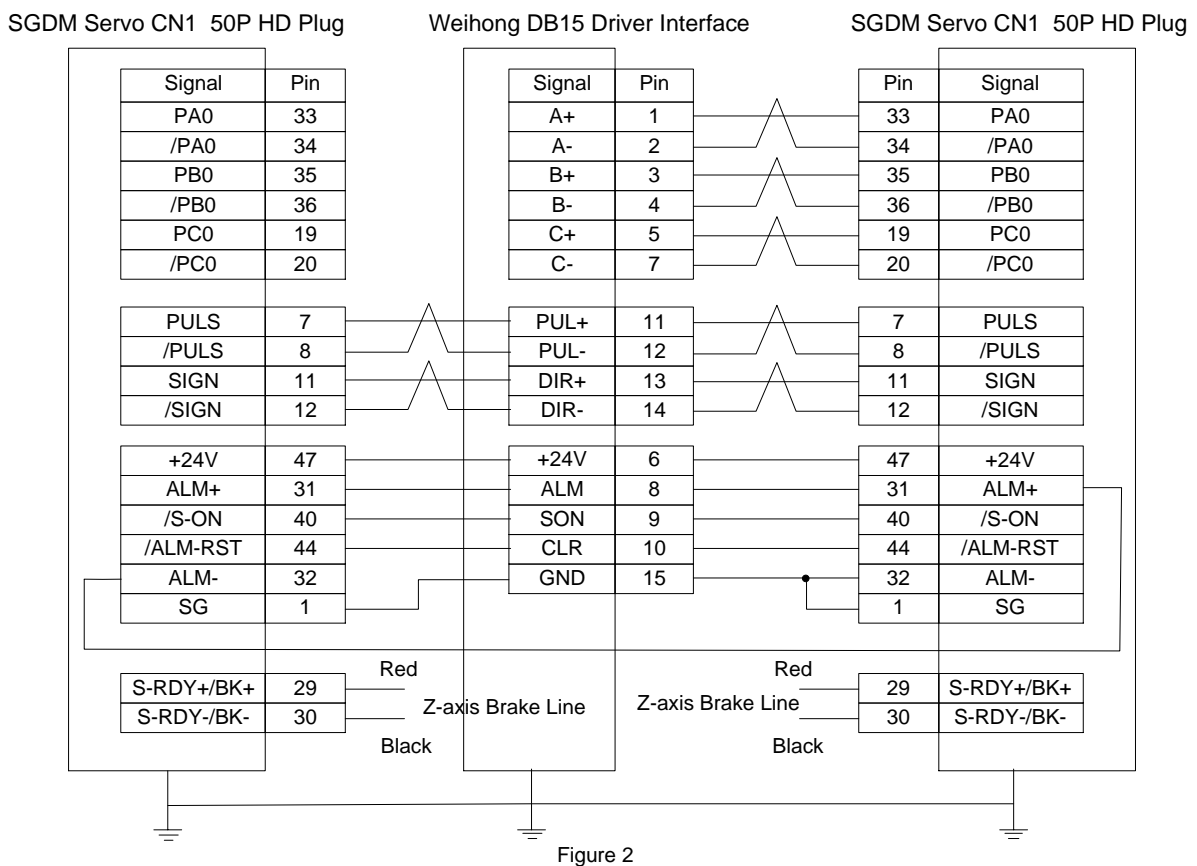
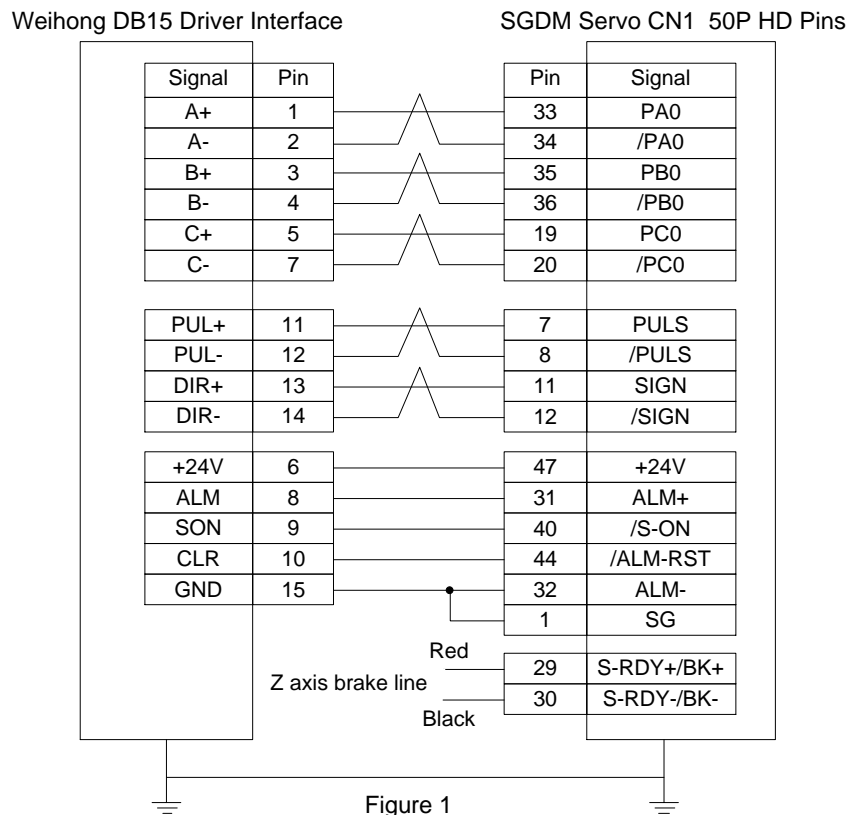



### 5.4.3 Wiring Diagram with PANASONIC AC Servo Driver

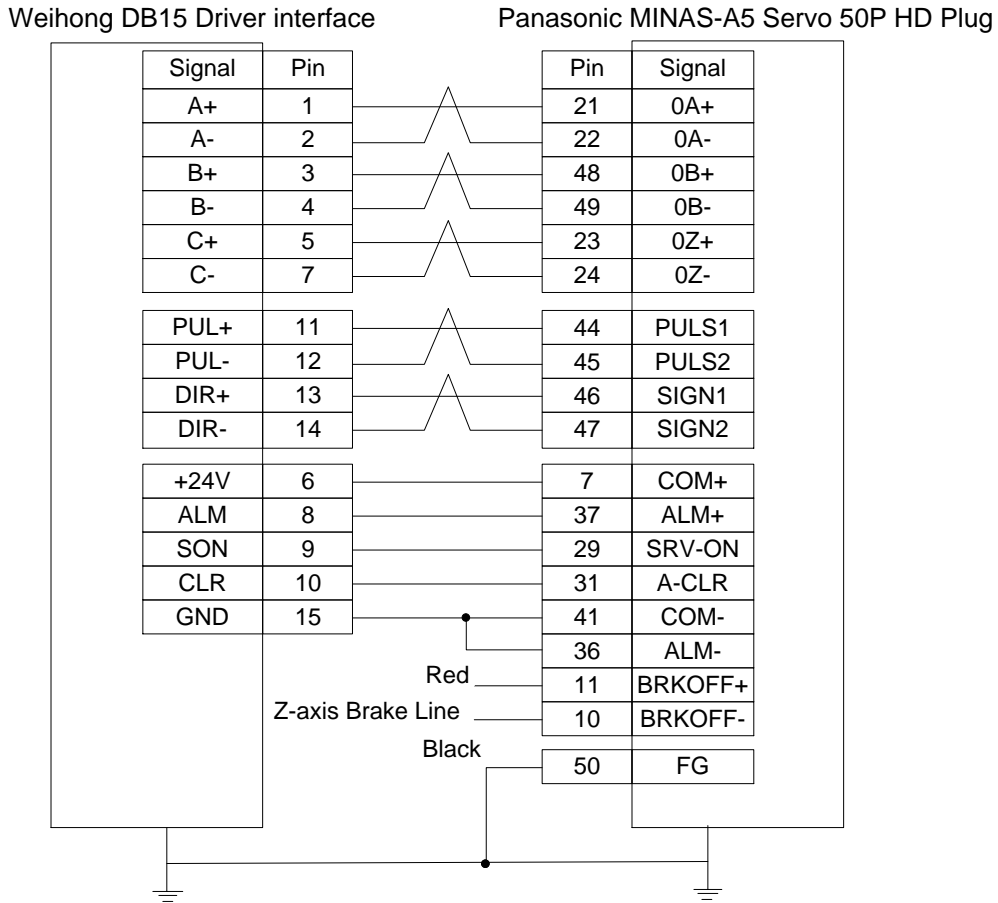

### 5.4.4 Wiring Diagram with MITSUBISHI MR-JE Servo Driver

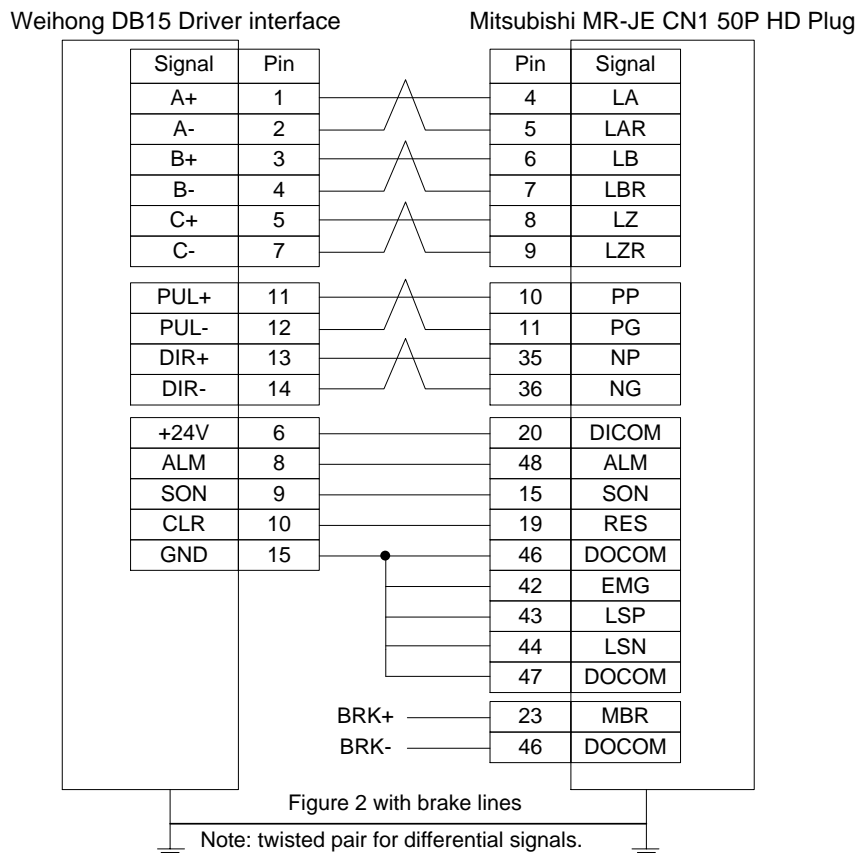
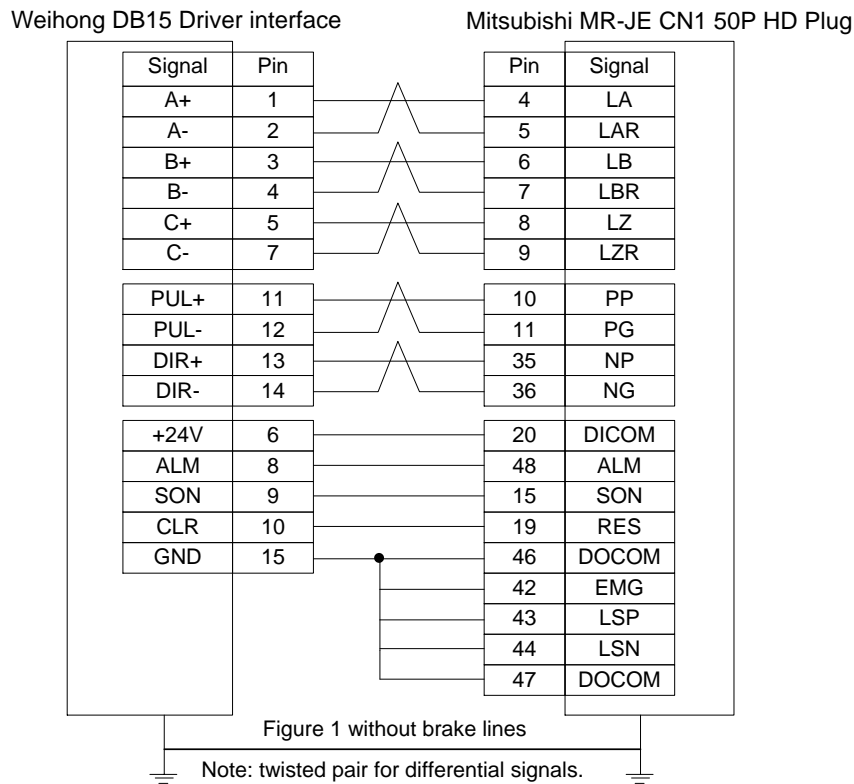

### 5.4.5 Wiring Diagram with MITSUBISHI MR-E Servo Driver

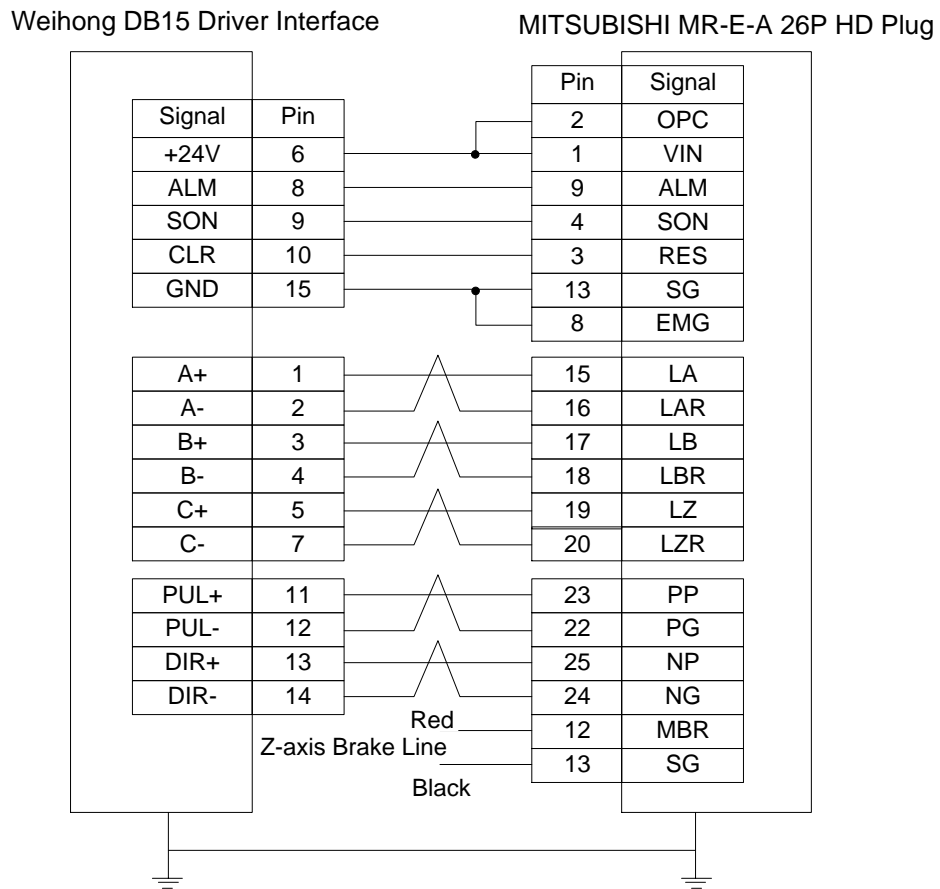

### 5.4.6 Wiring Diagram with DELTA Servo Driver

DELTA ASDA-A, ASDA-A2 and ASDA-AB use the same cable. Among them, the wiring pins of ASDA-A2 and ASDA-AB are totally the same. As for ASDA-A, with PULSE as 41 and /PULSE as 43, its pulse signal pins are opposite to those of ASDA-A2 and ASDA-AB, but the other wiring pins are totally the same. For the detailed parameters settings, see chapter 5.2.10 and chapter 5.2.11.

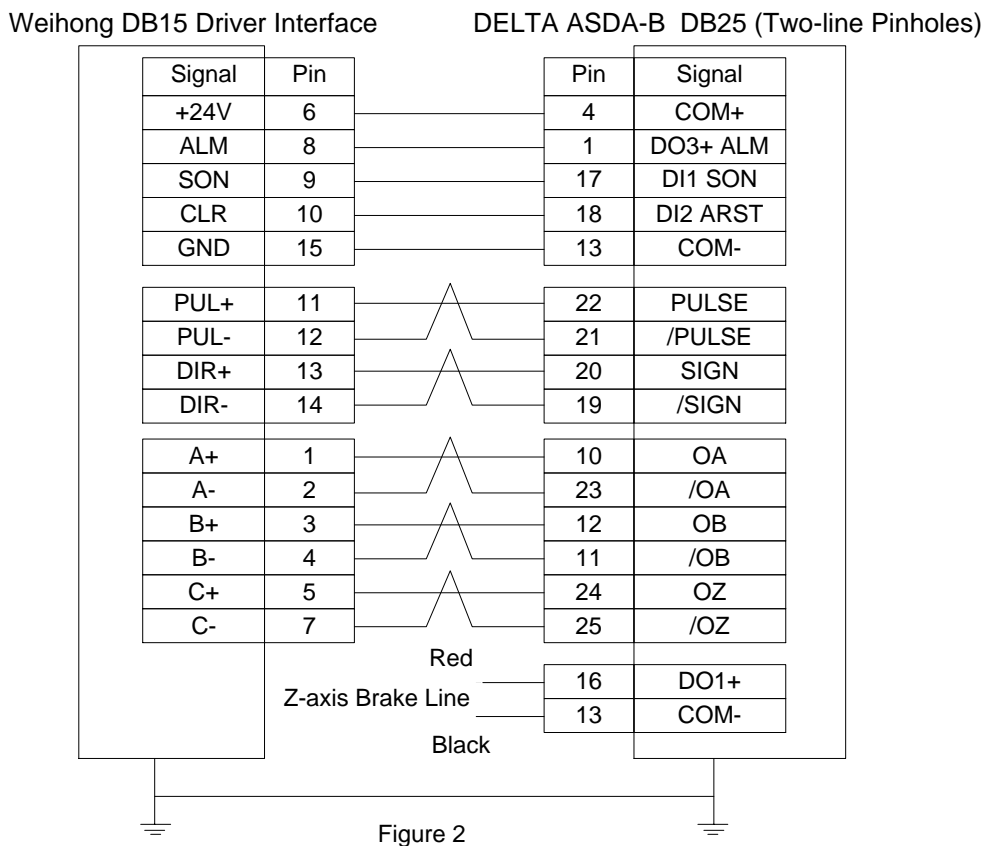
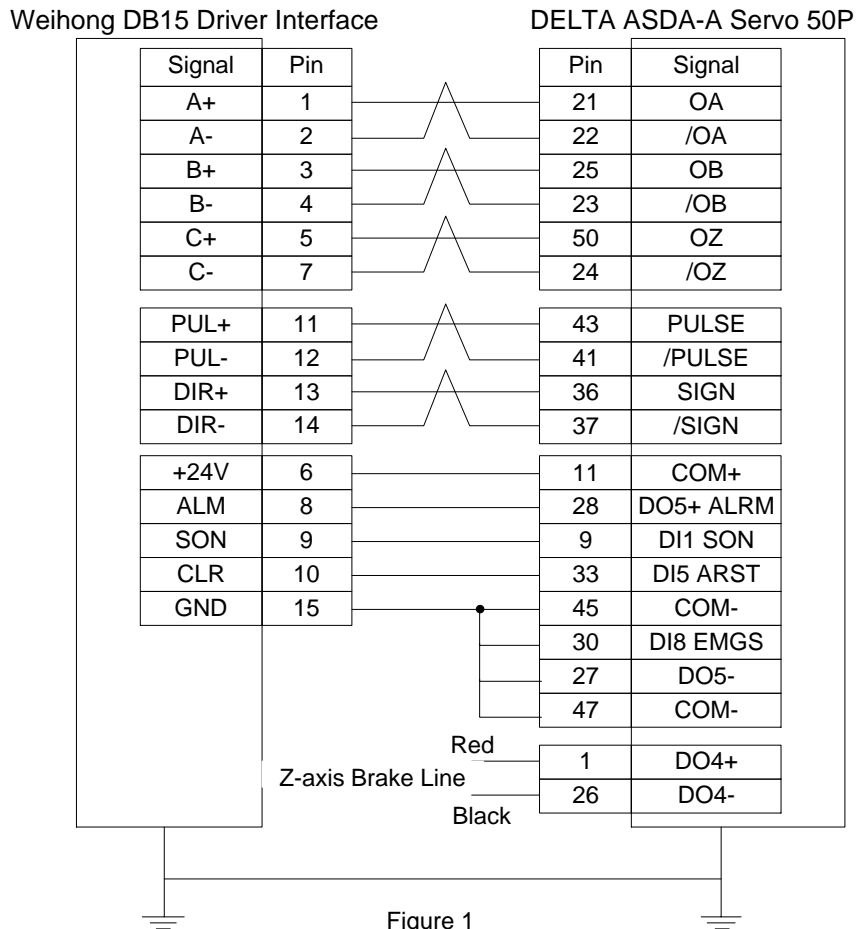

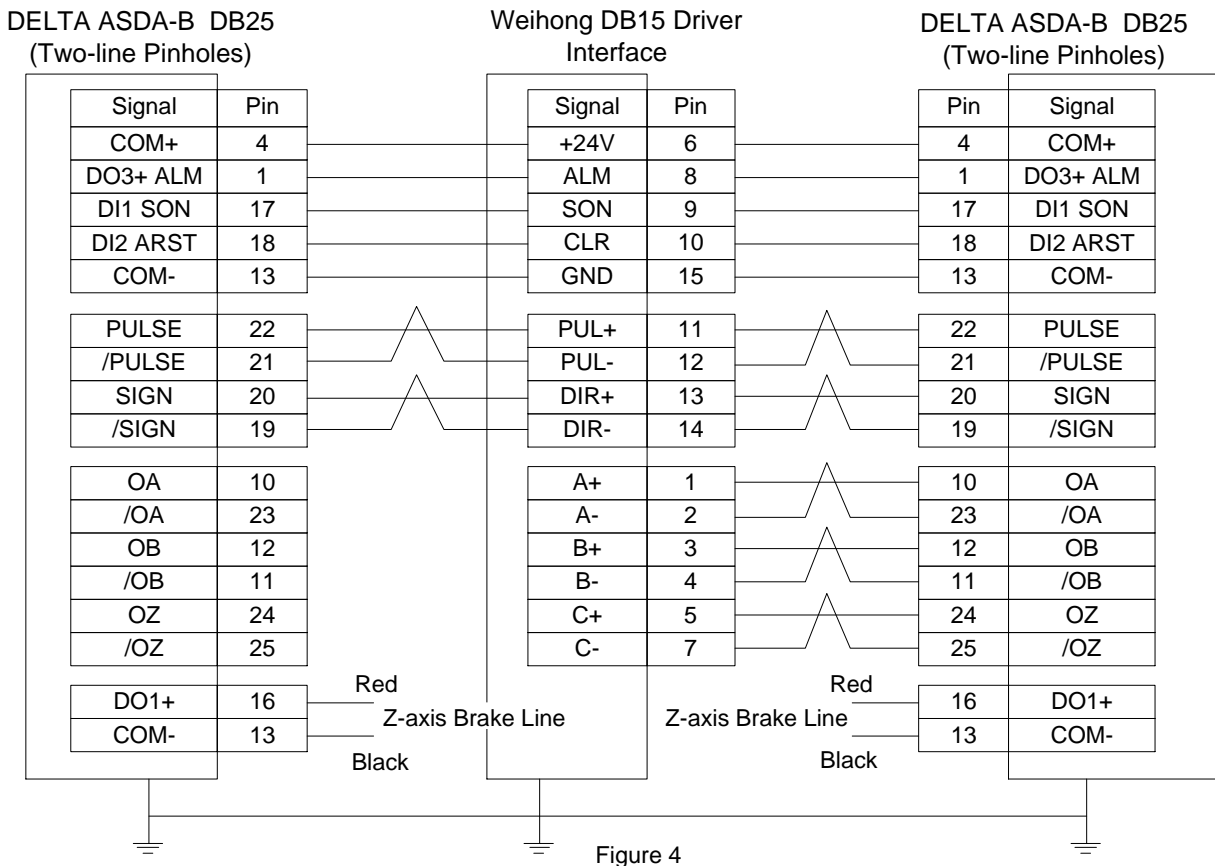
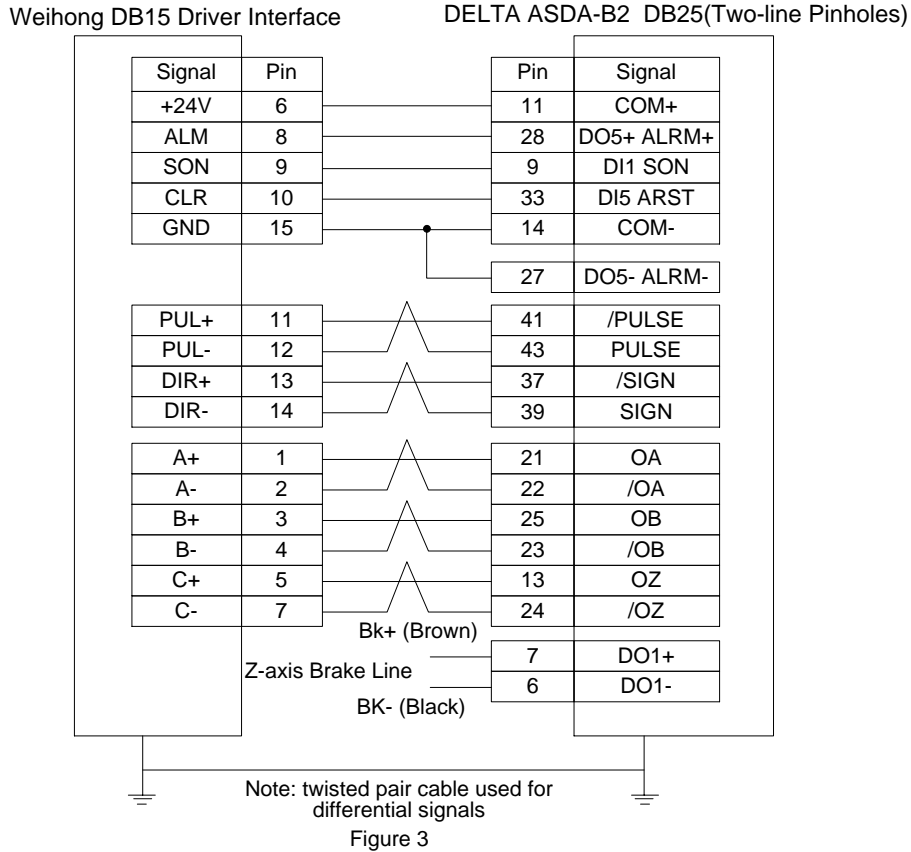

### 5.4.7 Wiring Diagram with FUJI Servo Driver

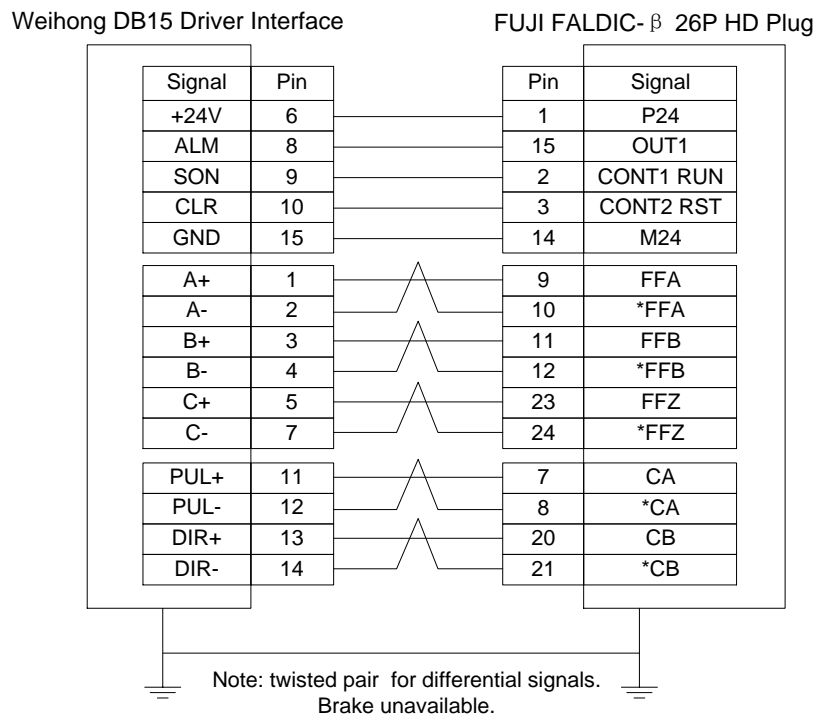

### 5.4.8 Wiring Diagram with HITACHI Servo Driver

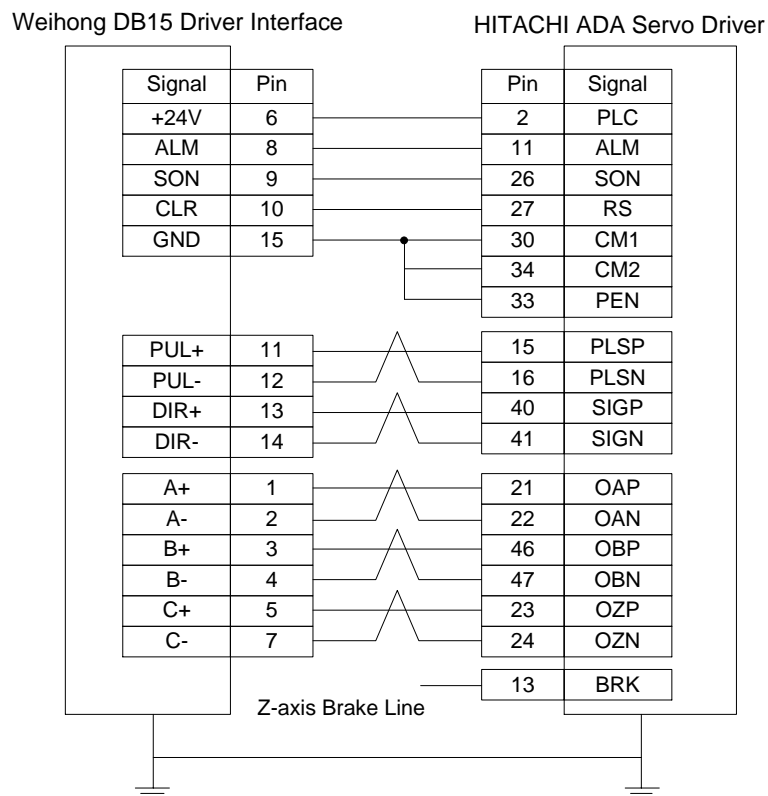

### 5.4.9 Wiring Diagram with SANYO PY Servo Driver

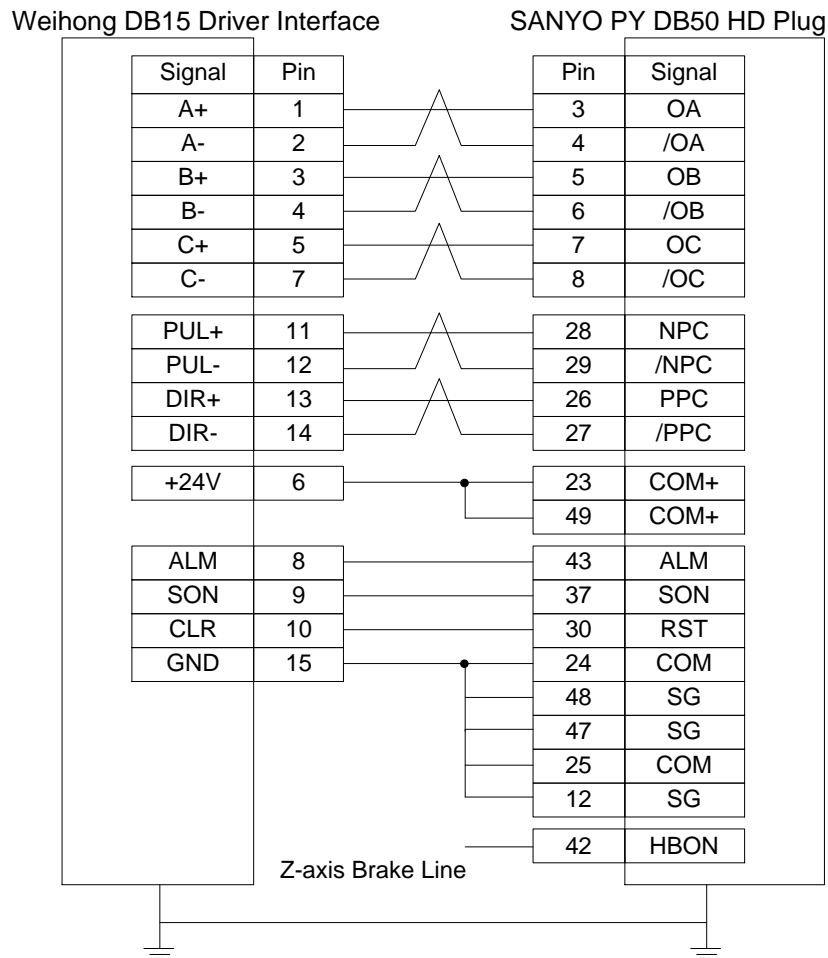

### 5.4.10 Wiring Diagram with SANYO R Servo Driver

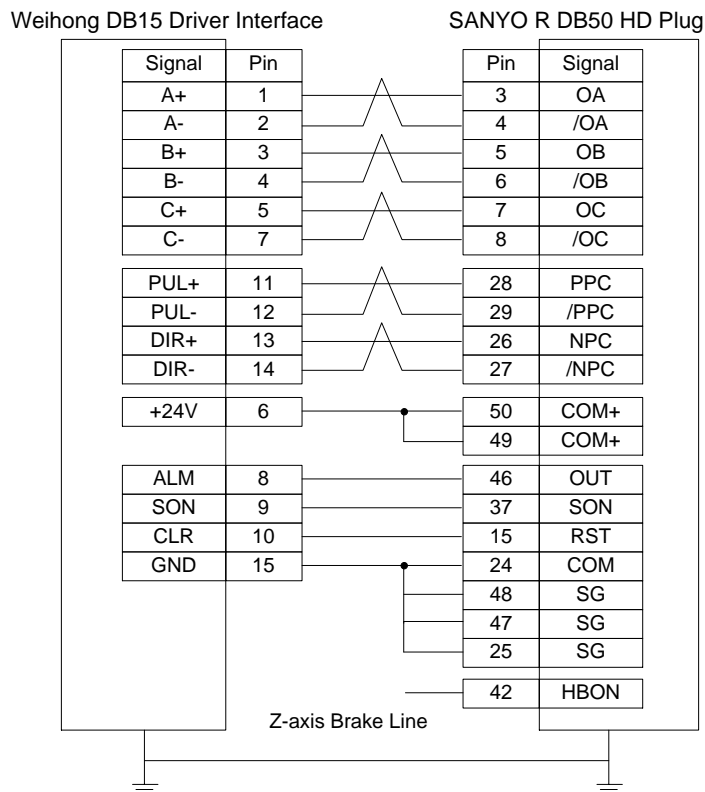

### 5.4.11 Wiring Diagram with KT270 Servo Driver

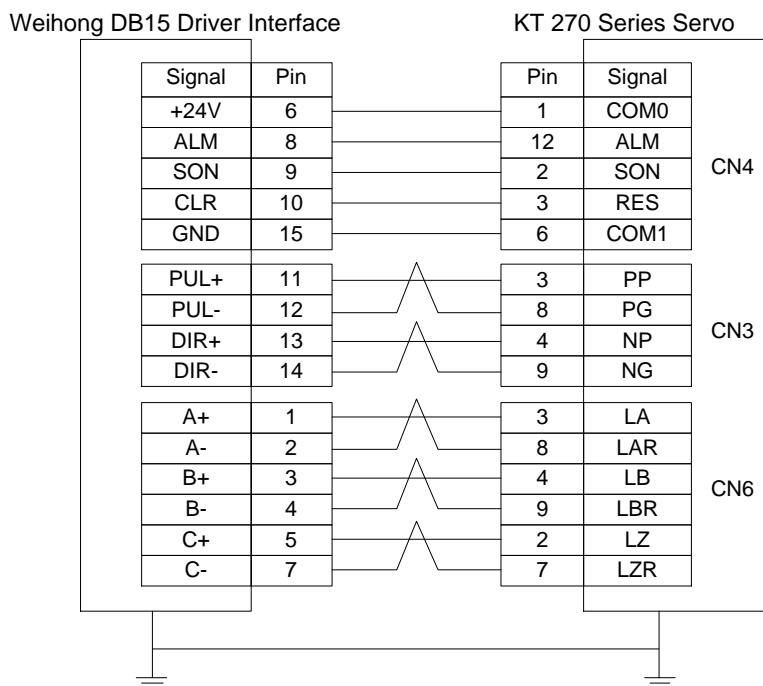



### 5.4.12 Wiring Diagram with STONE GS Servo Driver

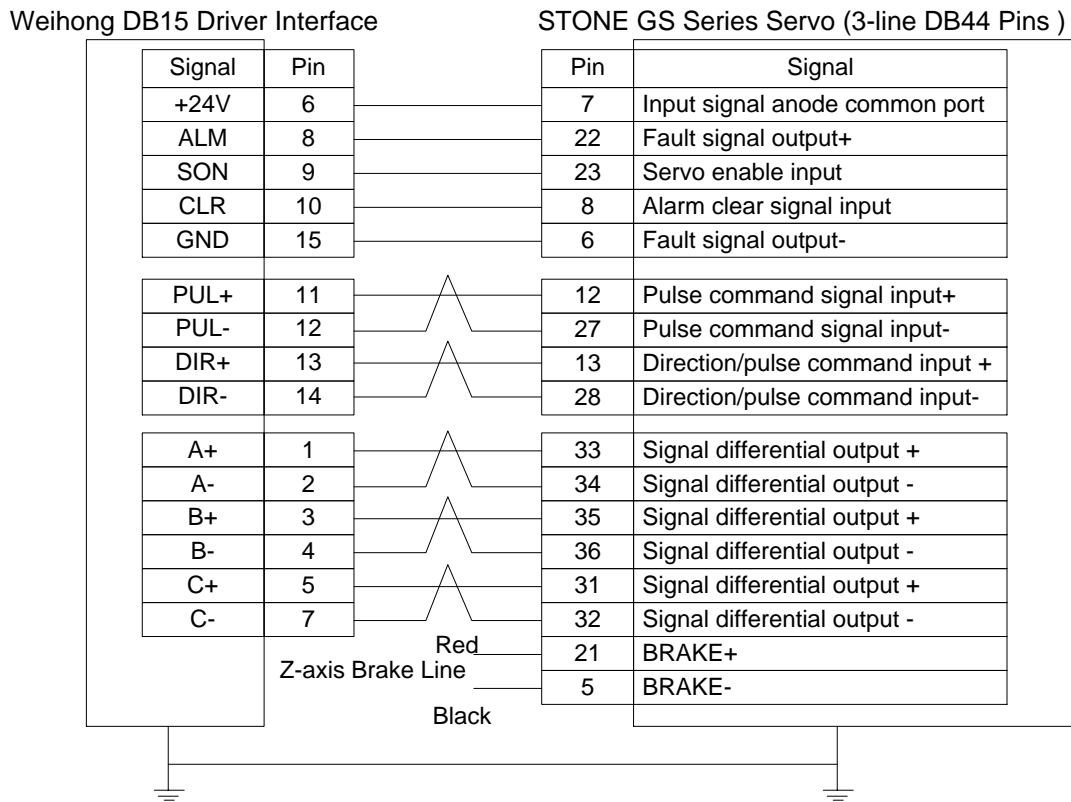

### 5.4.13 Wiring Diagram with TECO TSDA Servo Driver

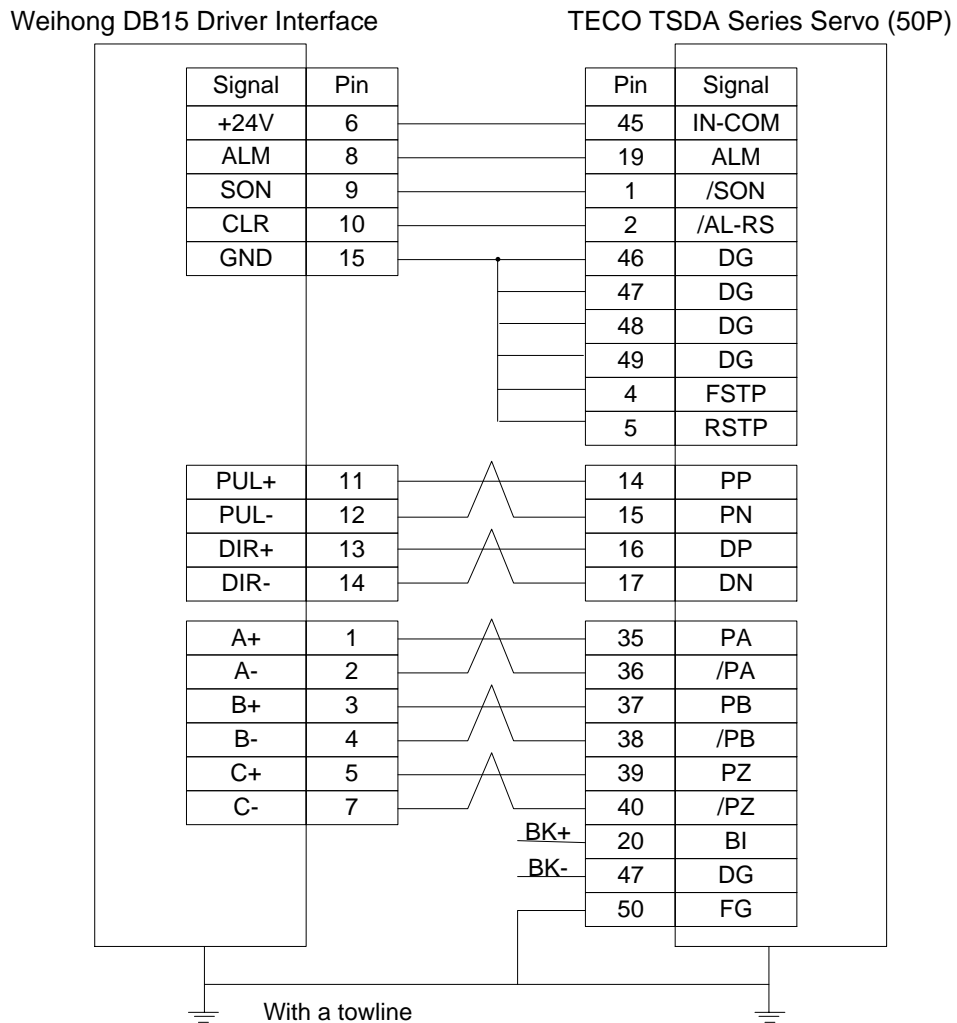

### 5.4.14 Wiring Diagram with TECO ESDA Servo Driver

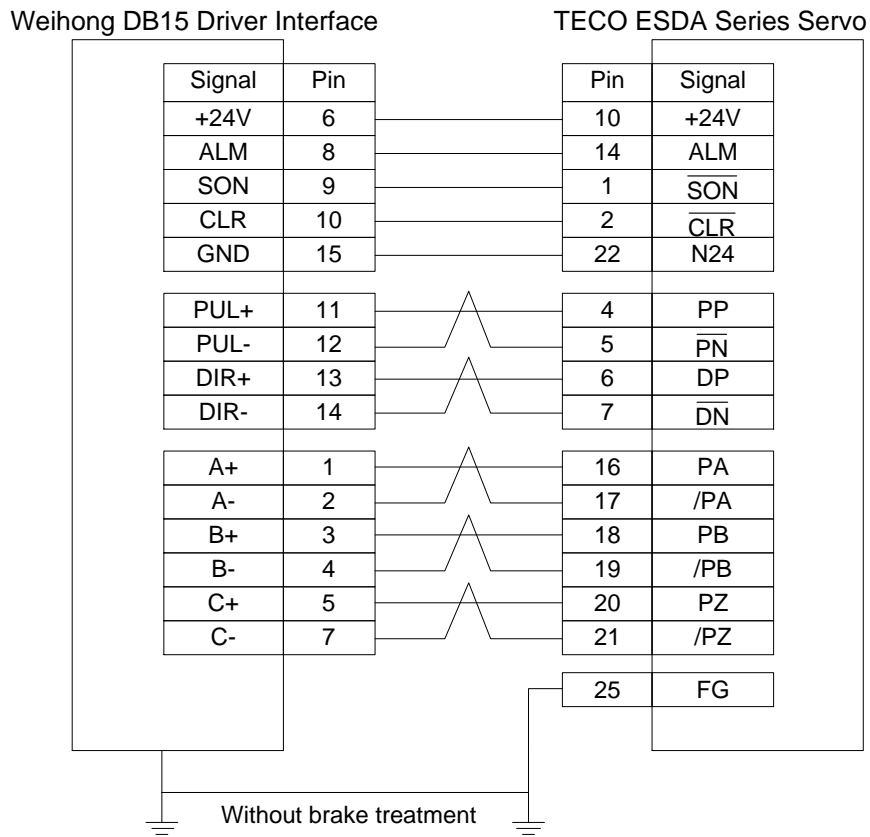

## 6 Appendix

---

### 6.1 Back to Machine Zero (Back to Reference Point)

Machine Zero (also called machine origin, home) is the datum mark of MCS (machine coordinate system). The process of returning to machine zero, varying with different machine structures & control software versions, is achieved via the execution of a block of G codes.

“Back to Reference Point” is a process to synchronize local coordinate system with actual external coordinate system via control system. In other words, since the system does not know the concrete position of each axis after start-up, it will control the motion of each axis and detect the switch signals pre-installed on each axis during the motion (the control system has already known the installation position of these switches). Thus, once these switch signals are found, the system will learn that the machine tool has reached the predetermined position and then set the coordinates of this position as current coordinates, namely, the local coordinate system is synchronous with the actual one.

Generally, these switches are installed at the position of machine zero, i.e. “Back to Machine Zero” equals to the term “Back to Reference Point” in our system. Home switches are also allowed to be installed at other locations.

The principle of returning to REF. point can be divided into two types—with encoder feedback and without encoder feedback.

## 6.1.1 Principle of Returning to Machine Origin (without Encoder Feedback)

The sketch map of returning to machine origin with servo motor is as below (without encoder feedback):

### ◆ Coarse Positioning Stage

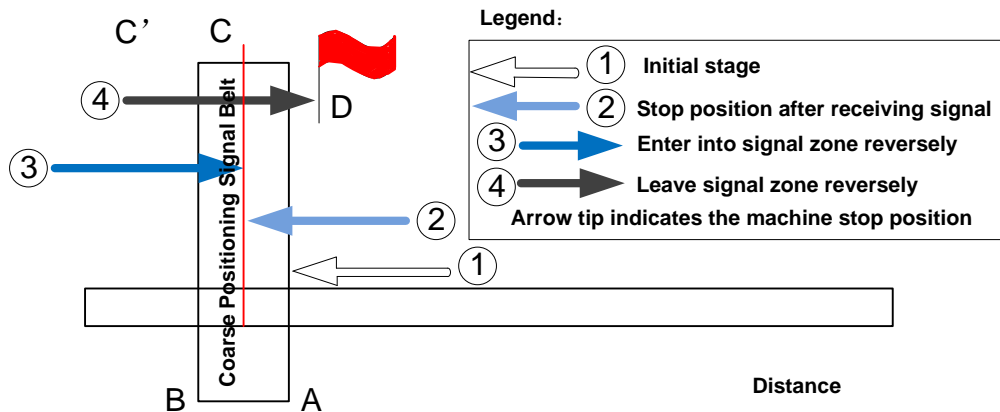

Fig. 6-1 Sketch map of coarse positioning (stopping within the signal belt after receiving REF. point signal)

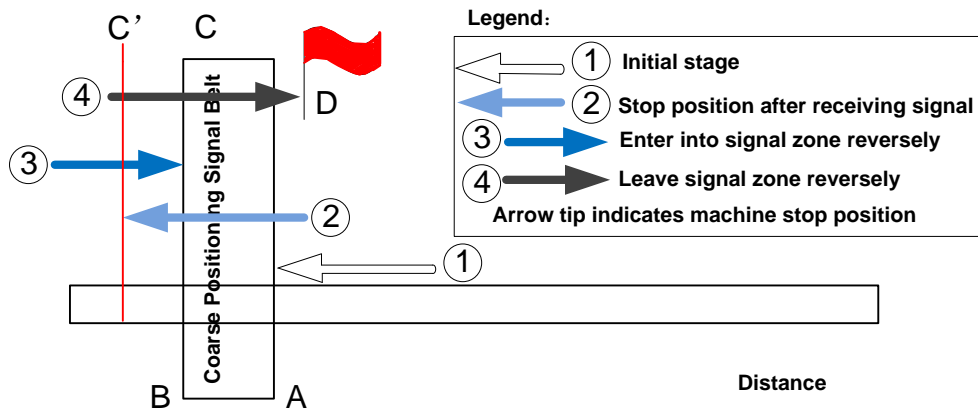

Fig. 6-2 Sketch map of coarse positioning (stopping out of the signal belt after receiving REF. point signal)

- 1) When the machine keeps moving until receiving REF. point signal at place A, it should stop immediately, but it may stop at place C or C' due to time lag and inertia.
- 2) The machine keeps moving reversely at one third of “Home Search Velocity” until receiving REF. point signal (if the machine has stayed in the signal belt in the above step 1, it will make no motion in this step).
- 3) The machine keeps moving reversely at one-tenth of “Home Search Velocity” until the REF. point signal disappears (across the signal belt).

4) The machine halts at the red flag place D at the end of this stage.

◆ **Fine positioning Stage**

Fine positioning, with various methods, is used to make each axis return to machine zero exactly by regarding encoder zero as fine positioning switch in our system, i.e. the axis is locating for machine zero in the motion via detecting encoder zero. Due to one zero signal sent per revolution of encoder, the fine positioning signal is periodic.

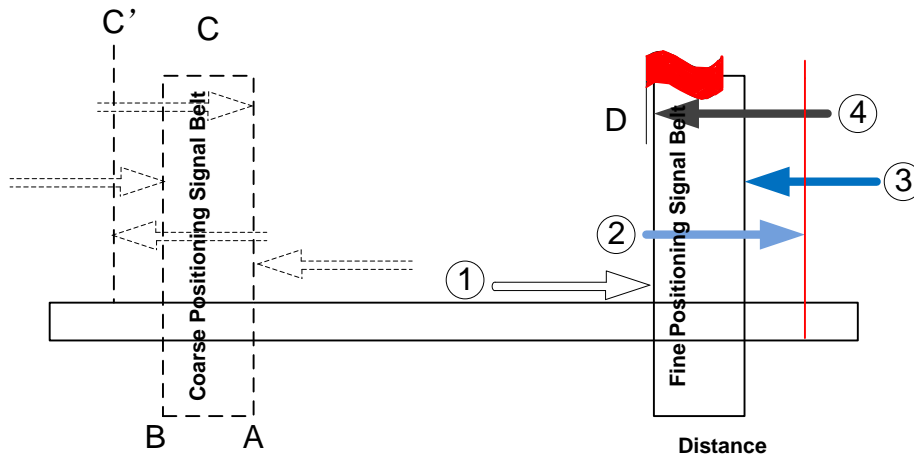

Fig. 6-3 The process of fine positioning

◆ **Retracting Stage**

After finishing the fine positioning stage, the system will execute retracting motion once with recommended retracting distance as half of the screw pitch. The sketch map is shown in Fig. 6-4.

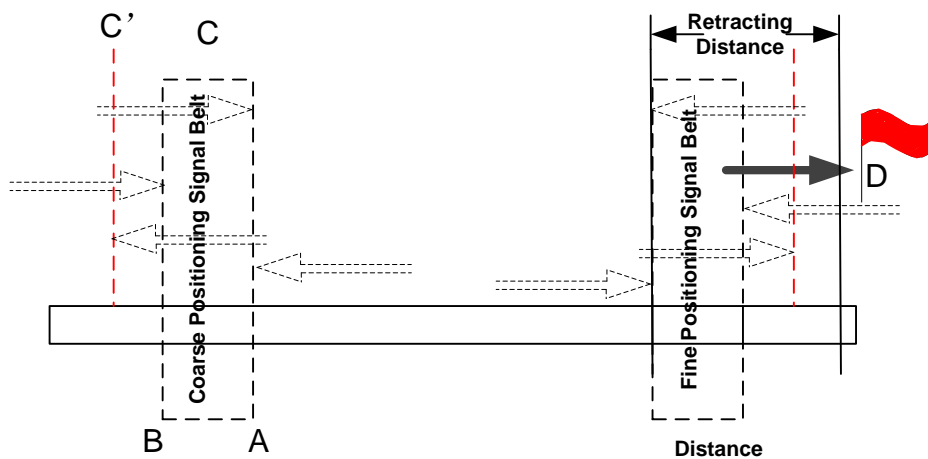

Fig. 6-4 Retracting stage

## 6.1.2 Principle of Returning to Machine Origin (with Encoder Feedback)

With encoder feedback function, the system will execute coarse positioning and fine positioning only once in returning to machine origin. The retracting distance after fine positioning is the actual retracting distance adjusted in terms of actual situation. And the concrete process is as below:

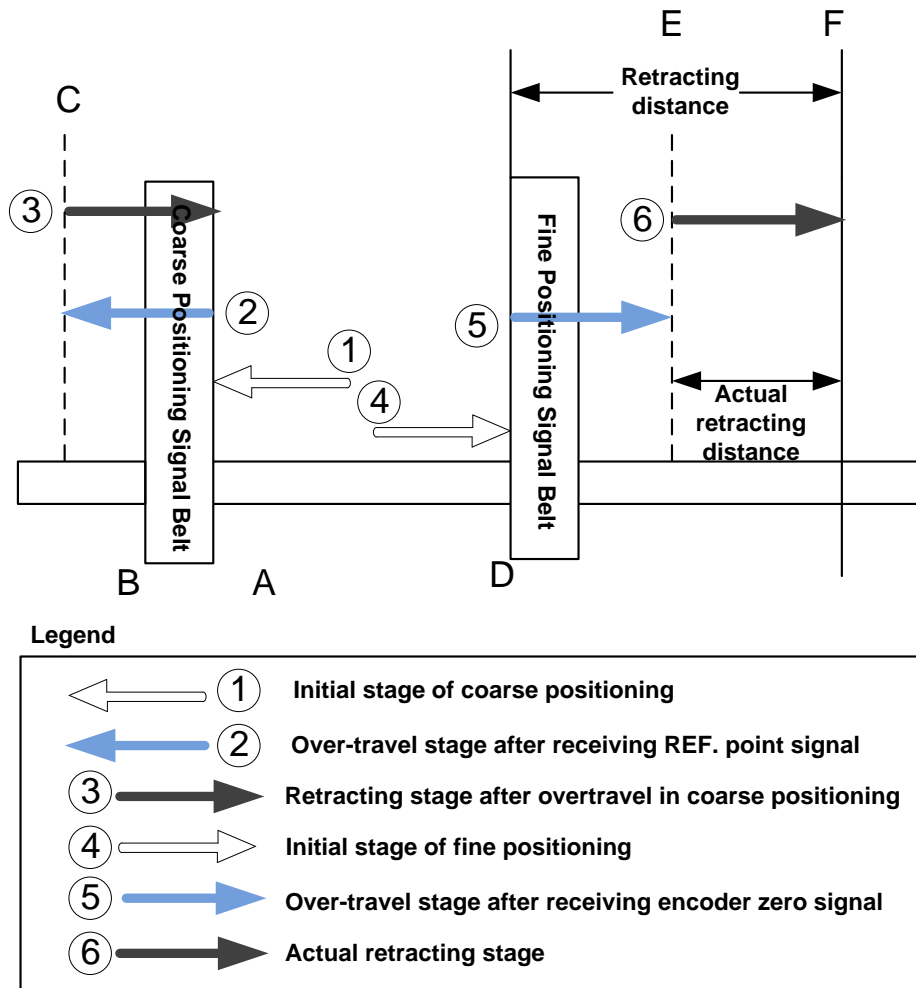

Fig. 6-5 The process of returning to machine origin

- 1) In coarse positioning stage, the machine tool should stop immediately at place “A” when receiving REF. point signal, but it may stop at place “C” due to over-travel caused by inertia and time-lag.
- 2) The machine executes retracting stage of coarse positioning.
- 3) In fine positioning stage, the machine tool moves reversely and should stop at place “D” immediately when receiving encoder zero signal; at the meantime, the feedback data of encoder will be latched, but the machine will generate over-travel and stop at place E due to inertia and time-lag. And the

displacement between encoder zero signal and stop position (i.e. DE) is the across distance of signal deceleration.

- 4) In terms of the retracting distance and across distance calculated, calculate the actual retracting distance, and use this actual distance to make the machine move and stop at place F, keeping it free from the signal source.

## 6.2 Absolute Encoder Function

### 6.2.1 Brief Introduction to Absolute Encoder

Servo motor feeds back the position information with the help of a built-in encoder, which can be divided into two types, incremental encoder and absolute encoder, with differed working principles:

- 1) For servo motor with a built-in incremental encoder, every time the motor rotates a certain angle, the servo motor feeds back a pulse. The driver receives the feedback pulses and calculates the motor rotation degrees.
- 2) For servo motor with a built-in absolute encoder, any position within one revolution of the motor rotation (360 degrees) corresponds to a sure pulse code. In this way, the drivers can secure the motor rotated position through pulse code fed back from the servo motor.

Absolute encoder features recording function of the machine origin, which can greatly decrease non-machining time or preparatory time in real practice, especially for multiple axes situations. That is because with machine origin recording function, returning to the machine origin is not necessary once it has secured during machine setup.

In terms of mechanical structure, positive direction limit, negative direction limit and origin signals for all axes are omitted, improving cost performance and wiring.

### 6.2.2 Hardware Basis of Absolute Encoder

Speaking of hardware, differences between incremental encoder and absolute encoder lie in following aspects:

- 1) Servo motor should be one that supports absolute encoder function. Requirements go as follows, taking YASKAWA motor as an example:

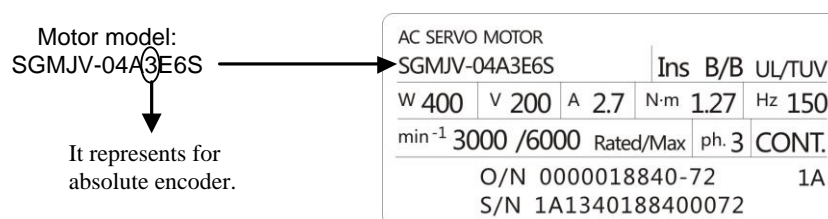

Fig. 6-6 Example of absolute encoder of YASKAWA motor





Please refer to the reference manual to confirm the motor's support for absolute encoder.

- 2) In terms of wiring between the controller with absolute encoder and the driver, pulse positive direction signal DIR+ can be used to control SEN signal. On basis of wiring of general incremental encoder driver, make short-circuit between pin 4 (SEN) and pin 11 (SIGN) to save another pin of +5V and simplify the wiring. See Fig. 6-7 and Fig. 6-8.

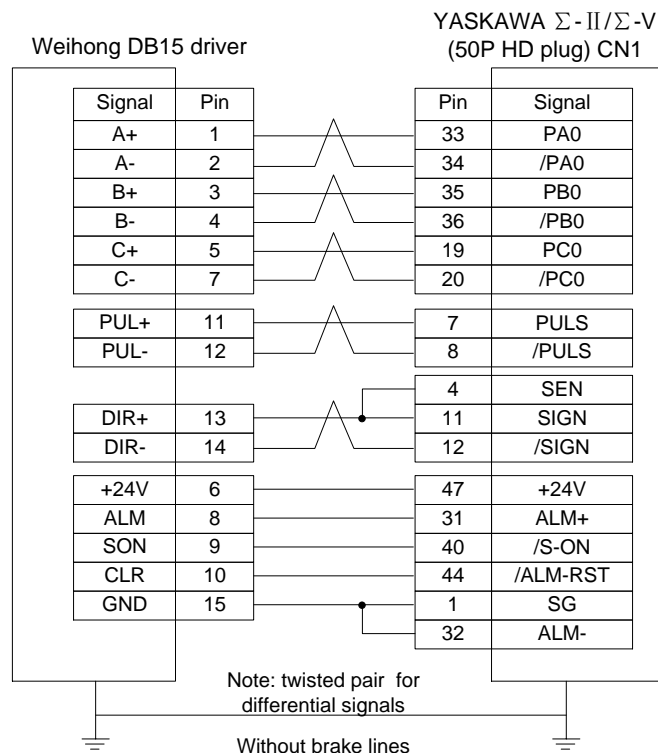

Fig. 6-7 Wiring diagram of absolute encoder (without brake lines)

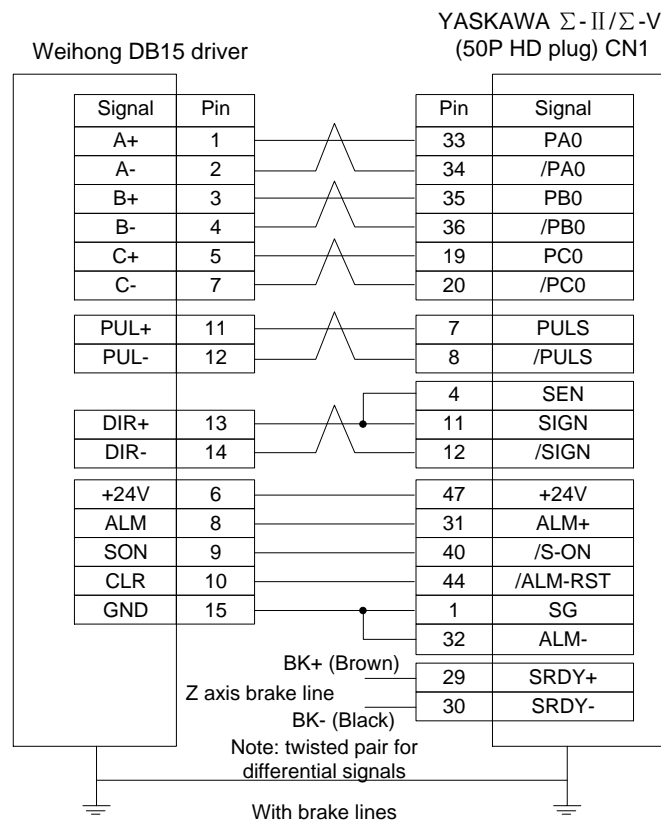

Fig. 6-8 Wiring diagram of absolute encoder (with brake lines)

### 6.2.3 Driver Setup

Parameter Pn002.2 is named “Absolute encoder function selection” for short, whose default value is 0. That is, the absolute encoder function is enabled by default.

◆ **Initialization of absolute encoder**

When the absolute encoder function is enabled, the driver will prompt alarm (A.810) because of absolute positional data error at startup or cable removal of back battery. For this reason, auxiliary setup of Fn008 is in need to make initialization setup of the absolute encoder.

### 6.2.4 How to Use Absolute Encoder Function in the Software

- 1) Set up the machine origin. During first-time setup, absolute encoder position and actual machine position should be interrelated, or machine origin should be secured (once absolute encoder is reset, machine origin should be set again). In later usage, the software only needs to read the actual position of the machine.

Step 1: with **[Manual]** mode activated, move the target axis to the machine origin position;

Step 2: turn to **[Diagnosis]**—**[Position diagnosis]** interface, click button **[Initial setup]** and enter password “NCSTUDIO”.

Step 3: clicks on the target axis. Taking X axis as an example, clicks button **[X datum]**. Then an origin symbol indicating X axis machine origin has been set and secured will appear in front of X axis icon.

Step 4: repeats above operations to set machine origins of the rest axes. If other axes needs to be displayed, clicks button **[Show others]**.

Step 5: restarts the software to make settings effective.

- 2) After datum setup of machine origin is completed, click button **[Export datum]** to export the machine origin position values to target file whose file name is “SaveDatumValue.ini”. In the same way, you can click button **[Import datum]** to load datum file previously saved to the system.

## 6.2.5 Parameter Setup in the Software

### ◆ Parameters related to the absolute encoder

No.	Name	Range	Default	Comment
N11001	Absolute encoder	Yes; No	Yes	Whether to enable the absolute encoder or not.
N11110	Axis Encoder direction	-1;1	1 (Same for 5 axes)	Encoder direction=Axis direction * Logic control direction The driver adopts negative logic. Driver parameter Pn200 is set to 0005, negative logic.
N11160	Pitch	0.001~99999	X~Z: 5mm A/B:360deg	In case of linear rail, sets pitch to the value of lead of screw. In case of gear, set pitch to value of “ $\frac{\text{Lead of screw}}{\text{Mechanical deceleration ratio}}$ ”
N11170	PG division ratio (X4)	1~999999 (pulse/rev)	X~Z: 500 A/B:36000	Encoder feedback pulse number via servo motor dividing per one revolution of the motor. PG division ratio = Encoder division pulse No.×4
N11180	Allowable move distance at power-OFF	0~99999	X~Z: 1mm A/B: 1deg	It stands for the deviation value of the positions at software shutdown of this time and last time. If the difference is larger than this setup value, alarm will occur.
N11303	Wait time at E-stop	0.001~10 (sec)	1	The waiting time for machine complete stop when emergency stop occurs.
N11304	Encoder feedback function	Yes; No	Yes	Whether to enable the encoder feedback function or not.

◆ **Relevant calculation equations**

$$\textcircled{1} \text{ Encoder position} = (\text{Current revolution No.} - \text{Revolution No. at MO}) \times \frac{\text{Pitch}}{\text{Mechanical deceleration ratio}} + \frac{\text{Current Pulses less than one rev.} - \text{Pulses less than one rev. at MO}}{\text{PG division ratio}} \times \frac{\text{Pitch}}{\text{Mechanical deceleration ratio}}$$

(Note: "MO" refers to the machine origin.)

$$\textcircled{2} \text{ Current position} = \text{Machine origin position} + \text{Axis encoder direction} \times \text{Encoder position}$$

$$\textcircled{3} \text{ PG division ratio} = \text{Encoder division pulse No.} \times 4$$

## 6.3 Pulse Equivalent Adjustment

### 6.3.1 Concept of Pulse Equivalent

Pulse equivalent (p): the moving distance of workbench or rotation degree of rotary axis corresponding to one pulse sent by CNC device, the minimum available distance controlled by CNC system as well.

The smaller the pulse equivalent is, the higher the machining precision and surface quality will be. The larger, the faster feedrate will be. Therefore, lower pulse equivalent should be set under the condition of meeting the demand of feedrate. The relationship between max. feedrate and pulse equivalent is as following:

$$\text{Max. Feedrate} = \text{pulse equivalent} \times 60 \times \text{frequency}$$

For example, the hardware frequency of Lambda series CNC system is 1MHz and provided the pulse equivalent is 0.001 mm/p, then:

$$\text{Max. feedrate} = 0.001 \times 60 \times 1000000 = 60\text{m/min}$$

◆ **Mechanical deceleration ratio (m/n)**

Mechanical deceleration ratio (m/n): the ratio of reducer input speed to output speed, equal to the ratio of the teeth number of driven wheel to that of driving wheel. When applied in CNC machines, it specifies the ratio of motor speed to screw speed.

$$\text{Mechanical deceleration ratio} = \frac{\text{reducer input speed}}{\text{reducer output speed}} = \frac{\text{teeth number of driven wheel}}{\text{teeth number of driving wheel}} = \frac{\text{motor speed}}{\text{screw speed}}$$

◆ **Pitch (d)**

Pitch (d): or thread pitch, refers to the distance separating adjacent peaks of the threads on a screw.

The calculation of pulse equivalent varies with different motor systems.

### ◆ Electronic gear ratio (B/A)

The parameter of servo driver (take YASKAWA driver as an example, B is PN202 while A PN203). This ratio represents servo scales up or down the pulse frequency sent by CNC system. When B is larger than A, it means scaling up and vice versa. For example, provided the pulse frequency sent by CNC system is 100Hz, if the numerator of electronic gear ratio (B) is set as 1 while the denominator 2, the actual running speed of servo is 50Hz. On the contrary, if the numerator is set as 2 while denominator 1, the actual running speed turns to 200Hz.

### ◆ Encoder Resolution (F)

Needed pulse number for one circle of servo motor. Please see the servo motor label plate and then refer to the corresponding manual to confirm its encoder resolution.



See section 6.4 for more info of electronic gear ratio and encoder resolution.

## 6.3.2 Calculation of Pulse Equivalent

### ◆ Stepping Motor

In general, firstly set the subdivision and then calculate the pulse equivalent. You can also set the pulse equivalent before calculating subdivision. Their relationship can be shown as:

$$\frac{d}{p} = \frac{360}{\theta} \times x \times \frac{m}{n}$$

Hereinto, p stands for pulse equivalent, x represents subdivision of stepping motor while  $\theta$  refers to stepping angle. Therefore,

$$\text{Pulse equivalent} = \frac{\text{screw pitch}}{\frac{360}{\text{stepping angle}} \times \text{subdivision} \times \text{mechanical deceleration ratio}}$$

For instance, the selected screw lead of X-axis for a certain type of machine tool is 5mm, and the stepping angle of stepping motor is 1.8 degree, with “10” subdivision and motor directly connected with screw by coupling. Thus, the pulse equivalent of X-axis is:

$$\text{Pulse equivalent} = \frac{5\text{mm}}{\frac{360}{1.8} \times 10 \times 1} = 0.0025\text{mm/p}$$

### ◆ Servo Motor

In general, set the default value of pulse equivalent (p) as 0.001mm/p and calculate electronic gear ratio (B/A). Their relationship can be shown as:

$$\text{Electronic gear ratio } \frac{B}{A} = \frac{\text{encoder resolution}}{\frac{\text{screw pitch}}{\text{pulse equivalent}}} \times \text{mechanical deceleration ratio}$$

Namely,  $\frac{B}{A} = \frac{F \times p}{d} \times \frac{m}{n}$

For instance: (an example of YASKAWA servo) screw pitch of a certain type of machine is 5mm, with 17 bit encoder resolution, “0.001mm/p” pulse equivalent and “1:1” deceleration ratio.

$$\text{Electronic gear ratio } \frac{PN202}{PN203} = \frac{2^{17}}{5/0.001} \times 1 = \frac{131072}{5/0.001} \times 1 = \frac{16384}{625}$$



The pulse equivalent of rotary axis refers to the rotation degree of the axis clamping the workpiece corresponding to each pulse. The difference of rotary axis movement from linear axis movement lies in that the screw pitch of rotary axis is 360 degrees. Therefore, in calculating rotary axis pulse equivalent, you just need to replace screw pitch with 360.

## 6.4 Electronic Gear Ratio

### 6.4.1 Electronic Gear

Electronic Gear: assume that the system sends 5000 pulses per revolution of servo motor. When doubling revolutions of servo motor driven by the same amount of pulses is needed, there are two methods available, “set servo parameters” and “addition of mechanical gear between motor spindle and load-spindle”. Using circuit to realize the functions of mechanical gear is called electronic gear, viz. pulse frequency multiplication function.

### 6.4.2 Electronic Gear Functions

Regarding “Electronic Gear”, it refers to a proportional control factor of output displacement to motor when a certain amount of pulses is input. For the “senior device” issuing pulses, it can be regardless of encoder pulse No. and mechanical deceleration ratio in controlling.

Functions of electronic gear: it can set the command unit freely (the displacement of screw corresponding to one pulse sent by the system). Frequency multiplication can be used to amplify the frequency of pulse issued by the system.

Electronic gear ratio= encoder resolution × command unit × mechanical deceleration ratio / screw pitch

Please see the servo motor label plate and then refer to the corresponding driver manual to confirm the encoder resolution of servo motor. Fig. 6-9 is a label plate of YASKAWA SGMSH motor, and the 4th

character of the motor type is the serial encoder specification, so the resolution of this motor is  $2^{17}$ , i.e. 131072.

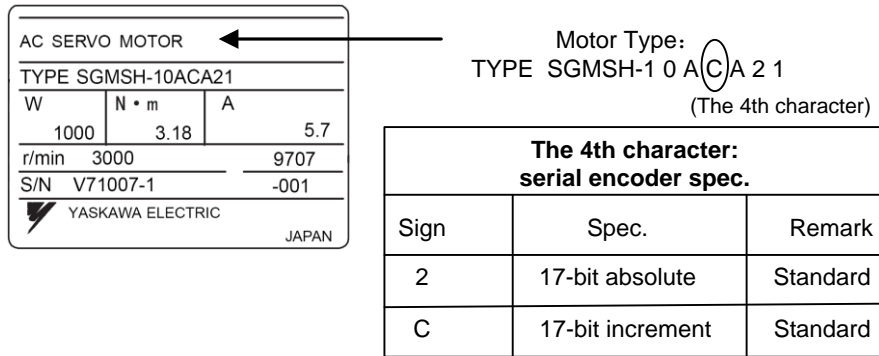

Fig. 6-9 Name plate of servo motor-encoder resolution

For instance: (an example of YASKAWA servo) screw pitch of a certain type of machine is 5mm, with 17 bit encoder resolution, “0.001mm/p” pulse equivalent and “1:1” deceleration ratio.

$$\text{Electronic gear ratio} \frac{PN202}{PN203} = \frac{2^{17}}{5/0.001} \times 1 = \frac{131072}{5/0.001} \times 1 = \frac{16384}{625}$$

The conversion of electronic gear ratio is as shown below.

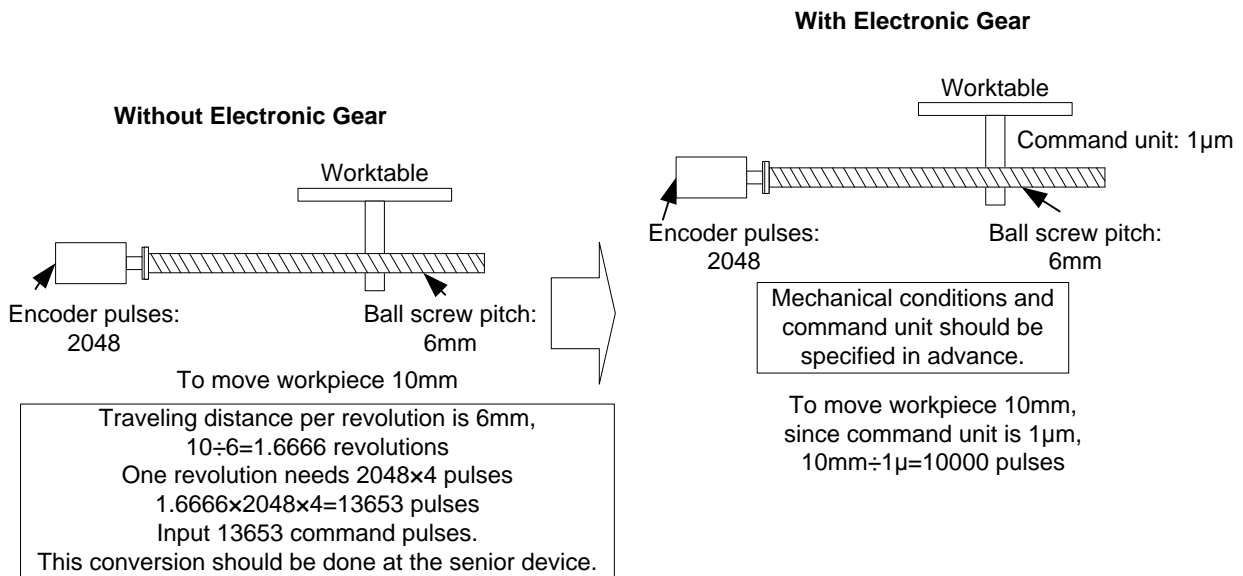

Fig. 6-10 Schematic conversion of electric gear ratio

### 6.4.3 Computing Method of Electric Gear Ratio

The setting of electronic gear ratio should be in accordance with the specification of equipment.

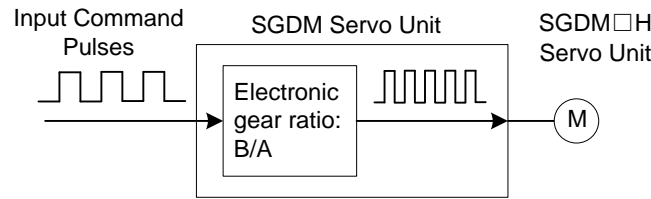

Fig. 6-11 Schematic map of electronic gear ratio function

$$\text{Electronic Gear Ratio } \frac{B}{A} = \frac{Pn202}{Pn203} = \frac{\text{Encoder Pulses} \times 4}{\text{Amount of movement per revolution of bearing axle}} \times \frac{m}{n};$$

$\frac{m}{n}$  is mechanical deceleration ratio.

### 6.4.4 Samples of Electronic Gear Setting

◆ **Sample One**

As screw pitch= 6mm (the screw travels 6mm per revolution of bearing axle), “2048” ( $2^{13}/2^2$ ) pulses will be generated per revolution of servo motor with 13-bit incremental encoder.

Command unit= 0.001mm (the screw moves 0.001mm per pulse generated by the system)

Amount of movement per revolution of bearing axle= 6mm/0.001mm=6000

**Ball Screw**

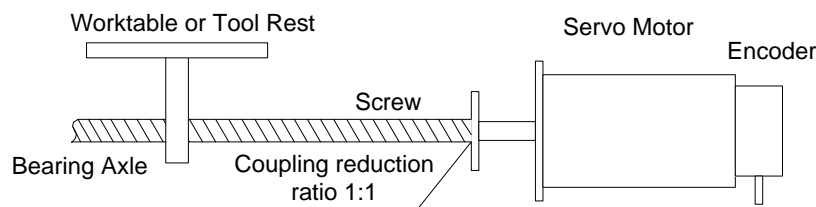

Fig. 6-12 Servo motor and screw sharing same axle (without reduction gearbox)

Servo motor and screw are sharing the same axle (without reduction gearbox), and one revolution of motor will lead to one rotation of screw.

$$\text{Electronic Gear Ratio } \frac{B}{A} = \frac{2048 \times 4}{6000} \times \frac{1}{1} = \frac{8192}{6000} = \frac{Pn202}{Pn203}$$

(Note: for YASKAWA servo, “4” should be multiplied by the numerator.)

Table 6-1 Parameters setting value

Parameter	PN202	PN203
Setting Value	8192	6000



◆ Sample Two

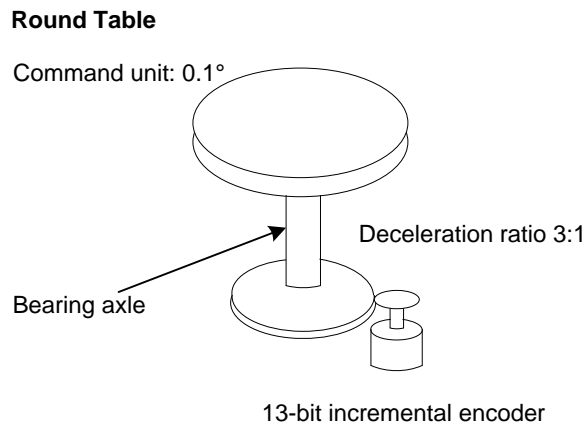

Fig. 6-13 Sample of round table

Pulses generated per revolution of motor= $2^{13}/2^2=2048$

Angle of rotation per revolution= $360^\circ$

Command unit= $0.1^\circ$

Amount of movement per revolution of bearing axle= $360^\circ / 0.1^\circ=3600$

$$\text{Electronic Gear Ratio } \frac{B}{A} = \frac{2048 \times 4}{3600} \times \frac{3}{1} = \frac{\text{Pn202}}{\text{Pn203}}$$

Table 6-2 Parameters setting value

Parameter	PN202	PN203
Setting Value	24576	3600

◆ Sample Three

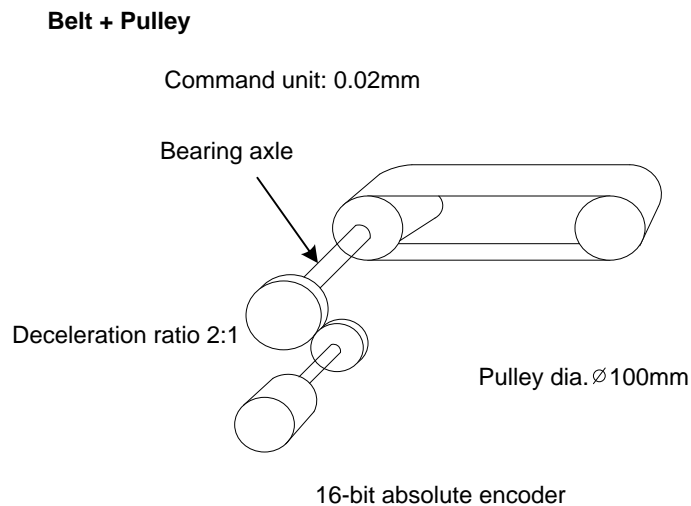

Fig. 6-14 Sample of belt and pulley

Pulses generated per revolution of motor= $2^{16}/2^2=16384$

Pulley diameter= $100\text{mm}$

Command unit= $0.02\text{mm}$

Amount of movement per revolution of bearing axle=  $3.14 \times 100\text{mm} / 0.02\text{mm} = 15700$

$$\text{Electronic Gear Ratio} \frac{B}{A} = \frac{16384 \times 4}{15700} \times \frac{2}{1} = \frac{\text{Pn202}}{\text{Pn203}}$$



If the calculation result is out of setting range, both the numerator and denominator should be divided by their common divisor.

Table 6-3 Parameters setting value

Parameter	PN202	PN203
Setting Value	131072	15700

# 7 Software License Agreement

---

## **Important—Read Carefully before Using This Product:**

The term “Software Product” includes all copies of the licensed software and its documentation. This license agreement is a legal agreement between You (either an individual, a legal entity or any affiliated companies or other entities) and Weihong Electronic Technology Co., Ltd. (hereinafter referred to as Weihong Company). By installing, copying, or otherwise using the Software Product, you agree to be bound by the terms and conditions of this license. Unless otherwise stated in this agreement, you shall not use, copy, revise, rent, or transfer the Software product or any part of the Software Product for any other purposes.

## **Description of Further Rights and Restrictions:**

1. You may install for use one copy of the Software Product on a single machine;
2. You may make a copy of the Software Product for archive or backup purposes and the copy is to be used on this machine only;
3. You may transfer the Software Product and the license agreement to a third party, provided that the third party accepts the terms and conditions stated in this agreement, with prior express permission from Weihong Company;
4. When transfer confirmed, you shall transfer all the copies of the original documents and the supplementary documents to the third party or destroy all the copies un-transferred.
5. You can use the Software Product on a network server or intranet server only if it is stipulated in explicit terms that you are allowed to use the Software Product on a network server or intranet server, or you have purchased license for each node and terminal using the Software Product;
6. You may NOT sublicense, assign or transfer the license agreement;
7. You may NOT or direct any third party to reverse engineer, decompile or disassemble the Software Product;
8. You may NOT copy or transfer the Software Product or any part of the Software Product unless otherwise expressly stated in this agreement;
9. The license agreement shall be terminated automatically upon you transfer the Software Product or copies of all or part of the Software Product to a third party.

## **Intellectual Property Rights Notice:**

The Software Product and all intellectual property rights therein (including but not limited to any all copyrights, patents, trademarks, and publicity rights) are owned by Weihong Company. The Software Product is protected for Weihong Company on the basis of copyright law and international treaty provisions as well as on the basis of other laws and agreements regarding intellectual property. You are not allowed to remove the copyright statement made in the Software Product, and guarantee that you shall copy the copyright statement in all copies of the Software Product or of any part of the Software

Product. You are obliged to stop any form of illegal copying of the Software Product and accompanying materials.

**After-sales Guarantee:**

Weihong Company guarantees that for 90 days from the date of shipment the software carrier will be free from defects in materials and workmanship. When such a defect has been confirmed, our only responsibility is to replace the software carrier. This remedy is your exclusive remedy. This after-sales guarantee is invalid for any carrier defect caused by accidents, abuses or maloperation. The replaced software carrier enjoys the remaining guarantee time of the original software carrier or of a 30-day guarantee time, whichever is longer.

Except as the after-sales guarantee made above, the Software Product does not enjoy any other form of after-sale guarantee.

**Limitation of Liability:**

The above guarantee, whether made explicitly or by implication, constitutes the entire contents of the guarantee, including guarantee for the commerciality and applicability of special application aim. Whether you follow other terms in this agreement or not, Weihong Company, as well as its agents and sales staff, will not be responsible for any profits loss, availability loss, business break-off or any forms of indirect, special, accidental or inevitable damage or claim made by any third party, generated from the using of the Software Product, even if Weihong Company has been informed of the possible occurrence of such events in advance.

**Termination:**

This license may be terminated by Weihong Company at any time once you violate any terms or conditions made in this agreement. Once the license is terminated, you are obliged to destroy all the copies of the Software Product or return them to Weihong Company.

**Applicable Law:**

Copyright Law, Regulations for the Protection of Computer Software, Patent Law and other relevant laws and regulations.

Now, we affirm that you have already read through this agreement and understood it thoroughly and agreed to comply with all of the terms and conditions of this agreement strictly.

Weihong Electronic Technology Co., Ltd.