

# Product Introduction

VT310E is a position sensor controller based on EtherCAT communication. The preamplifier collects the capacitance information between the cutting head nozzle and the workpiece, and then analyzes and processes it through the control box. It can achieve real-time and precise positioning of position and height in high-speed motion.

## System Connection

The system connection diagram is as follows:

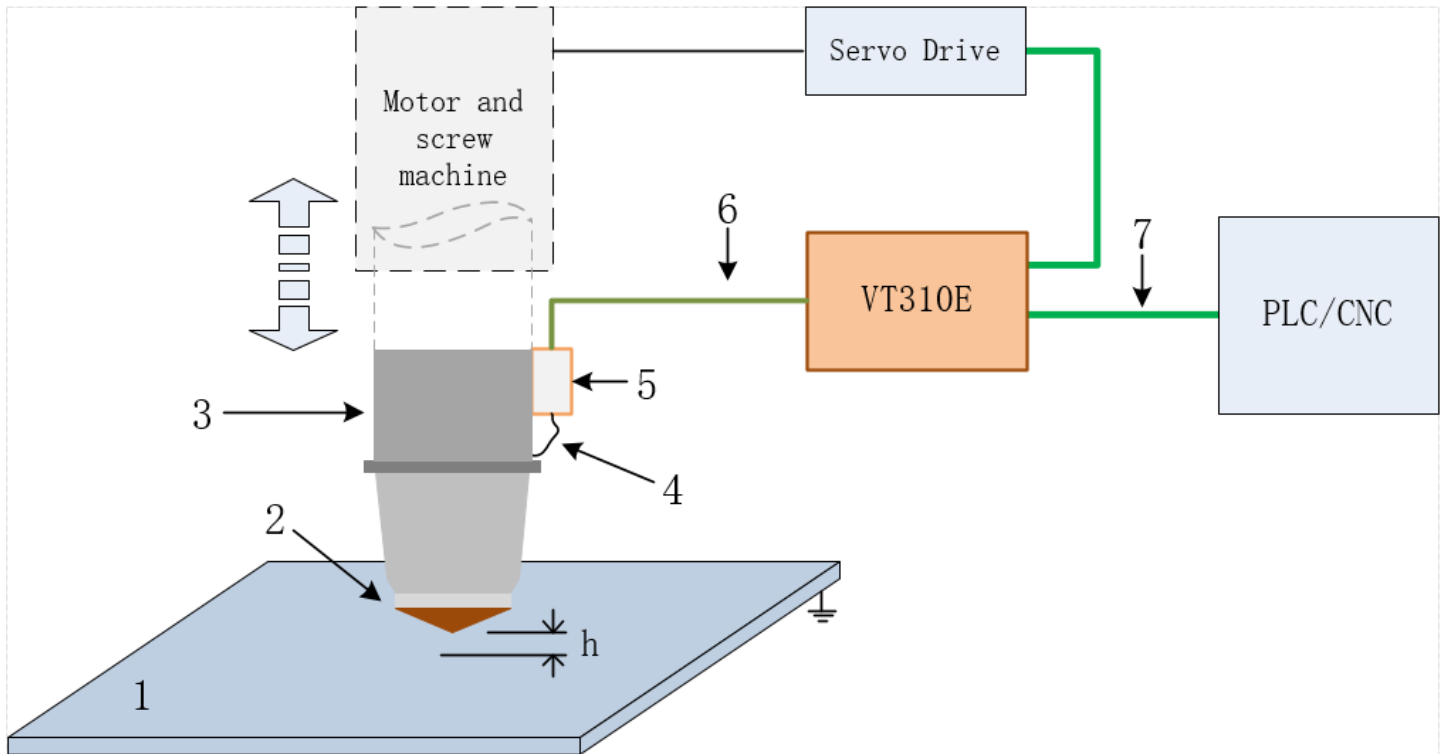

1.Workpiece to be machined 2.Cutting head nozzle 3.Cutting head body 4.RF cable 5.Precapacitor amplifier SE001 6.M16 three-core aviation cable (sensor signal cable) 7.EtherCAT connection cable h.Distance between nozzle and workpiece

Standard components include:

NAME	QUANTITY	STANDARD MODEL	OPTIONAL SPECIFICATION
Control box	1	VT310E	-
Precapacitor amplifier	1	SE001	-
RF cable	1	SMA/JW-SMA/J 200mm	-
M16 three-core aviation plug drag chain cable	1	5000mm	<input type="checkbox"/> 15000mm <input type="checkbox"/> 20000mm <input type="checkbox"/> 30000mm

In order to build a complete system, the client also needs to configure:

- A controller with EtherCAT master (such as PLC/CNC, communicating with VT310E)
- A set of servo drives and motors that control follow-up axis motion (motion controlled by PLC/CNC)
- A set of cutting heads (can be assembled with SE001)

# VT310E

## Product Appearance and Interface

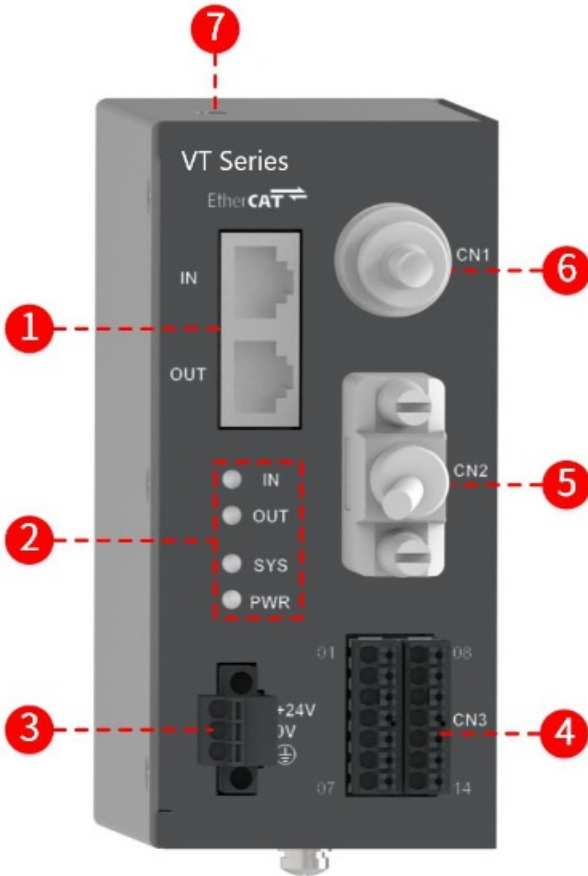

1.EtherCAT interface 2. Indicator light 3. Power interface \*4. Input/output interface \*5.Servo drive interface 6.Precapacitor amplifier interface 7.USB communication interface

\*Note: 4 and 5 are used by other models of this system and are not supported by VT310E.

The interface functions are shown in the following table. For details, please see [Interface Description](#).

NAME	FUNCTION
EtherCAT interface	Used for EtherCAT communication, transmission rate 100Mbps. IN is connected to the up EtherCAT master station, and OUT is connected to the next EtherCAT slave machine.
Indicator light	Used to indicate controller status. <b>PWR</b> is the power indicator light, indicating whether the power supply is normal. <b>SYS</b> is the system indicator light, which can identify different states: □ Flashing frequency 0.33Hz: EtherCAT is in non-OP state; □ Flashing frequency 2Hz: EtherCAT is in OP state and can communicate; □ Flashing frequency 10Hz: Hardware self-check failed; □ Flashing frequency of 1Hz and 3Hz alternately: XML (ESI) file reading failed; <b>IN</b> and <b>OUT</b> are EtherCAT indicators. If they are on, they are connected. If they flash, they are communicating with each other.
Power interface	For connecting to 24VDC power supply.
Precapacitor amplifier interface	For connecting precapacitor amplifier SE001.

NAME	FUNCTION
USB communication interface	Connect to the host and communicate with the debugging software iFollow for realizing internal debugging, firmware upgrade and other functions.

### Installation Dimension

The front view and side view are as follows (unit: mm):

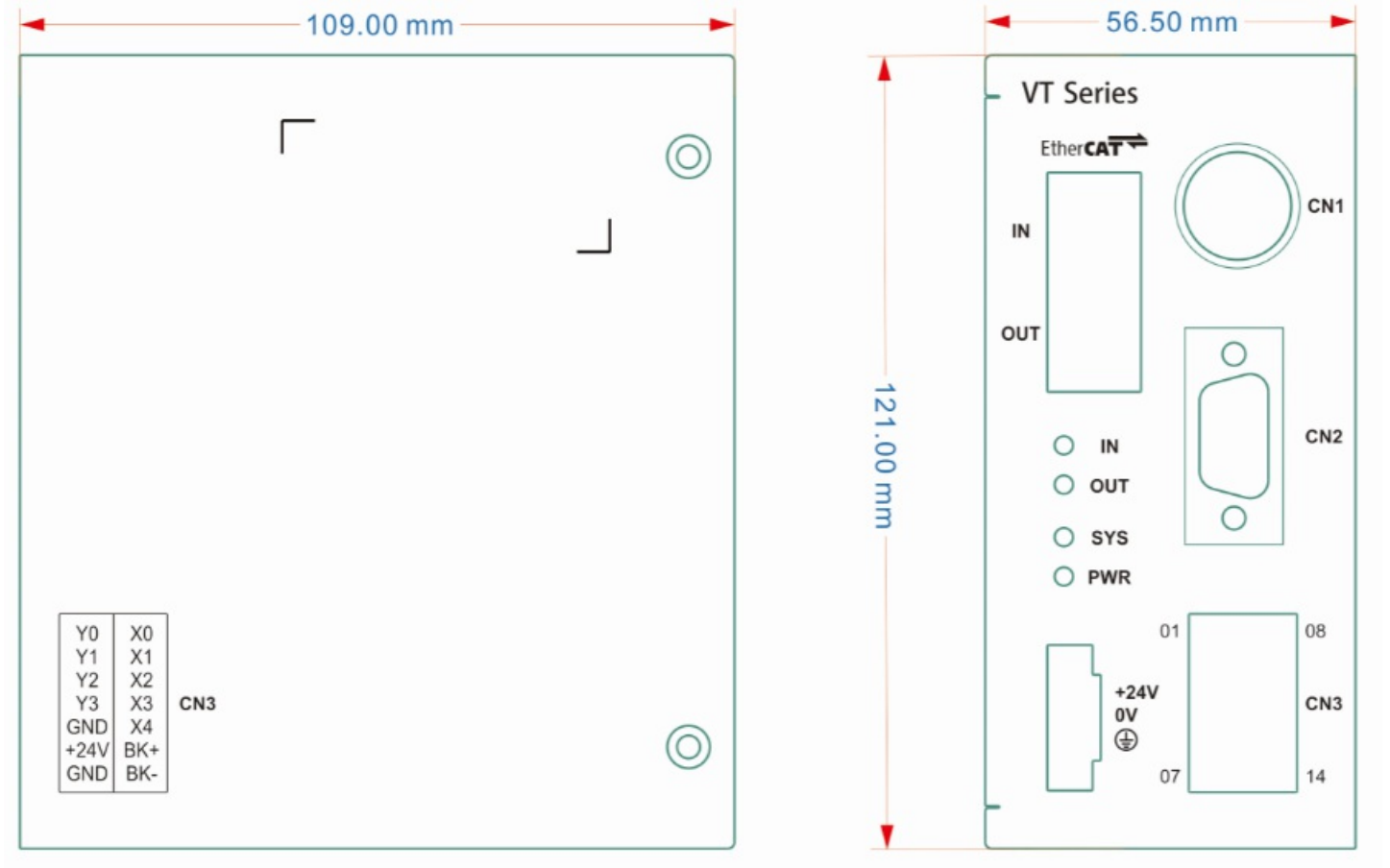

Installation method:

The VT310E structure is pre-installed with DIN rail fixed buckles on the back, which can install 35 \* 7.5mm (width \* depth) rail.

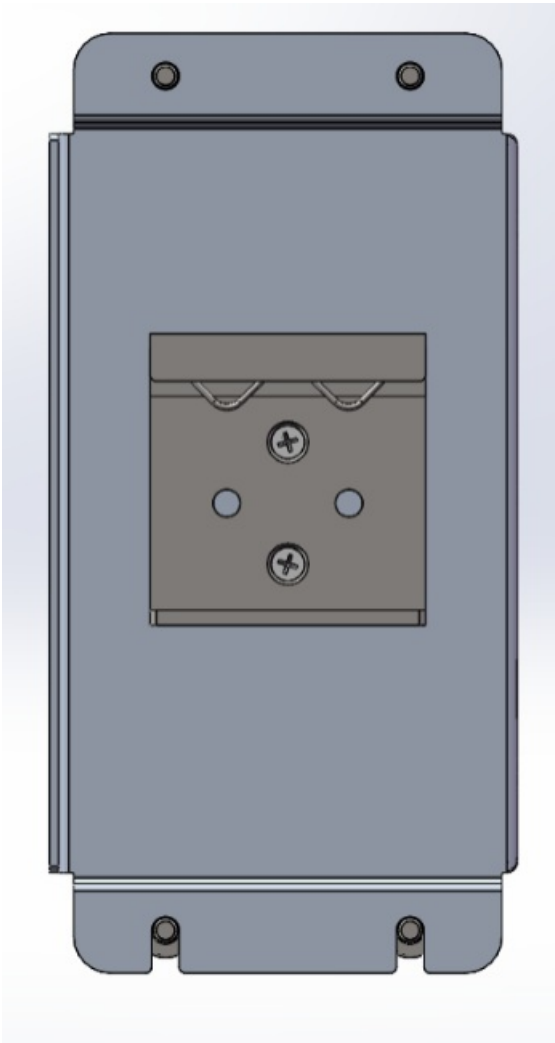

## Preamplifier SE001

### Product Appearance and Interface

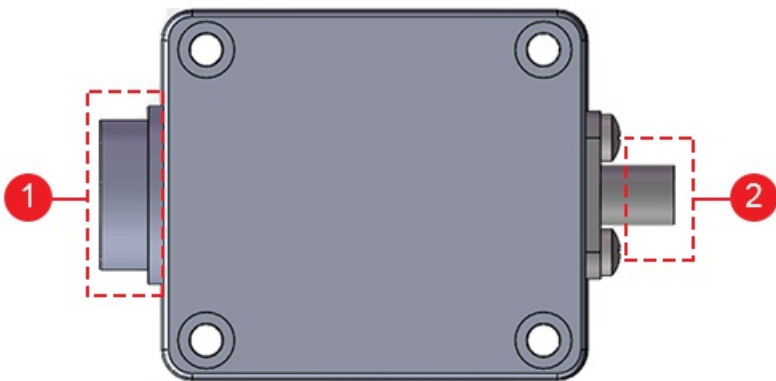

1.M16 aviation cable interface 2.SMA RF cable interface

### Installation Dimension

SE001 front view and rear view (dimension drawing) are as follows (unit: mm):

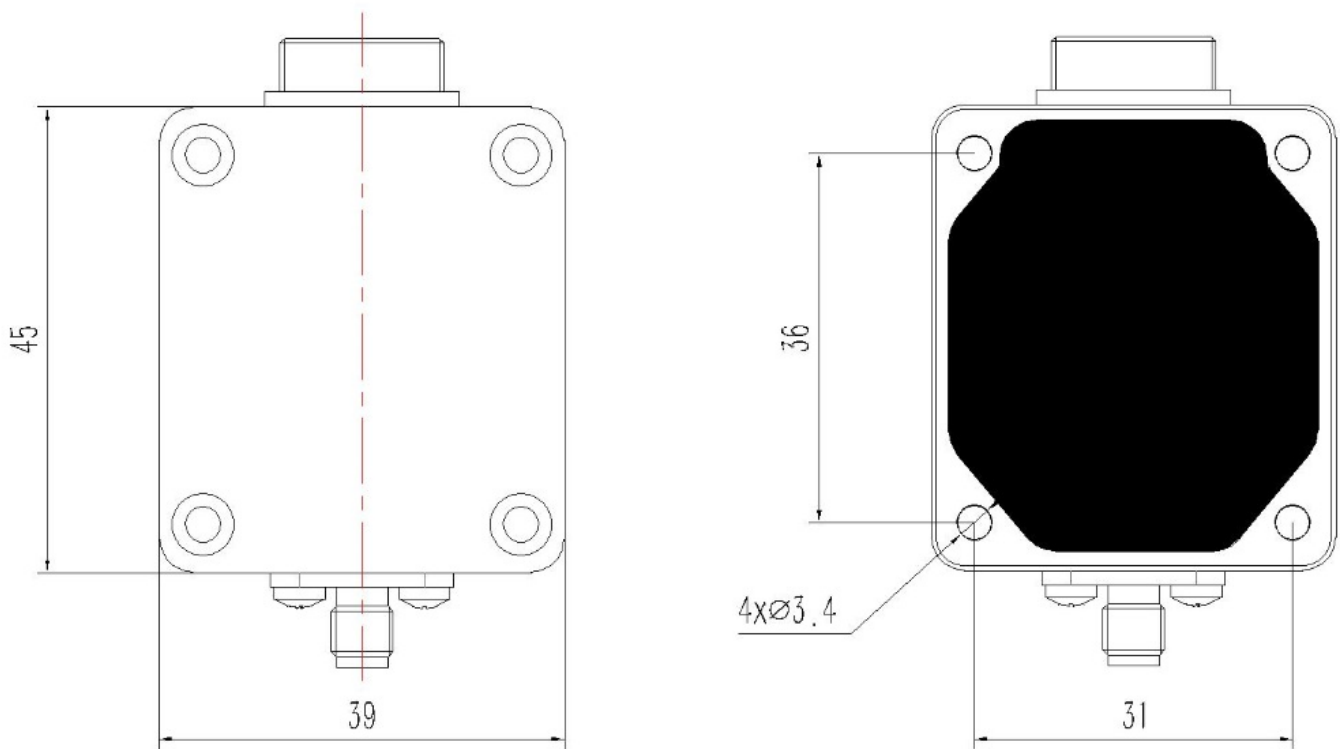

## Features

- Support 16-point capacitance calibration
  - Calibration height can be flexibly set by SDO
  - Active identifies various anomalies in the calibration process (such as excessive fluctuations in capacitance values or wrong trends, etc.)
- Support nozzle loss point calibration, can realize detect real-time alarm for over-range and nozzle loss
- According to calibration data and real-time capacitance sampling value, accurate calculation and feedback of current height information
- Open multiple detection threshold parameters for users to set, which can be compatible with different application scenario needs
- Provide system running status and fault information to facilitate diagnosis and analysis
  - The SYS indicator light on the panel can quickly identify whether the system is running normally
  - Specific internal running status (calibration/measurement/debugging, etc.) can be read through SDO
  - Alarm information can be obtained through PDO combination
- Support firmware online update

## Specification Parameter

SPECIFICATION NAME	PARAMETER VALUE
Supply voltage	24VDC ± 10%
Measurement range	0.1 ~ 25mm (the measured maximum value is limited by calibration height)
Control cycle	1ms

<b>SPECIFICATION NAME</b>	<b>PARAMETER VALUE</b>
Working temperature	0°C~55°C
Working humidity	10%~95% (no condensation water)
Storage temperature	-40°C~70°C

# Installation Precautions

**When connecting VT310E, the requirements for the connecting cable are as follows:**

- The power supply line can use unshielded three-core wire, and the PE wire needs to be connected to the ground wire of the machine tool control cabinet.
- EtherCAT transmission line require shielded network cable.
- It is recommended to use a minimum  $\varphi 0.5\text{mm}^2$  specification for the power supply line.
- It is recommended to use a minimum size of  $\varphi 1.5\text{mm}^2$  specification for the ground wire.

**In order to ensure the stability and accuracy of system measurement and comply with the EMS and EMI characteristics specified by CE standards, the following basic rules must be followed:**

- The metal structural parts of the machine tool and the shell of SE001 are negative poles of the measured capacitance. It is necessary to ensure that the shell of SE001 and the metal structural parts of the machine tool are well connected.
- Ensure there is a good electrical connection (DC resistance less than  $10\Omega$ ) between the VT310E shell (ground terminal) and the machine tool control cabinet.
- Ensure a low impedance connection between the VT310E and the precapacitor amplifier case (DC resistance less than  $10\Omega$ ).
- Ensure that the machine tool control cabinet is star grounded.
- For safety reasons, add an additional ground wire between the PE terminal of the VT310E power supply and the star ground point of the machine tool control cabinet.
- Analog signal line, digital signal line, and power line should be routed separately to avoid interference and abnormal operation of the controller.

# Interface Description

## Power Interface

The power interface is a three-core terminal, and each pin is defined as follows:

NAME	DESCRIPTION
+24V	24 V or output connected to DC power supply
0V	Connect to 0V/COM or negative terminal of DC power supply
PE	Connect the ground wire of the machine tool <b>Note:</b> Please do not connect the PE terminal to the neutral wire of the power supply line.

## EtherCAT Interface

The EtherCAT interface contains two Ethernet ports, IN and OUT.

NAME	DESCRIPTION
IN	Connect to the OUT of the EtherCAT master station or upper-level slave station
OUT	Connect the IN of the next-level EtherCAT slave station

## Capacitor Amplifier Interface

The sensor M16 interface is shown follows.

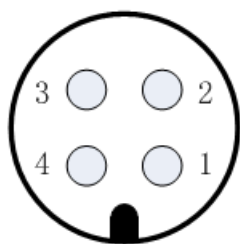

For the pin number definition of the sensor M16 interface, see the follows:

PIN NO.	DEFINITION
1	+5 V: power supply
2	GND: power ground
3	SIG: signal
4	PE: shield layer

## USB Interface

Connect to a computer with the VT310E debugging software iFollow installed to update the firmware.



# Function Description

## System Status Indication

There are 5 states during the operation of VT310E. By reading the combined state of the four PDOs FAR/ COLLISION/ READY/ POS\_REACHED (index number 0x1A00), the current working state can be viewed.

The corresponding relationship between each status is as follows:

STATUS TYPE	FAR	COLLISION	READY	POS_REACHED	STATUS DESCRIPTION
INITIALIZATION	0	0	0	0	Initial state
NORMAL	0	0	1	0	Normal running status
FAR	1	0	1	0	Out of measurement range, but not reaching capacitance threshold for nozzle loss alarm
TIP TOUCH	0	1	0	0	Cutting head touch part
NOZZLE LOST	1	1	0	1	Cutting head nozzle is lost
ERROR	0	1	0	0	Calibration process error

### NOTE

- When there is no calibration data inside the VT310E, it will continue to be in the INITIALIZATION state;
- When the calibration data of VT310E is normal, it will automatically switch from INITIALIZATION to NORMAL state;
- FAR, TIP TOUCH, NOZZLE LOST, and ERROR are alarm prompts.

## 16-point Capacitance Calibration

### Function Introduction

Before starting height measurement, the system needs to perform position calibration in advance and establish a correspondence table between height and capacitance. Through the control sequence with the host, the host controls the specified PDO to trigger the calibration. VT310E sequentially samples the capacitance of 16 mark points and the capacitance of the nozzle loss point within the calibration range to complete the capacitance calibration and the nozzle loss point calibration.

### Associated Parameter

Before starting calibration, the following parameter setting need to be completed:

- [Calibrated Length \(Meas\\_mm\)](#)
- [Capacitance Sampling Allowable Error \(Tolerant CapErr\)](#)

### Calibration Control Sequence

Associated PDO description:

HOST CONTROL PDO	FUNCTION DESCRIPTION	VT310E CONTROL PDO	FUNCTION DESCRIPTION

HOST CONTROL PDO	FUNCTION DESCRIPTION	VT310E CONTROL PDO	FUNCTION DESCRIPTION
CAL_REQUEST	Rising edge: start calibration Falling edge: end calibration	READY	0: The system is ready and can start calibration 1: The system is not ready and cannot be calibrated
STROBE	0: Not reaching the calibration point 1: Reach the calibration point	COLLISION	0: Not touch part 1: Touch part
		POS.REACHED	0: Capacitance collection at the current calibration point is successful 1: The calibration point capacitance is not collected successfully

The calibration control sequence diagram is as follows:

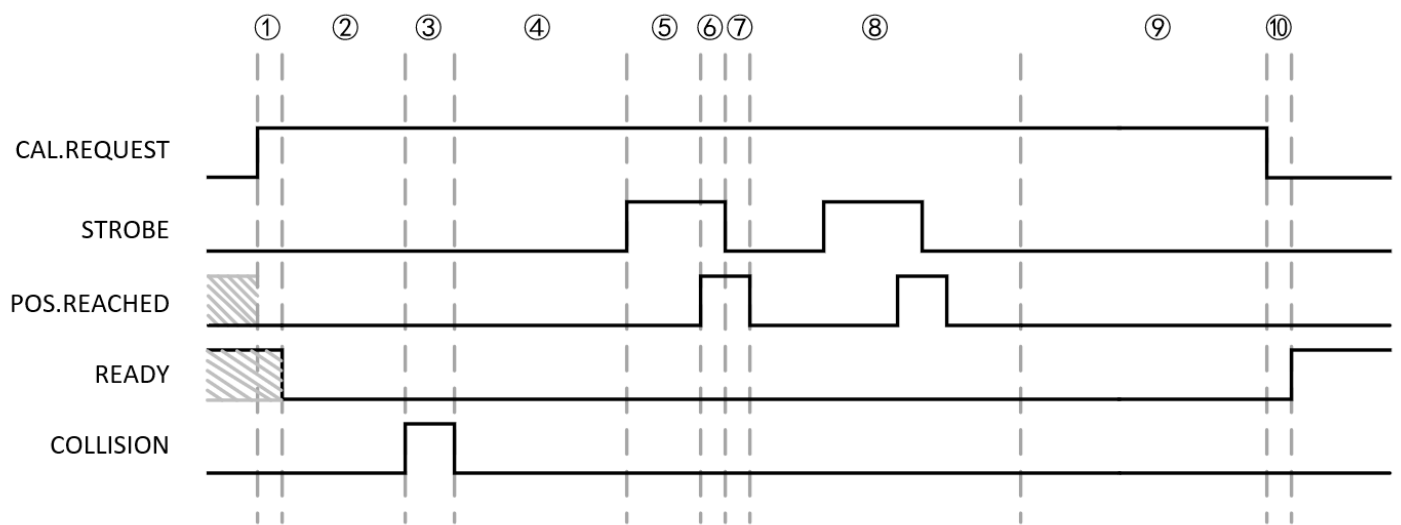

1. The host sends CAL\_REQUEST as **1** to request to start calibration. VT310E controls READY to **0** within 10ms after receiving CAL\_REQUEST as **1**, indicating that the system is ready and can start calibration.
2. The host controls the drive to move toward the workpiece. When the cutting head touch part is detected, VT310E controls COLLISION to **1**, indicating the touch part status.
3. After the host detects that COLLISION is **1**, it controls the cutting head to move away from the workpiece. When VT310E controls COLLISION to **0** within 5ms after the cutting head leaves the workpiece, it means canceling the touch part state.
4. The host controls the cutting head to move to the first position point of the 16-point calibration, and then sends STROBE as **1**, and it means reaches the calibration point.
5. After receiving STROBE as **1**, VT310E starts sampling the capacitance value. When the capacitance fluctuation value is detected to be less than the set capacitance sampling tolerance, it is determined that the capacitance value is valid, the current mark point is successfully collected, and POS\_REACHED is controlled to **1**.
6. After the host detects that POS\_REACHED is **1**, it sends STROBE as **0**.
7. After VT310E detects that STROBE is **0**, it controls POS\_REACHED to **0** within 1ms, which means that the current point collection is completed and subsequent points can be calibrated.
8. Execute steps **4~7** in a loop to calibrate the remaining 15 points.
9. The host controls the cutting head to move to a position where the distance from the workpiece is greater than 30mm,

maintains a static state for more than 200ms, and then sends CAL\_REQUEST as 0 to request to exit the calibration state. VT310E now completes the calibration process of the nozzle loss point.

10. VT310E controls the READY signal to output a high level within 10ms after receiving the low level of the CAL\_REQUEST signal and enters the idle state at the same time.

**⚠ CAUTION**

- The two steps 9 and 10 are to calibrate the point where the nozzle is lost and must be carried out during the calibration process. Failure to perform these two steps will result in calibration failure.
- If the calibration process is interrupted (failed), VT310E will control TxPDO\_COLLISION to 1.
- If the calibration process is interrupted (failed), the 16-point capacitance calibration needs to be re-started from step 1.
- If there is calibration data stored in the VT310E before the calibration starts, the previous calibration data will still be used in the measurement mode after the calibration is interrupted (failed).

**16-point Calibration Reference Distance**

The positions of the 16 reference points during the calibration process are pre-determined by the VT310E. The host needs to control the driver to run to the specified position in sequence.

Taking the calibration length of 20mm as an example, the height requirements of each reference point are as follows:

REFERENCE POINT SERIAL NUMBER	HEIGHT FROM PLATE (MM)
1	20
2	16
3	14
4	12
5	10
6	8
7	6
8	5
9	4
10	3.6
11	3
12	2.4
13	2
14	1.4
15	1

REFERENCE POINT SERIAL NUMBER	HEIGHT FROM PLATE (MM)
16	0.4
Nozzle lost point	>30

#### **NOTE**

- After resetting the calibration length, the height from plate of the 16-point calibration must be adjusted proportionally. If the calibration length is set to 10mm, the height from plate of calibration point 1 is 10mm, the height from plate of calibration point 2 is 8mm, and so on.
- No matter how much the calibration length is set, the height from plate of the nozzle loss point must be >30mm.

## Nozzle Loss Point Capacitance Calibration

### Function Introduction

The nozzle loss point capacitance calibration function can be calibrated separately in addition to being executed during the 16-point capacitance calibration process.

### Associated Parameter

- [Capacitance Sampling Allowable Error \(Tolerant CapErr\)](#)

### Control Sequence

Associated PDO description:

HOST CONTROL PDO	FUNCTION DESCRIPTION	VT310E CONTROL PDO	FUNCTION DESCRIPTION
NL_STROBE	Rising edge: start calibration Falling edge: end calibration	READY	0: The system is ready and can start calibration 1: The system is not ready and cannot be calibrated

Calibration preconditions:

- The system is in NORMAL state

Control sequence requirements:

1. The host controls the cutting head to move to the nozzle loss calibration point (greater than 30mm), sends NL STROBE as 1 and maintains it for at least 200ms, and then sets it to 0.
2. When VT310E receives NL STROBE as 1, it starts sampling the capacitance value. After detecting that NL STROBE is 0, record the average capacitance value for 200ms as the nozzle loss point capacitance, and set the READY signal to 1.
3. After completing the calibration, VT310E automatically enters the measurement mode.

#### **NOTE**

- When calibrating the capacitance of the nozzle loss point, keep the cutting head still at a position greater than 30mm.
- The NL STROBE signal is set to 1 for at least 200ms.
- VT310E will analyze the collected capacitance value and determine that the capacitance is valid only when the capacitance fluctuation value is less than the capacitance sampling tolerance.

## Height Measurement

## Function Description

After completing the 16-point capacitance calibration, VT310E can enter the NORMAL state for real-time height measurement. Specifically includes the following functions:

- According to the calibration data and the current capacitance sampling value, real-time feedback of height data through PDO (DAC)
- When the cutting head touch part is detected, exceeds the calibration range, and the nozzle is lost, the system status is switched and an alarm is prompted. For details, please see [System Status Indication](#).

### NOTE

In the touch part state, the DAC value is 0; in the over-range/nozzle loss state, the DAC value is 65535.

Real-time altitude data is calculated linearly based on the calibration curve though. The corresponding relationship between height from plate and height data output (DAC) value is as follows:

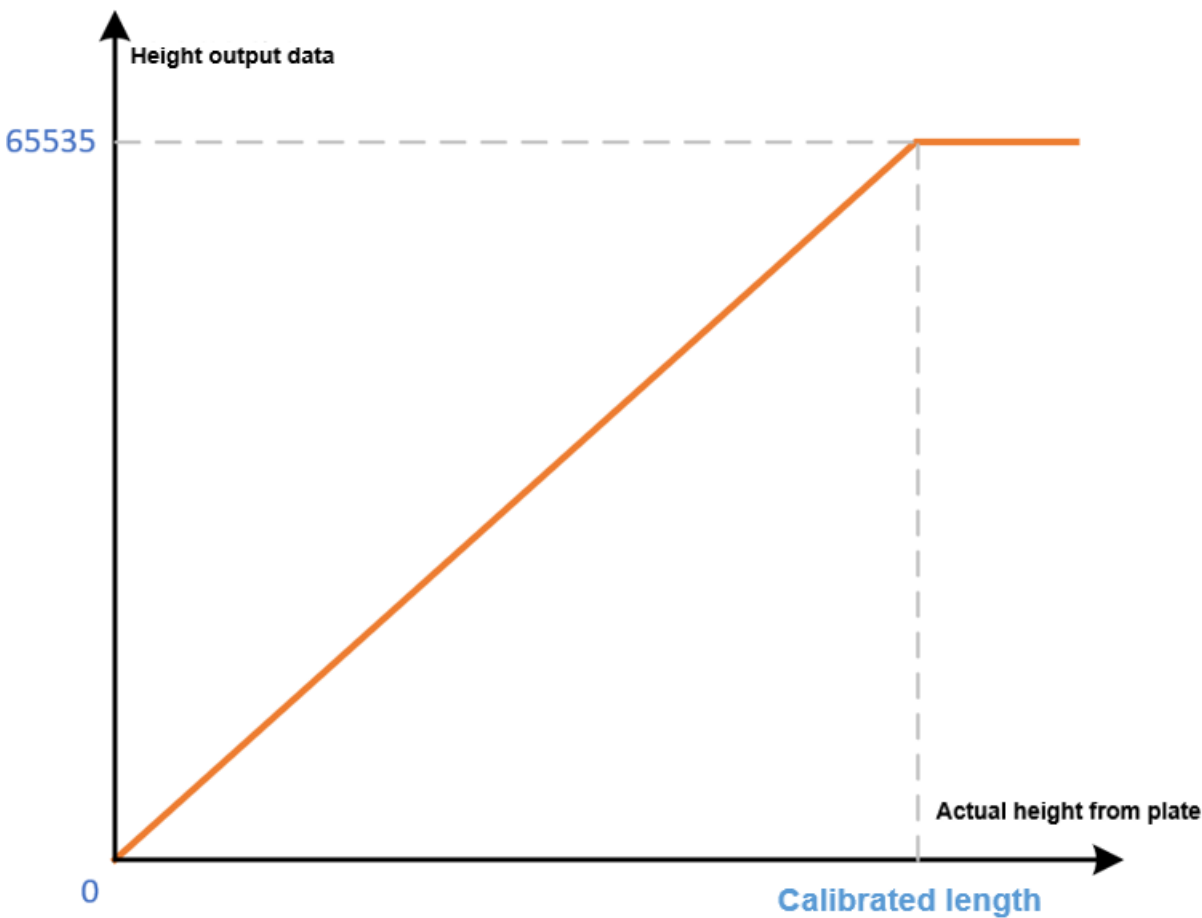

## Associated Parameter

- [Nozzle Loss Alarm Threshold \(Tolerant LozzLost\)](#)
- [Collision Threshold \(TT LEVEL\)](#)
- [Collision Delay \(ColDelay\)](#)
- [Nozzle Loss Detection Switch \(LozzLost\)](#)
- [Height Output Filter Time \(Fi\\_UPLAS\)](#)

## Auxiliary Function

## Parameter Reading and Writing

For core parameters related to functions in VT310E, please refer to [Parameter Description](#). Parameters can be read and written via index access in the EtherCAT object dictionary.

### CAUTION

- The setting parameters cannot exceed the allowed parameter range, otherwise the setting will be invalid.
- Parameter settings take effect immediately after completion.
- If you want to save this setting value to the machine, you need to operate PDO (save); otherwise, after power failure and restart, the parameters will be restored to the last saved value.

## Firmware Update

VT310E can connect to a host equipped with debugging software iFollow through the USB communication interface to perform firmware update.

### Operation Step:

1. Connect the device through iFollow and read the device name *VT310E*.
2. Click the firmware update button, select the bin file with the prefix *VT310E-FPGA*, and click open to update the firmware.
3. The update process will display the update progress, and when the update is completed, a pop-up window will prompt that the update is successful.
4. After restarting the VT310E device, it starts running normally.

# Parameter Description

The function related parameters of VT310E are as follows:

PARAMETER	SDO NAME	SET RANGE	DEFAULT VALUE	ACCURACY	UNIT
Calibrated length	Meas_mm	5~25	20	1	mm
Capacitance sampling allowable error	Tolerant CapErr	5~60000	1000	-	-
Nozzle loss alarm threshold	Tolerant LozzLost	10~60000	2000	-	-
Height output filter time	Fi_UPLAS	1~50	6	1	ms
Collision threshold	TT LEVEL	0~100	10	1	0.01mm
Collision delay	ColDelay	0~1020	50	1	ms
Nozzle loss detection switch	LozzLost	0~1	1	-	-
Calibration position delta value detection switch	Delta	0~1	1	-	-

## Calibrated Length (Meas\_mm)

Calibration length for capacitance calibration. The parameter will take effect after setting. Before performing capacitance calibration, you should first ensure that the set calibration length corresponds to the 16-point capacitance calibration to be performed.

## Capacitance Sampling Allowable Error (Tolerant CapErr)

It will take effect after setting the parameters. In order to ensure the accuracy of capacitance calibration, it is required that the capacitance is stable during 100ms capacitance sampling at each reference point when performing 16-point calibration.

- If the capacitance fluctuation exceeds this parameter value during capacitance sampling at the reference point, the calibration will be interrupted (failed).
- If there is large electromagnetic interference on site causing large fluctuations in the capacitance signal, it may be necessary to increase this value appropriately.

## Nozzle Loss Alarm Threshold (Tolerant LozzLost)

It will take effect after the parameter is set. This parameter can reduce the nozzle loss error alarm. When the detected capacitance value is greater than the nozzle loss point capacitance collected during calibration and exceeds this threshold, the nozzle loss alarm will be triggered.

## Height Output Filter Time (Fi\_UPLAS)

It will take effect after the parameter is set. In order to reduce the fluctuation effect of plasma or splash on the capacitance during laser emission, a mean filter is added. VT310E will output the height data that has passed the mean filter, so very short interference peak will be suppressed. This parameter is the filtering time of the mean filter.

## Collision Threshold (TT LEVEL)

It will take effect after setting the parameters. Use the collision threshold parameter to set the height from part when the TIP TOUCH state occurs.

- If the detected current height is less than this parameter, the TIP TOUCH state will be generated.
- If the detected current height is greater than this parameter, the TIP TOUCH state will be cancelled.

## Collision Delay (ColDelay)

It will take effect after setting the parameters. Use the collision delay parameter to suppress the generation of the TIP TOUCH state. Mainly to solve the problem of false triggering of TIP TOUCH state due to interference from plasma or splash.

- Only when the actual collision time exceeds the time of this parameter, the TIP TOUCH status will be actually output.
- After the TIP TOUCH state is cancelled, the output of the TIP TOUCH state is turned off immediately.

## Nozzle Loss Detection Switch (LozzLost)

It will take effect after the parameter is set. Use the nozzle loss detection function to check whether the copper nozzle motor or ceramic ring part exists. When turning on this function, it should be ensured that the distance between the cutting head and the workpiece must be as large as possible when calibrating the nozzle loss point.

## Calibration Position delta Value Detection Switch (Delta)

It will take effect after the parameter is set. In order to ensure a stable relationship between capacitance and distance during the calibration process, the minimum difference in capacitance between different reference points is set under normal circumstances. If the minimum difference in capacitance between reference points cannot be met due to cutting head shape and other reasons. This detection switch can be turned off.



# Object Dictionary

## Input (Read-only)

### Index 0x1A00 Real-time Signal (PDO)

SUB-INDEX		NAME	DESCRIPTION	DATA TYPE
0x3000	0x01	DAC	Height data output, range: 0~65535	UINT32
	0x02	RTCap	Current real-time capacitance value	UINT32
	0x03	FAR	Out of calibration range signal	BIT
	0x04	COLLISION	Touch part signal, nozzle loss auxiliary prompt signal	BIT
	0x05	READY	System running status signal	BIT
	0x06	POS_REACHED	Calibration time data collection signal	BIT

#### NOTE

- FAR: When the measurement range exceeds the calibration range is 1.
- COLLISION: When appear touch part is 1. It can also be used in conjunction with POS\_REACHED to indicate nozzle loss.
- READY: When normal operation is 1, output 0 during system initialization, partial alarm and calibration.
- POS\_REACHED: Calibration response signal of VT310E during capacitor calibration. After receiving STROBE, it will detect whether the capacitor is stable within 100ms. If it is stable, a response signal will be output. If it is still unstable after more than 1s, exit the calibration mode. During the detection process, STROBE is required to remain 1, and can also be used in conjunction with COLLISION to indicate nozzle loss.

### Index 0x1A01 Real-time Status Display (PDO)

SUB-INDEX		NAME	DESCRIPTION	DATA TYPE
0x3001	0x01	CAP_DIFF	Capacitance fluctuation value	UINT8

#### NOTE

CAP\_DIFF: Collect the difference between the maximum and minimum capacitance values within 100ms.

### Index 0x3100 Calibration Data and Status Information (SDO)

SUB-INDEX	NAME	DESCRIPTION	DATA TYPE
0x01	CAP_16		
0x02	CAP_15		
0x03	CAP_14		

SUB-INDEX	NAME	DESCRIPTION	DATA TYPE		
0x04	CAP_13	Capacitance values corresponding to 16 calibration points	UINT32		
0x05	CAP_12				
0x06	CAP_11				
0x07	CAP_10				
0x08	CAP_9				
0x09	CAP_8				
0x0A	CAP_7				
0x0B	CAP_6				
0x0C	CAP_5				
0x0D	CAP_4				
0x0E	CAP_3				
0x0F	CAP_2				
0x10	CAP_1				
0x11	CAP_NL			Nozzle loss point calibration value	UINT32
0x12	CurState			Current status value 1.Not ready 2.Measurement mode 3.Calibration mode 4.Debugging mode 5.Error	UINT8

**NOTE**

- CAP\_16 ~ CAP\_1: Capacitance values corresponding to 16 calibration points.
- CAP\_NL: The capacitance value of the nozzle loss point calibration.

## Output (Readable and Writable)

### Index 0x1600 Calibration Signal (PDO)

SUB-INDEX		NAME	DESCRIPTION	DATA TYPE
0x2000	0x01	CAL_REQUEST	Calibration start signal	BIT
	0x02	STROBE	CNC control in position signal	BIT
	0x03	NL_STROBE	Body capacitance calibration signal	BIT

#### **NOTE**

- CAL\_REQUEST: Calibration start signal, 1 indicates the request enters the calibration state, 0 indicates the request exits the calibration state.
- STROBE: During the capacitance calibration process, the signal is received after the axis is in position.
- NL\_STROBE: When in the NORMAL state, the READY signal is set low when the port is high level, and the current capacitance value is recorded at the same time, and the current capacitance value is used as the body capacitance value.

### Index 0x2100 User Parameter (SDO)

SUB-INDEX	NAME	DESCRIPTION	DATA	DEFAULT VALUE	MINIMUM VALUE	MAXIMUM VALUE	UNIT
0x01	Meas_mm	Calibrated length	UINT8	20	5	25	mm
0x02	Tolerant CapErr	Capacitance sampling allowable error	UINT16	1000	5	60000	-
0x03	Tolerant LozzLost	Nozzle loss alarm threshold	UINT16	2000	10	60000	-
0x04	Fi_UPLAS	Height output filter time	UINT8	6	1	50	ms
0x05	TT LEVEL	Collision threshold	UINT8	10	0	100	0.01mm
0x06	ColDelay	Touch part delay	UINT16	50	0	1020	ms
0x07	LozzLost	Nozzle loss detection switch	BIT	1	0	1	-
0x08	Delta	Calibration position delta value detection switch	BIT	1	0	1	-
0x09	Save	Save parameters to Flash	BIT	-	-	-	-
0x0A	Restore	Restore default parameter	BIT	-	-	-	-
0x0B	Restart	Soft restart	BIT	-	-	-	-

#### **NOTE**

SAVE: Used to save parameters. The parameters of VT310E will take effect after setting, but the parameters will be reset after power failure. Each time SAVE is set from 0 to 1, the parameters will be saved once.